

Commentationes Humanarum Litterarum
136 2019

DOMUS POMPEIANA
M. LUCRETII IX 3, 5.24

The Inscriptions, Works of Art and Finds
from the Old and New Excavations



Edited by Ria Berg & Ilkka Kuivalainen



Societas Scientiarum Fennica
The Finnish Society of Sciences and Letters

SSF Comment. Hum. Litt. 136. 2019. Domus Pompeiana M. Lucretii IX 3, 5.24



ISBN 978-951-653-433-9
ISSN 0069-6587

DOMUS POMPEIANA
M. LUCRETII IX 3, 5.24

The Inscriptions, Works of Art and Finds
from the Old and New Excavations

Societas Scientiarum Fennica

The Finnish Society of Sciences and Letters

Address: Pohjoinen Makasiinikatu 7 A 6, FI-00130 Helsinki

In Swedish: Finska Vetenskaps-Societeten, Norra Magasinsgatan 7 A 6, FI-00130 Helsingfors

In Finnish: Suomen Tiedeseura, Pohjoinen Makasiinikatu 7 A 6, FI-00130 Helsinki

Commentationes Humanarum Litterarum

The series, founded in 1923, publishes monographs and other studies on antiquity and its tradition.

Editor: Prof. Mika Kajava

Address: Department of Languages, P.O. Box 24, FI-00014 University of Helsinki.

Requests for Exchange:

Exchange Center for Scientific Literature, Snellmaninkatu 13, FI-00170 Helsinki, or at the Secretary of the Society.

Distributed by:

Tiedekirja, Snellmaninkatu 13, FI-00170 Helsinki; tiedekirja@tsv.fi, www.tsv.fi

Other series published by the Society:

Commentationes Physico-Mathematicae

Commentationes Scientiarum Socialium

Bidrag till kännedom av Finlands natur och folk

The History of Learning and Science in Finland 1828–1918

Årsbok – Vuosikirja (Yearbook), serie A sarja

Sphinx (Årsbok – Vuosikirja, serie B sarja)

Commentationes Humanarum Litterarum
136 2019

DOMUS POMPEIANA
M. LUCRETII IX 3, 5.24

The Inscriptions, Works of Art and Finds
from the Old and New Excavations

Edited by Ria Berg & Ilkka Kuivalainen

Societas Scientiarum Fennica

The Finnish Society of Sciences and Letters

Commentationes Humanarum Litterarum
is part of the publishing cooperation between
the Finnish Society of Sciences and Letters and
the Finnish Academy of Science and Letters



ISSN 0069-6587
ISBN 978-951-653-433-9

ISSN 2736-9374 (PDF)
ISBN 978-951-653-476-6 (PDF)

Copyright © 2019 by
Societas Scientiarum Fennica

Layout by Maija Holappa

Printed by Hämeen Kirjapaino Oy, Vantaa 2019

Front cover: Watercolour by Edward Falkener in

Contents

PREFACE	7
PAAVO CASTRÉN	
INTRODUCTION TO THE PROJECT	10
RIA BERG	
LE ISCRIZIONI PARIETALI	
Abitanti e visitatori	16
PAAVO CASTRÉN	
Schede epigrafiche	24
ANTONIO VARONE	
FINDS FROM THE 1847 EXCAVATIONS	
Documentation History	45
RIA BERG	
Distribution Patterns	54
RIA BERG	
I Works of Art	
I.1 Marble Sculpture	68
ILKKA KUIVALAINEN	
I.2 Minor Arts of Terracotta	117
LEENA PIETILÄ-CASTRÉN	
II Vessels	133
RIA BERG	
II.1 Bronze	136
II.2 Glass	146
II.3 Terracotta	157

III Instruments and Utensils	161
RIA BERG	
III.1 Lighting	161
III.2 Medical and Cosmetic Instruments	168
III.3 Iron Tools	177
III.4 Adornment and Valuables	182
IV Fixtures	187
RIA BERG	
IV.1 Closure elements	187
IV.2 Other Fixtures and Furniture	191
IV.3 The Chariot	193
V Architectural Elements	195
RIA BERG	
NEW FINDS FROM THE 2001–2010 EXCAVATION CAMPAIGNS	
VI Wall Plaster Fragments	196
VILLE HAKANEN	
VII Masks	222
LEENA PIETILÄ-CASTRÉN	
CONCLUSIONS	225
Appendix 1: Catalogue of Finds from the Excavations of 1847 by Room	228
RIA BERG	
Appendix 2: Synthesis of Floors and Wall paintings	292
ILKKA KUIVALAINEN, KIRSI MURROS & ANTERO TAMMISTO	
Appendix 3: Plan of the House of Marcus Lucretius IX 3, 5.24	302
Illustration Credits	303
Bibliography	306
Participants and Associates of the EPUH Project	324

Preface

PAAVO CASTRÉN

Finland has a long tradition in Pompeian studies, beginning in the early 1930's when Dr. Veikko Väänänen, subsequently Professor of Romance languages at the University of Helsinki, spent several years in Naples and Pompeii and became acquainted with many local archaeologists and philologists. He developed particularly close contacts with Matteo della Corte, who at that time was preparing a Supplement to the *Corpus Inscriptionum Latinarum* IV, which contains the Pompeian graffiti and election *programmata*. Mostly on the basis of this collection of graffiti, Väänänen was able to reconstruct several aspects of the language spoken in Pompeii before the great eruption of Vesuvius. He discovered that many linguistic phenomena that had been considered to belong only to the later development of Romance languages had already appeared before AD 79. His academic dissertation, *La langue vulgaire des inscriptions Pompéiennes*, was published in 1935. Due to his mastery of vulgar Latin and the longstanding contacts he had made, Professor Väänänen became well known not only within the community of Pompeian studies but also in the broader academic world.

Finland's first institute abroad, the *Institutum Romanum Finlandiae*, was established in 1954 in the stately Villa Lante on the Gianicolo Hill in Rome. In the early period, Latin epigraphy and onomastics were the main fields of scholarship at the institute. When Väänänen became Director of the Institute in 1959, he invited eleven graduate students, mostly of classical philology, to come to Rome from Finland to participate in a course in Latin epigraphy. A lengthy visit to Pompeii, Herculaneum, and Stabiae was organized as part of this course, and some of the participants went on to write papers on Pompeian material. In this way the tradition of Pompeian studies in Finland was continued, and the future professors Heikki Solin and myself, the second generation of Pompeian scholars, were amongst those that participated in this course.

Heikki Solin is now in the final phases of preparing a new edition of the *Corpus Inscriptionum Latinarum* X, which includes the Pompeian monumental inscriptions, and has written numerous articles on the parietal inscriptions of Pompeii, as well as a study on the municipal life of Herculaneum. For my part, in 1975 I wrote my academic dissertation on a Pompeian topic, *Ordo Populusque Pompeianus. Polity and Society in Roman Pompeii*. In this work, the names of all known Pompeians from the period of 87 BC–79 AD were collected, and the political and economic role played by various families in different periods were studied.

Through this work, we had in turn prepared the road for the third generation of Finnish Pompeian scholars, including Liisa Savunen and Antero Tammisto. Liisa Savunen wrote her academic dissertation on the political, economic, and religious roles played by

women in Pompeii, and Tammisto on *Birds in Mosaics*. Both scholars became well known in Pompeian circles and went on to support younger students in starting their own studies in Pompeii.

In the mid-1990's an international meeting was held in Ravello wherein it was agreed that study and excavation permits should be granted more freely



The fountain of the House of M. Lucretius, ca. 1962. Photo by Helen Väänänen, the American wife of Veikko Väänänen. (University of Helsinki.)

to foreign institutions, on the condition that they take responsibility for entire quarters, and not only for the better known individual houses. It was also recommended that the efforts be mainly concentrated upon studying the areas excavated in the 18th and 19th centuries but never adequately published. When an exhibition of jewellery from Pompeii and Herculaneum was organized at the Sinebrychoff Art Museum in Helsinki in 1998, the Italian colleagues responsible for the exhibition warmly reminded us of the old traditions of cooperation and research. At this instigation, in 2000 a preparatory project was established and in 2001 an international series of seminars on Pompeii was arranged in Helsinki, in which the then Director of the Excavations of Pompeii Dr. Antonio Varone, participated. He suggested that Finland take up the study of *insula IX 3* which lies almost in the geographical centre of the town near the Central Baths. The *insula* comprises approximately 3500 m² of structures, and includes the well-known patrician House of Marcus Lucretius.

Rector Kari Raivio and his successor Ilkka Niiniluoto recommended that the University of Helsinki grant financing for the first Finnish survey project in Pompeii in 2002, and applied to the Superintendency of Pompeii for an excavation permit, which was promptly granted by Professor Pietro Giovanni Guzzo. The project was called the *Expeditio Pompeiana Universitatis Helsingiensis* (EPUH) to express our gratitude towards the University. Subsequently, the Academy of Finland awarded the project a grant that enabled the work from 2004 to 2006. Later grants from the Finnish Cultural Foundation, the Emil Aaltonen Foundation, and the Ella and Georg Ehrnrooth Foundation enabled us to carry out additional field work and further research into the archaeological storerooms and archives in Pompeii and Naples. We express our sincere thanks to all of these institutions. The team consisted of archaeologists, classical philologists, art historians, architects, and photographers. In 2004, the Design Institute of the EVTEK University of Applied Sciences

joined the project. We thank them for several studies on the colour pigments of the wall paintings, recovered from fresco fragments buried in the garden and under the atrium of the House of Marcus Lucretius, and for preparing a three-dimensional model of the house and its surroundings.

In the spring 2008, the project organized the exhibition *Domus Pompeiana. A House in Pompeii* at the Amos Anderson Art Museum in Helsinki. EPUH was responsible for the text and direction of the exhibition drama, whereas EVTEK was responsible for its physical setting and context. The exhibition was very well received by the public, and attracted many younger visitors.

After this exhibition, it was time for the next generation of Finnish Pompeian scholars to take the helm, and Antero Tammisto took over direction of the project. The scientific devotion of the fourth generation of Pompeianists is manifest in many ways, and several academic theses on Pompeian and related materials have been presented by the team members. Of the editors of the present volume, Ria Berg wrote her PhD thesis on the role of female toiletry objects in AD 79 house-floor contexts, and, more widely, on the principles of Roman domestic storage, and Ilkka Kuivalainen is completing his extensive dissertation on Bacchic iconography in Pompeii, starting from the seminal figures of the House of Marcus Lucretius. Many others have also contributed to this continuing tradition, including both established and emergent scholars, among whom are: Sanna Aho, James Andrews, Gianluca De Martino, Zbigniew Fiema, Marttiina Fränti-Pitkäranta, Ville Hakanen, Nina Heiska, Maija Holappa, Kai Juntunen, Anu Koponen, Lotta Laiho Oliviero, Kirsi Murros, Laura Nissin, Samuli Simelius, Tiina Tuukkanen, Katja Varakas, Eeva-Maria Viitanen, and Heini Ynnilä.

We thank, in particular, the Naples Archaeological Museum, Superintendency of Pompeii, and the *Institutum Romanum Finlandiae* for their cooperation and assistance during this research work. Special thanks are due to Maija Holappa for the layout, and Dr. Christopher TenWolde for revision of the English language. Our thanks are also due to Dr. Hilary Cool and Dr. Antero Tammisto for their support of our publication, and we also thank the anonymous revisors, and Prof. Mika Kajava for accepting the volume to be published in the series of *Commentationes Humanarum Litterarum*. This project has played a unique role in the Finnish tradition of Pompeian studies. It is our hope that its successful combination of the patient study of older finds – many of which were thought to be lost – alongside the meticulous archival research carried out by Ria Berg, will inspire both current and future research teams to continue their work and publish in a timely manner.

Finally, I thank our Italian colleagues for their inspiring discussions and constant support during our time in Pompeii, and my former team members for their friendship and devotion. I do hope that the tradition of Finnish classical scholarship at Pompeii will continue well into the future.

Helsinki, August 2019
Paavo Castrén

Introduction to the Project

RIA BERG

The Pompeii Project of the University of Helsinki (*Expeditio Pompeiana Universitatis Helsingiensis*, EPUH), first directed by Paavo Castrén (2002–2009) and then by Antero Tammisto (2009–), has as its goal the documentation, analysis, and publishing of all the structural and material remains, wall paintings, and finds of a single Pompeian city block, Insula IX 3. This volume is dedicated to the exceptionally rich finds of its largest unit, the House of Marcus Lucretius (IX 3, 5.24).

The house was originally excavated in 1847, and the remaining parts of the *insula* were completely unearthed by 1871. The excavators of the house first gave it the name *Casa delle Suonatrici*, on the basis of a fresco painting in the *fauces*, but it was soon renamed *Casa di Marco Lucrezio* when a small painting displaying writing equipment and featuring a letter scroll addressed to *M. Lucretius, flamen Martis*, the probable owner of the house in its last phase of occupation, was found in room 20.¹ The city block is situated along the most central N-S street of the town, the Via Stabiana, and covers an area of ca. 3500 m². It has a roughly equilateral, quadrangular form (ca. 54 x 64 m). In its AD 79 phase, the *insula* had at least 18 independent units with more than 150 rooms and 25 doors opening onto the streets around it. Furthermore, in the NE corner of the *insula* there was an unbuilt plot which could have accommodated 2–3 more houses, which were probably destroyed in the AD 62 earthquake and never built again. The House of Marcus Lucretius, the largest structure of the *insula* (555 m²), was also by far the most richly decorated and furnished; and, as evinced by its rich finds, including more than 500 individual items, it was undoubtedly inhabited at the moment of the eruption.

The University of Helsinki team started working on the site in 2002, through the generous permission of the Soprintendenza Archeologica di Pompei as represented by superintendent Pietro Giovanni Guzzo. The work proceeded in three main phases: the first phase, including the excavation and field documentation of the structures and paintings, was completed in 2002–2006. The second phase saw the preparation of a large exhibition entirely dedicated to the House of Marcus Lucretius, inaugurated in Helsinki in 2008. In the third phase, during 2009–2012, some additional fieldwork was carried out and the preparations for the final publication was begun, by processing the recovered material, analysing the ensuing data, and conducting archival research. The project received its initial funding from the University of Helsinki in 2002. The Academy of Finland then awarded the project a grant that enabled the work from 2004 to 2007. Another grant from the Finnish Cultural Foundation was used to start the additional field work in 2009,

¹ See Castrén 2008, 27, with fig. 3.1 on p. 26.

and this work was continued to its end in 2012 through funding from the Emil Aaltonen Foundation.² Preliminary overviews of the work have been published in two articles in the series *Nuove ricerche a Pompei*, and the year-by-year reports can be consulted in the *Fasti on-line* web pages.³

A very important intermediate goal of the project was the creation, in collaboration with the Archaeological Museum of Naples, of an exhibition on the House of Marcus Lucretius in the central Amos Anderson Museum in Helsinki, open from March 1 to May 25, 2008. Included in the framework of the exhibition, an accompanying book discussing the house with its building history, architectonic forms, decoration and furnishings, and also the goals and methods of the project, was published in Finnish, Swedish, and Italian.⁴ The exhibition brought to Helsinki, *in primis*, seven central wall paintings of the house, including the large-scale image of Hercules and Omphale that had decorated its main triclinium 16. In fact, the most important paintings of the house had been cut out and taken to the Archaeological Museum in Naples already in the 19th century.⁵ In the central exhibition space the most representative and lavishly decorated room of the house, the triclinium R16, was entirely reproduced at 1:1 scale, even fitting the extracted paintings into walls that were painted according to the original scheme.⁶ In addition, the small garden space R18 was recreated, complete with a replica of its mosaic fountain niche, and including seventeen original marble sculptures and four marble oscilla plates.⁷ Also displayed in the exhibition were a group of eight plastic terracotta figurines.⁸ Other items belonging to the AD 79 furnishings included ten bronze artefacts, four glass objects, a golden ring, and a terracotta money-box.⁹ Furthermore, a wide selection of the new finds from the stratigraphic excavations (coins, lamps, terracotta, glass, bone and metal fragments) were displayed.¹⁰

The overall work of the project has been organized in specialized teams, which will produce independent volumes for the final publication: the documentation and analysis of the wall paintings (Antero Tammisto and Ilkka Kuivalainen), an account of the new excavations and architectural structures (Eeva-Maria Viitanen), finds processing (Ria Berg), and geodetic measuring and the production of new cartography and 3D modelling (Nina Heiska and Maija Holappa).

The volume by the wall-painting team will include, first and foremost, the complete documentation of the wall-paintings, pavements, and other decorative features of the in-

² Funding institutions of the EPUH research: University of Helsinki (2002–04, 2007), Finnish Cultural Foundation (2002–04, 2008, 2013–2016), Ella and Georg Ehrnrooth Foundation (2003), Engel Corporation (2003), Academy of Finland (2004–07), Emil Aaltonen Foundation (2010–12).

³ Castrén – Fiema – Viitanen 2005; Castrén – Berg – Tammisto – E.-M. Viitanen 2008; *Fasti on-line* http://www.fastion-line.org/micro_view.php?fst_cd=AIAC_2461&curcol=main_column

⁴ *Domus Pompeiana*.

⁵ Tammisto – Kuivalainen 2008; Berg et al. 2008, 205.

⁶ Räsänen – Wassholm 2008.

⁷ Kuivalainen 2008; Berg et al. 2008, 205–207.

⁸ Pietilä-Castrén 2008; Berg et al. 2008, 207.

⁹ Berg 2008a; Berg et al. 2008, 207–208.

¹⁰ Berg 2008b; Berg et al. 2008, 209–211.

sula, in their present condition, achieved through photography, drawings, and the help of scaled ortho images, detailed drawings on transparent foil, and verbal descriptions. The documentation of the detached central panels has been carried out in the Naples Museum. In addition, all previous data from archives and publications concerning the paintings of the house has been collected, also including old pictures, drawings, water colours, and photographs, in order to understand and reconstruct the original pictorial programme, which is now severely deteriorated.¹¹ Collaboration with the conservators and conservator students of the Metropolia University of Applied Sciences (formerly EVTEK Institute of Art and Design) have produced analyses of the colour pigments used in the wall paintings.¹²

Another independent volume will be dedicated to the documentation and analysis of all standing architectonic structures, as well as those brought to light by select stratigraphic excavation. A large part of the work has consisted of the room-by-room and wall-by-wall documentation and structural archaeological analysis, carried out through verbal description, drawing, and photography, in order to understand better the earlier phases and development of the insula, as well as its articulation in AD 79. The fundamental aspects of this work have been carried out by the measuring team, which has produced a new, more accurate ground plan of the insula and, additionally, sounded out its underlying ground formation – a small hillock – with a total station during the campaigns of 2002–2006. Sections cutting through the whole insula have also been produced, and students from EVTEK have collaborated in the creation of three-dimensional graphic models of the House of Marcus Lucretius. Furthermore, in 2006, the House of Marcus Lucretius was documented by means of a laser scanner.¹³

To discover and understand the earlier phases of the insula, small-scale archaeological excavations – all in all 12 trenches – were conducted below the AD 79 floor levels, mainly in the House of Marcus Lucretius but also in the surrounding streets and houses.¹⁴ The first two trenches were dug in 2003 in the atrium (R2) and the corridor (R17). The work was continued in 2004 in the kitchen area (R12 and R14), where the toilet fill proved to be one of the richest find contexts of the house, and with two trenches in the garden (R18). The garden trenches revealed evidence for the occupation of the site already in the 6th century BC, through a *pappamonte* tufa wall dated by fragments of bucchero and Attic black figure pottery.¹⁵ In 2005, the garden trenches, which had also hit large waste pits, were continued and extended, and new trenches were excavated in three areas of the adjoining House IX 3,24 (R26–27, R29, and R31). During the last excavation year, in 2006, two trenches were dug in the alley north of the insula, and one in as well as in House IX 3, 25.¹⁶ Excavations

¹¹ Tammisto – Kuivalainen 2008.

¹² Knuutinen – Mannerheimo 2008.

¹³ Heiska 2008; Kaarto 2008.

¹⁴ Viitanen – Andrews 2008.

¹⁵ Castrén – Berg – Tammisto – Viitanen 2008, 332–333, fig. 4–5.

¹⁶ Castrén – Berg – Tammisto – Viitanen 2008, 332, fig. 1.



Plan of Insula IX 3, with the House of M. Lucretius and the excavation trenches in grey.

in the alley in front of the *opus quadratum* façade of House IX 3, 24, which was attached as part of the House of Marcus Lucretius, have dated the structural planning of the insula to the end of the 4th or the beginning of the 3rd century. The joining of the two houses could not be precisely dated through excavation, but they seem to have been united at least since the beginning of the 1st century AD. Under the atrium R2, excavation revealed traces of an older cistern, connected to an earlier impluvium.¹⁷ The large-scale rebuilding of the house may most plausibly be connected with the extensive damage suffered by the insula during the AD 62 earthquake. This was confirmed by the finding of numerous waste pits

¹⁷ Castrén – Berg – Tammisto – Viitanen 2008, 334, fig. 6.

containing building debris, including several hundred fresco fragments mostly in the I and II Pompeian style, under the atrium and garden surfaces.¹⁸ In its last phase, the house was completed with a second floor and richly decorated in IV style.

The major part of the new finds from these stratigraphic excavations and the other old finds of the insula will be published in the forthcoming volume dedicated to the structural documentation and analysis, and the overall results of the excavations. In the present volume, of the new finds only two categories of specific interest have been included. These are the terracotta masks, studied by Leena Pietilä-Castrén, and the group of fresco fragments from the waste pit under the garden (R18), studied by Ville Hakanen.

The present volume, the first of the publication series, concentrates on evidence concerning the household of Marcus Lucretius and its activities in AD 79. The volume starts with a presentation of its wall inscriptions, compiled by Paavo Castrén and Antonio Varone, an archaeologist of the Superintendency of Pompeii who has worked closely with the project since its beginning, and who is now working on the new Supplement to volume IV of the *Corpus Inscriptionum Latinarum*. The rest of the book is dedicated to the material finds: the history of their discovery and documentation, their distribution in the domestic space of the house, their division into functional groups, and their meanings as parameters of the wealth and status of the household. A general overview of these aspects can be found in the chapter Documentation History and Distribution Patterns, in which the principles of the classification of the artefacts into functional categories are discussed. In the following chapters, the objects are presented according to these categories, each including the complete catalogue entries of the objects that have been located in the storerooms of the Naples Museum and Pompeii for study. Even though it has been possible to locate, study, and catalogue only about 12% of the original finds, this volume also contains a systematic analysis of the not-located, lost finds based on inventory records and early publications.

The first category to be presented is that of ‘objets d’art’, with decorative and possibly cult functions, starting with the complete publication and analysis of one of the most famous features of the house, the rich statuary group found in the small peristyle garden, by Ilkka Kuivalainen, in the chapter Marble Sculpture. Most of the garden statues were preserved in the Pompeii archaeological storerooms. Another important ensemble of objects belonging to the category of artwork is the exceptionally large group of terracotta statuettes found in the house, analysed by Leena Pietilä-Castrén under the heading Minor Arts of Terracotta. Then follow the other main categories – Vessels, Instruments & Utensils, Fixtures – discussed by Ria Berg. The vessels, a category difficult to classify by exact and univocal function, are subdivided according to their material: bronze, glass, or terracotta. The chapter Instruments and Utensils is, on the other hand, subdivided according to functional groups: medical instruments, lighting instruments etc. A room-by-room list of all the finds, discussing the find places of the objects, and including all available archival

¹⁸ Castrén – Berg – Tammisto – Viitanen 2008, 336; Hakanen in this volume.

and inventorial data can be found in Appendix 1. In Appendix 2, the mythological motifs of the wall painting in each room are listed, providing a tool to set the finds in their architectural context.

The house-floor contexts from the AD 79 eruption layers are among the most unique datasets of the Vesuvian cities, offering precious opportunities to study objects in their use context, in close relation with their architectural and social setting. However, contextual studies on Pompeian finds are not numerous. Pompeian artefacts have primarily been published very selectively in thematic exhibition catalogues, and in catalogues of specific object types that give little importance to the contextual proveniences of the objects. These studies, in fact, mostly concentrate on the objects as produced items, rather than consumed items.¹⁹ Contextual publications of Pompeian finds in their eruption layers, by house and by insula, which would be so crucial for our understanding of the identity and lifestyles of the ancient city, still largely remain *desiderata*.²⁰ Suzanne Tassinari's *Il vasellame bronzeo da Pompei* and Lucia Scatozza Hörich's *L'instrumentum vitreum da Pompei* are important milestones in the publication of Pompeian finds, as they also provide the contextual information for the objects in addition to their typological presentation.²¹ Exemplary forerunners for the present book, which focus entirely on finds in context, are Joan Berry's studies on the finds of the insulae I 7, I 8, and I 9,²² Penelope Allison's study of the finds of the insula of Menander, I 10,²³ Bernhard Sigges' studies on the finds of the houses published in the series *Häuser in Pompeji*,²⁴ and, more recently, Hilary Cool's publication of the finds from the recent excavations in insula VI.1²⁵ and the publication of both old and new finds from the House of the Centenary, coordinated by Antonella Coralini.²⁶

The insula and House of Marcus Lucretius differ from the above-mentioned studies on Pompeian finds by the earlier date of their excavation. This means that more emphasis had to be placed on archival sources and their interpretation, as the major part of the finds can no longer be located to be physically studied. On Vesuvian sites that had a long history of excavation, the importance of old inventory records can hardly be overestimated, and they often give surprisingly accurate and meticulous descriptions of otherwise lost objects. Of central importance for their use is the precise understanding of the terminology in use during the various periods they were written.

The present book, with its holistic approach to Pompeian finds in their lived context, emphasizes the long post-excavation history of the objects, and ultimately hopes to represent one further step towards the important goal of a more comprehensive publication of Pompeian AD 79 house-floor contexts.

¹⁹ Allison 2008, 4–5 *et passim*.

²⁰ Cool 2016, 277 *et passim*.

²¹ Tassinari 1996; Scatozza 2012.

²² Berry 1997c.

²³ Allison 2008.

²⁴ Sigges 2002.

²⁵ Cool 2016.

²⁶ Coralini 2018.

LE ISCRIZIONI PARIETALI

Abitanti e visitatori

PAAVO CASTRÉN

Introduzione

Le iscrizioni parietali della casa di Marco Lucrezio comprendono alcune poche iscrizioni dipinte, diverse iscrizioni graffite, nonché alcune firme moderne di visitatori ottocenteschi che presentano un certo interesse. Per quanto concerne le iscrizioni dipinte si annoverano cinque manifesti elettorali rinvenuti sulla facciata della casa lungo la via Stabiana, ora andati perduti, nonché un preziosissimo quadretto raffigurante una lettera inviata a un Marco Lucrezio, ora conservato al Museo di Napoli, trovato in un ambiente di passaggio (amb. 20) tra la parte anteriore della casa e quella posteriore. Dei 23 graffiti, invece, la maggior parte, 13, si rinvengono nell'ambulacro di passaggio tra la parte anteriore della casa e quella posteriore (pluteo settentrionale e pilastro NE del giardino 18 (amb. 19) e setto di parete tra gli ambienti 20 e 27), due nell'amb. 26, 4 nelle fauces (amb. 1), 1 nell'amb. 5 e 3 nell'amb. 7. L'ampia frequenza di iscrizioni graffite in ambienti di passaggio è un dato facilmente confrontabile con quello di altre case pompeiane. Di tutti questi graffiti ben 14, ossia tutti quelli tramandati dalla letteratura precedente, sono andati irrimediabilmente perduti e di essi si conservano solo disegni o comunque trascrizioni. Dei rimanenti 9, inediti, si dà qui illustrazione. Essi si riferiscono, peraltro, in quattro casi a numerali, mentre in cinque a nomi. Si noti, in particolare, che ben tre casi di numerali si trovano nello stesso ambiente, dove compaiono essi unicamente. Il quarto numerale, invece, si è trovato nelle fauces (amb. 1), dove peraltro sono stati anche trovati tre graffiti riguardanti nomi. Per finire sono state lette anche sette firme ottocentesche, che almeno in un caso ricordano un visitatore illustre della casa.

La ricerca autoptica, la documentazione e lo studio di tali documenti è stata da me effettuata tra il 2002 e il 2003, e un primo parziale resoconto dei risultati è stato da me pubblicato nel 2008 nel volume *Domus Pompeiana*. Dopo il 2008, tuttavia, dopo il mio ritiro dalla direzione del progetto, sono stato impegnato in differenti ambiti di ricerca e non mi è stato più possibile seguire attentamente il prosieguo della letteratura a riguardo della Casa di Marco Lucrezio. Sono quindi stato molto lieto quando l'amico e collega Antonio Varone, che all'inizio del nostro progetto era direttore degli scavi di Pompei, ha accettato di prendersi cura della pubblicazione delle schede dei *tituli picti* e dei graffiti, da lui parallelamente investigati nell'ambito della preparazione dei suoi volumi di *Imagines* e

per l'edizione dell'aggiornamento di *CIL* IV relativo ai nuovi graffiti.¹ Tanto mi permette allora di concentrarmi qui sulle tematiche più salienti emerse dalla lettura di tali iscrizioni a riguardo della casa e dei suoi abitanti, che mi piace evidenziare come singoli episodi di una più vasta storia. Devo peraltro rimarcare che alcuni graffiti da me rilevati all'inizio del nuovo millennio sembrano essere spariti durante gli anni 2007–2018. Ciò, anche se rammarica, non tuttavia sorprende, perché è un dato oggettivo, ampiamente rilevato, che ogni anno una certa percentuale degli intonaci delle case di Pompei sparisce a causa dell'umidità e dei cambiamenti di temperatura.

La pittura parietale con la lettera indirizzata a Marco Lucrezio

La pittura parietale, sul cui contenuto si basa la denominazione della casa (v. *infra*, iscrizione Nr. 6), si trova in una specie di slargo di corridoio, che non appare particolarmente adatto né a soggiorno e nemmeno a spazio di lavoro. Sulla parete sono raffigurati gli strumenti usati per la scrittura (*instrumentum scriptorium*). Ne facevano parte le solite tavolette di legno unite da cerniere e lo stilo, la bottiglietta dell'inchiostro con le penne, e una lettera arrotolata.

La tavola rappresenta quella del *tablinum* della casa dove il padrone riceveva i suoi ospiti e svolgeva il suo lavoro quotidiano. La lettera, però, non è una lettera qualsiasi, ma un ricordo importante, la memoria del quale il padrone della casa voleva serbare e anzi ricordare ai visitatori della sua dimora. Si tratta forse di una lettera di designazione ad un ufficio oppure del conferimento di una carica onoraria.

Sulla lettera è riportato l'indirizzo, che dice: *M(arco) Lucretio flamine Martis, decurioni Pompei(s)*. Se la lettera fosse stata indirizzata a qualche altro posto anziché a Pompei, il destinatario potrebbe essere un qualsiasi Marco Lucrezio. Una lettera indirizzata a Pompei ad un pompeiano, però, è improbabile fosse diretta ad altri che al padrone di casa. Possiamo perciò da ciò concludere che il padrone di casa fosse Marco Lucrezio, sacerdote preposto al culto di Marte e membro dell'*ordo decurionum* di Pompei.

Secondo il testo sulla lettera, Marco Lucrezio era sì un decurione, cioè membro del Consiglio municipale, ma non un vero e proprio magistrato eletto. Benché i membri del Consiglio fossero in genere ex magistrati, per una persona di grandi meriti personali oppure grazie ai meriti della sua famiglia era possibile esservi ammessa già prima dell'elezione ad edile (*aedilis*), la prima delle magistrature municipali. Chi veniva ammesso (*adlectus*) in questo modo era chiamato (*decurio*) *pedarius*, cioè "consigliere nelle ultime file".

Il nostro Marco Lucrezio viene anche denominato *flamen Martis*, cioè il sacerdote responsabile del culto del dio Marte a Pompei. Il dio Marte era per i romani molto più importante del corrispondente dio greco della guerra, Ares, che era piuttosto l'espressione

¹ Varone – Stefani 2009; Varone 2012; *Corpus Inscriptionum Latinarum*, voluminis IV Supplementum. Partis IV fasciculum tertium, in preparazione.

del furore e della violenza cieca, e come divinità poco rispettato. Marte invece faceva parte della primitiva triade suprema di Giove, Marte e Quirino, era considerato il protettore della natura selvaggia, e, come padre di Romolo, giudicato addirittura il progenitore dei romani. A causa del suo ruolo come protettore della natura selvaggia e dell'agricoltura i suoi templi erano di solito situati nella campagna, fuori dalle mura. Ciò spiega il fatto che non si è trovato un suo tempio a Pompei.

La gens Lucretia a Pompei

La famiglia dei Lucretii ebbe notorietà a Pompei a partire dal periodo augusteo. Il primo rappresentante conosciuto di questa famiglia fu Marcus Lucretius Decidianus Rufus, una persona che in origine apparteneva probabilmente alla famiglia indigena dei Decidii che un Lucrezio aveva adottato verso la fine del periodo repubblicano. I Lucretii erano un'antica famiglia romana, originariamente patrizia, che portava il *cognomen* enigmatico Tricipitinus. Più tardi, i Lucrezi plebei si stabilirono nel Lazio e arrivarono in Campania probabilmente all'inizio del II secolo a.C.

Marco Lucrezio Decidiano Rufo aveva servito come *praefectus fabrum*, ossia una specie di aiutante del comandante di una legione durante le guerre del primo secolo a.C.² Divenuto un fermo sostenitore di Augusto venne dall'imperatore premiato con il titolo di *tribunus militum a populo* che lo elevò alla classe dei cavalieri (*ordo equester*).³ È stato ventilato che egli fosse il proprietario dell'imponente villa suburbana, la cosiddetta "Villa di Cicerone", che si trova fuori della Porta di Ercolano. La villa fu portata alla luce nei primissimi scavi settecenteschi, ma dopo venne di nuovo coperta. Alcuni dei più perfetti mosaici che si trovano nel Museo Archeologico Nazionale di Napoli provengono da quella villa. Sappiamo anche che Marco Lucrezio Decidiano Rufo possedeva una grande collezione di sculture, che in origine forse facevano parte del suo bottino di guerra, e che più tardi lasciò con testamento (*legavit*) alla città di Pompei. Ancora durante gli ultimi anni di Pompei, cioè dopo il terremoto del 62 d.C., un discendente della sua famiglia originale, Marco Decidio Pilonio Rufo, restaurò uno dei monumenti costruiti dal suo celebre parente (*CIL X 851*).

Di altri illustri Lucretii pompeiani parleremo in seguito, ma resta il fatto che l'esatta identificazione del nostro Marco Lucrezio, decurione e *flamen Martis*, non è certa perché sulla sua "lettera di designazione" appare senza il *cognomen*. A dire il vero ciò non sorprende perché ancora in epoca giulio-claudia membri delle *élites* municipali potevano alle volte apparire senza il *cognomen*, che sicuramente avevano, anche in circostanze ufficiali.

Per età potrebbe apparire come figlio di M. Lucrezio Epidio Flacco, che senza dubbio era uno dei personaggi di altissimo rilievo del periodo giulio-claudio: svolse infatti il ruolo

² Suolahti 1955, 205–209.

³ Nicolet 1967, 29–76.

di *praefectus iure dicundo* come sostituto del futuro imperatore Caligola, invitato a fare il duoviro onorario a Pompei per l'anno 33/34 d.C. e fu *duovir quinquennalis* per l'anno 40/41, durante il quale condusse il censimento della popolazione di Pompei, apparentemente insieme allo stesso imperatore, che comunque venne assassinato nel gennaio del 41. Ovviamente i decurioni dovettero nominare un sostituto all'imperatore, il nome del quale è però sconosciuto.

Il labirinto

Su un pilastro del giardino che si trova vicino alla pittura di cui sopra, c'era un'altra iscrizione interessante. Sull'intonaco del pilastro era scarabocchiato un labirinto, intorno al quale era scritto: *Labyrinthus. Hic habitat Minotaurus* (Labirinto. Qui abita il Minotauro; v. *infra*, iscrizione Nr. 7). Al labirinto si è voluto dare un significato mistico o apotropaico, e se apparisse senza alcuna ulteriore spiegazione, l'idea potrebbe anche aver valore. Comunque, la didascalia banale ne fa piuttosto il ricordo di una lezione di mitologia. In ogni modo, anche questa iscrizione dimostra che la famiglia di Marco Lucrezio s'interessava di cultura.

I graffiti sotto il labirinto

Al di sotto del disegno del labirinto compaiono alcuni graffiti difficilmente leggibili e per essi faccio rimando a quanto detto *infra* da Varone (iscrizioni Nr. 8–10). Mi preme tuttavia far presente che mi fido poco del disegno lasciatocene da La Volpe, sebbene il suo compito non fosse facile. Probabilmente si tratta di nomi e insulti personali, scarabocchiati da schiavi quasi analfabeti. Ci sono, comunque, un paio di parole interessanti, ad es. LATARIVS o LATTARIVS (iscrizione Nr. 8) che potrebbe essere la forma assimilata di LACTARIUS. Väänänen 1966, 63 cita a riguardo esempi come AVTIONE.. FATA (*auctione facta*, tav. cer. XXVI 27–29), OTAVS (= *Octavus*, CIL IV 4870). Piuttosto che del nome del famoso Mons Lactarius potrebbe comunque trattarsi di uno schiavo addetto alla cura del latte praticata nella vicina *Stabiae*.⁴

L'altro argomento interessante è il fatto che in detti graffiti si incontrano nomi di schiavi di Nerone. IANVARIVS, così, è chiamato sia (*servus*) NERONIS (v. *infra* iscrizione 9) che CINAEDVS (v. *infra* iscrizione 10) e sembra probabile che tale *Ianuarius* sia stato presente tra le persone che avevano scarabocchiato i graffiti o quanto meno sia stato da loro conosciuto. È lecito allora chiedersi che cosa facessero schiavi di Nerone nella casa di Marco Lucrezio.

⁴ Cfr. a riguardo l'interessante lavoro di G. Centonze, *Il Lactarius mons e la cura del latte a Stabiae*. Castellammare di Stabia 2017. Cfr. inoltre Galen. *De methodo medendi* 5,12,13; *Symm. epist.* 6,17; Cassiod. *Var.* 11,10.

Le relazioni dei pompeiani illustri con l'imperatore

A Pompei ci sono stati tre periodi in cui le relazioni fra l'imperatore e il ceto preminente di Pompei si mostrano particolarmente strette. Nell'età augustea gli uomini e le donne più influenti della città si facevano ritrarre in abbigliamenti che imitavano quelli dell'imperatore e dell'imperatrice, e ricoprivano cariche sacerdotali del culto imperiale. L'imperatore elevò i suoi sostenitori più fermi, come ad es. il citato Marco Lucrezio Decidiano Rufo, al rango equestre conferendo loro il titolo onorario di *tribunus militum a populo*.

I Lucrezi furono particolarmente in auge durante il periodo giulio-claudio quando Cn. Lucretius Decens fu edile nel 22/23, M. Lucretius Epidius Flaccus *praefectus iure dicundo* nel 33/34 e *duovir quinquennalis* nel 40/41 insieme allo stesso imperatore Caligola, M. Lucretius Manlianus *duoviro* nel 31/32, e D. Lucretius Valens, che apparteneva ad un altro ramo della *gens* Lucretia, edile nel 33/34.

Anche durante il regno di Claudio (41–54) alcuni cittadini illustri di Pompei vennero nominati a cariche sacerdotali connesse con il culto dell'imperatore: Cn. Alleio Nigidio Maio, che era noto come *princeps coloniae*, cioè il primo cittadino della colonia, divenne *flamen* [Ti. Claudii] *Caesaris Augusti* (CIL IV 1180), e D. Lucrezio Satrio Valente *flamen Neronis Caes(aris) Aug(usti) filii perpetuus* (CIL IV 3884) probabilmente subito dopo l'adozione di Nerone (fra il 50 e il 54). Contemporaneamente si organizzarono a Pompei giochi *pro salute* [Ti. Claudii] *Caesaris Augusti liberorumque*. (Claudio e i suoi figli Claudio Druso, Claudia Antonia, Claudia Ottavia, Britannico e Nerone).

Di M. Lucrezio Epidio Flacco invece non ci sono notizie oltre a quelle del suo incarico come *duovir quinquennalis* del 40/41. Non sappiamo se sia morto subito dopo oppure se la morte dell'imperatore abbia anche influenzato negativamente la sua carriera municipale.

Al tempo di Nerone Pompei entrò nuovamente nelle cronache per un'aspra lite sorta nell'anno 59 tra i nocerini e i pompeiani nell'anfiteatro di Pompei. Molti dei nocerini rimasero uccisi, e l'imperatore e il Senato punirono i colpevoli con l'esilio e con la chiusura dell'anfiteatro per dieci anni. Solo tre anni dopo, nel 62, ci fu il forte terremoto che danneggiò gravemente la città e che fu forse ritenuto una punizione per essa sufficiente.

Proprio nel 62 Nerone aveva intanto sposato Poppaea Sabina, appartenente a una *gens* che aveva grossi interessi economici, oltre a fastose ville d'*otium* nel territorio vesuviano. Nell'anno successivo nacque la figlia Claudia, e l'imperatore attribuì a tutte e due il titolo di *Augusta*. Proprio in questo periodo a Pompei si trovano numerose acclamazioni *pro salute* e in onore di Nerone come *Augustus* e di Poppea come *Augusta* (CIL IV 3822, 1545 con add. p. 208) in alcune delle quali si elogiano particolarmente i loro *iudicia*, cioè giudizi forse a favore dell'eventuale riapertura dell'anfiteatro (CIL IV 1074 con add. p. 199, 3726). Dato che Poppea morì nel 65, queste acclamazioni dovrebbero datarsi fra il 63 e il 65 d.C. Probabilmente Nerone e Poppea visitarono Pompei proprio in quel periodo, promisero di aprire l'anfiteatro, e fecero organizzare giochi in cui molti gladiatori "neroniani" e artisti



Fig. 1.



Fig. 2.

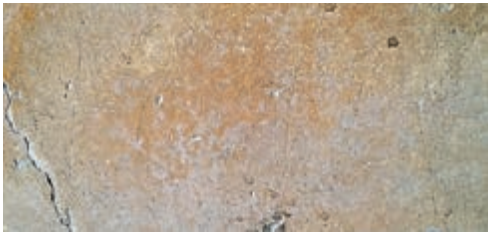

Fig. 3.



Fig. 4.

“augustiani” parteciparono (*CIL* IV 1421 con add. p. 207, 1422, 2508 con add. p. 224). La famiglia dei Cuspii Pansae si occupò della ricostruzione dell’anfiteatro.⁵

È interessante che tra i nomi scritti sotto il disegno del labirinto della Casa di Marcus Lucretius appaia anche un Ianuarius Neronis, cioè uno schiavo dell’imperatore, come se ci fosse una connessione tra la visita dell’imperatore e la casa del nostro Marco Lucrezio. È forse appunto in quel periodo che il proprietario, ancora giovane, della Casa di Marco Lucrezio potrebbe aver ricevuto la lettera illustrata nella pittura della sua casa in cui venne designato come decurione e flamine di Marte.

Se egli abbia poi continuato la sua carriera politica, difficilmente potrebbe trattarsi di altri se non di Marcus Lucretius Fronto, politico di primissimo piano degli ultimi anni di Pompei, come già è stato suggerito da altri.⁶

Visitatori illustri di età moderna della casa

Voglio terminare questa mia rapidissima carrellata sulle iscrizioni rinvenute nella casa ricordando che essa, tra le più famose di quelle scavate intorno alla metà dell’Ottocento, ha conservato anche il ricordo di diversi visitatori che non si sono peritati di lasciare la propria firma sulle sue pareti. Voglio parlare anche di essi, in una visione che, superando i limiti

⁵ Maiuri 1942, 86–87.

⁶ Monteix 2014, 269.

temporali e le categorie dottrinali, metta la casa stessa, con la sua storia antica e moderna, al centro dell'indagine che si è andata conducendo,

Alcuni sono probabilmente persone del luogo, forse appunto operai che parteciparono agli scavi, e che vollero “immortalarsi” soprattutto sulla parete orientale dell'ambiente 8, sul setto a sud dell'ingresso per l'ambiente 16. Vi si leggono infatti i nomi di P. Petrone (Fig. 1), di Luigi Costa (Fig. 2), di Baratta e di P. Dolone (?) (Fig. 3), mentre un Savatta (Fig. 4) è presente sulla parete sud dell'ambiente 7, ad ovest dell'ingresso.

Molto più interessante, inciso nel primo cubicolo che costeggia l'atrio a destra, l'ambiente nr. 4, è allora il nome *V. Klassovskij* scritto in caratteri cirillici, e l'anno, probabilmente il 1852 (Fig. 5–6). Si tratta infatti del celebre linguista russo Vladimir Ignatjevic Klassovskij (1815–1877), esperto di grammatica delle lingue slave, che nel 1848 pubblicò in russo un'ampia descrizione illustrata di Pompei (in it. *Pompei e le sue scoperte di antichità*). Di quest'opera uscirono negli anni successivi ulteriori edizioni ampliate, e anche una quarta edizione postuma nel 1883. Negli anni '50 Klassovskij sembra dunque abbia visitato la Casa di Marco Lucrezio e vi abbia graffito il suo nome. Nel suo libro, comunque, non parla di tale visita. Il graffito, da noi fotografato e rilevato nel 2004, sembra essere sparito dopo il 2007.⁷



Fig. 5.

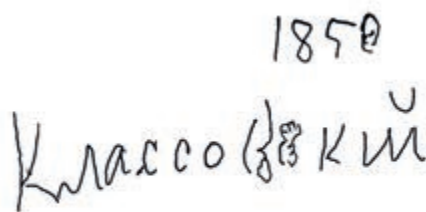

Fig. 6.



Fig. 7.



Fig. 8.

⁷ Castrén 2008, 20 con fig. 2.2.



Fig. 9.



Fig. 10.

Sulla parete meridionale dell'ambiente 19, accanto alla scala che conduce al giardino, aveva scritto, nel 1854, il suo nome un certo SCHUMAN, probabilmente francese (Fig. 7–8).⁸

E un visitatore antico

Sotto il nome di tale Schuman ho potuto leggere infine nel 2003 un graffito antico, ora solo con molta difficoltà e parzialmente leggibile, come ha potuto comunicarmi, dopo paziente ricerca, l'amico Varone. In esso si può leggere il nome (Fig. 9–10):

C. CASSI SCA[- -]

La *gens* Cassia è ben attestata a Pompei anche nella linea *C. Cassius*,⁹ mentre molti sono i cognomi iniziati per SCA e pure in uso a Pompei, tra i quali il più attestato è senza dubbio Scaurus, anche se non è ovviamente possibile propugnarlo qui con certezza. Si tratta comunque dell'unico nome completo trovato nella casa, certo lasciato da un visitatore in negligente scrittura capitale, che peraltro non ci permette nemmeno di comprendere il perché egli abbia usato il genitivo. In alternativa si potrebbe anche pensare a un nominativo sincopato, e leggere allora *C. Cassi(u)s Ca[- -]*.

⁸ Castrén 2008, 20.

⁹ Castrén 1983, 150.

Schede epigrafiche

ANTONIO VARONE

Presentazione

Le iscrizioni parietali della casa di Marco Lucrezio a Pompei, ad eccezione di pochissimi testi rinvenuti a seguito di mirata ricerca autoptica e qui ora presentati per la prima volta, sono state raccolte, nei rispettivi ambiti, nel volume IV del *Corpus Inscriptionum Latinarum* con qualche minima aggiunta bibliografica nella parte II del suo Supplemento.¹ La presentazione che qui se ne darà farà pertanto costantemente riferimento a tale basilare pubblicazione, dove da un lato è analizzata criticamente tutta la bibliografia precedente alla data di edizione del volume, dall'altro, grazie anche alla parte IV del Supplemento data di recente alle stampe,² è raccolta tutta la bibliografia successiva. Essa tuttavia concerne, al momento, i soli *tituli picti*, sì che appare congruo fare rimando ad essa per quanto concerne la più generale letteratura a riguardo di ogni singola iscrizione dipinta. Per le iscrizioni graffite, invece, in attesa che venga pubblicato il fasc. 2 della parte IV del detto Supplemento, al momento in fase di realizzazione, verrà ricordata anche la letteratura successiva all'edizione nel *Corpus*. I nuovi testi non compresi nel *Corpus*, saranno presentati in successione topografica nei vari ambienti.

Le iscrizioni dipinte trovate all'esterno della casa, sulla facciata a sinistra e a destra dell'ingresso al civico nr. 5, sono registrate rispettivamente ai numeri 875–878 e 880 e sono purtroppo tutte andate perdute. Si prescinde al momento dalle altre iscrizioni rinvenute sui muri esterni degli altri civici dell'isolato. Il *titulus pictus* famosissimo rinvenuto invece all'interno della casa e ora conservato al Museo Archeologico di Napoli è riportato al nr. 879. Quanto ai graffiti, invece, essi sono ricordati ai nr. 2331–2340 e sono purtroppo egualmente tutti andati perduti. Si aggiungono ad essi i pochi inediti prima ricordati, separatamente presentati.

Tituli picti

1) CIL IV 875 con add. p. 1277. Sul setto di parete a settentrione del civico nr. 5 dell'*insula* IX 3 a lettere nere alte circa 15 cm su bianca calcina. Dell'iscrizione ora perduta non restano nemmeno immagini fotografiche o disegni.

¹ *Corpus Inscriptionum Latinarum, vol. IV: Inscriptiones Parietariae Pompeianae Herculanae Stabianae*, edidit Carolus Zangemeister, Berolini 1871; *voluminis IV Supplementum. Pars II*, edidit August Mau, Berolini 1909.

² *Corpus Inscriptionum Latinarum, voluminis IV Supplementum. Partis IV fasciculum primum ad titulos pictos spectantem* ediderunt Volker Weber, Antonio Varone, Roberta Marchionni, Jana Keprtová, Berlin/Boston 2011.

C(aium) · Iulium · Polybium · Īv(irum). Studiosus et pistor

Le lettere LYBI del nome Polybium erano già scomparse al momento dell'autopsia di Zangemeister.

L'iscrizione è un manifesto elettorale in appoggio alla candidatura al duovirato di Caius Iulius Polybius, personaggio molto attivo nella vita politica degli ultimi periodi della città e collegato sul piano elettorale con le più importanti famiglie dell'aristocrazia cittadina.³ La sua candidatura al duovirato, la magistratura alta di Pompei, va posta in età flavia,⁴ forse verosimilmente proprio negli ultimi anni di vita della città,⁵ anche se non appare congruo volerla fissare puntualmente al 78⁶ come pure al 73,⁷ non sembrando dirimenti gli elementi avanzati al riguardo.

I maggiori problemi interpretativi offerti dall'iscrizione riguardano tuttavia i termini *studiosus et pistor* della sua chiusa. Comparando essi infatti al nominativo e nel luogo solito riservato al nome dei *rogatores*, ossia dei fautori del manifesto, come tali sono stati interpretati e, se pur col beneficio del dubbio, il presunto *Studiosus*, sia da Zangemeister che da Mau è stato considerato come un possibile nome proprio.⁸ Sembra evidente come tale soluzione appaia del tutto disarmonica e già Della Corte⁹ affermò decisamente non trattarsi di un *cognomen*, chiamando a suo sostegno già quanto precedentemente detto dall'Avellino.¹⁰ In effetti con sfumature diverse sia *studiosus* che *pistor* sono stati considerati da vari autori come *rogatores* citati con una loro qualifica e non già con il nome.¹¹ Della Corte, in verità, si era spinto più oltre, identificando, sulla scorta di quei suoi arzigogolati ragionamenti che sovente trasformavano le ipotesi in certezze, nello *studiosus* Terentius Neo e nel *pistor* suo "fratello" Terentius Proculus.¹² Tali attribuzioni sono tuttavia di pura congettura, e su di esse pertanto, avendo un'alternativa interpretativa, non mi soffermo, anche se hanno trovato seguito, come pure -ovviamente- dissensi e alternative, in letteratura.¹³

³ Un'attenta disamina a tutto tondo della figura di questo originale e complesso personaggio, *homo novus* e al tempo stesso accanito conservatore, di cui conosciamo anche la ricca abitazione posta lungo la via dell'Abbondanza, è stata di recente da me fatta in Varone 2015 e ad essa rimando per ogni approfondimento.

⁴ Cfr. e.g. Castrén 1983, 179; Mouritsen 1988, 42 con n. 183 (p. 191).

⁵ Per un anno compreso tra il 76 e il 79 si esprime Chiavria 2002, 135.

⁶ Cfr. e.g. Étienne 1992 (1966), 104; Staccioli 1982, 108.

⁷ Cfr. Franklin 1980, 68 e tav. 6.

⁸ Zangemeister, *CIL IV, Indices*, p. 238 col. 1; Mau, *CIL IV, Suppl., Indices*, p. 754 col. 1

⁹ Della Corte 1965, 157 n. 4.

¹⁰ F. M. Avellino, in *Bull. Archeol. Nap.*, II, 1844, 86.

¹¹ Cfr. e.g. Castrén 1983, 179; idem 2008, 29; Mouritsen 1988, 171. Per quest'ultimo, in particolare (n. 510 a p. 212), *studiosus* significherebbe "energetic, zealous", corresponding to *gaudens* and *cupidus*", in contrapposizione allo *studiosus (iuris)* come inteso da Della Corte.

¹² Della Corte 1965, 157–160.

¹³ Per un'analisi dettagliata di essi cfr. V. Weber, *CIL IV, Suppl. IV. 1*, p. 1276s. ad 871. Già Della Corte, del resto, era dovuto intervenire sul tema in difesa della sua attribuzione, soprattutto contrastando la visione di Magaldi 1928, che vedeva i due termini riferiti ad un'unica persona, identificata peraltro in P. Paquius Proculus. Cfr. in particolare Della Corte 1965, 160 n. 2 con la letteratura ivi citata. Castrén 2008, 29 ha invece di recente proposto per il *pistor* il citato Proculus, mentre per lo *studiosus* affaccia l'ipotesi che possa trattarsi dello stesso Marcus Lucretius a cui si attribuisce la casa (v. iscrizione nr. 6).

In alternativa radicale a tale strada va infatti individuata la possibilità che *studiosus* et *pistor* siano termini designanti non già i *rogatores*, bensì delle qualificazioni positive del candidato.¹⁴ Il fatto che esse siano espresse in nominativo non sarebbe del tutto inconsueto, potendosi citare a conforto altre iscrizioni elettorali pompeiane, quali ad esempio *CIL* IV 222. 429. 768. 3678. 3702. 3771. 3775. 3848. 7187. 7346. 7463, in cui ai candidati nominati in accusativo si abbina una frase ellittica o ad essi riferita che li vede come soggetti. D'altra parte un programma elettorale a favore del nostro Iulius Polybius vanta che egli *panem bonum fert*,¹⁵ mentre potrebbe non essere un semplice caso l'appoggio a lui offerto nella candidatura al duovirato dai *pistores*.¹⁶ Si consideri poi che nel panificio di recente scavato lungo via dell'Abbondanza (*Reg. IX, ins. 12, nr. 6–7*), meglio conosciuto come casa dei Casti Amanti,¹⁷ sono state di recente lette su una macina in rosso proprio le iniziali *C · I · P*.¹⁸ Esse parlerebbero appunto a favore della proprietà del panificio da parte del Nostro, confermando di fatti un'ipotesi già precedentemente altrimenti da me ventilata.¹⁹ Tutto ciò ben giustificherebbe quindi per Polibio l'appellativo di *pistor* al quale volutamente si abbinerebbe in una studiata contrapposizione quella di "dotto, intellettuale" (*studiosus*), come peraltro trasparirebbe dai sofisticati arredi d'arte rinvenuti nella ricordata casa di via dell'Abbondanza.²⁰

2) *CIL* IV 876 con add. p. 1277. Sulla sommità del setto di parete a settentrione del civico nr. 3 dell'*insula* IX 3 a lettere nere su bianca calcina. Dell'iscrizione ora perduta non restano nemmeno immagini fotografiche o disegni.

M(arcum) · Holconium
Priscum · aed(ilem) · ô(ro) û(os) f(aciatis)

Le lettere OVF del secondo rigo si presentano nel consueto nesso.

Il manifesto è un sostegno alla candidatura all'edilità di Marcus Holconius Priscus, magistrato negli ultimi anni di vita di Pompei, cui dovette arridere l'elezione, dal momento che poi lo si trova anche candidato al duovirato. La sua candidatura all'edilità viene posta

¹⁴ Tale posizione, sostenuta e argomentata da Varone, in *RStPomp*, V, 1991–2, 200, è stata accettata anche da Chiavria 2002, 265s. ad nr. 14 e da Monteix 2014, 266 con n. 32. Essa, peraltro, era stata già precedentemente prospettata da Sergejkeno 1953, 99.

¹⁵ *CIL* IV 429.

¹⁶ *CIL* IV 886. Sul significato da concedere a questo plurale, così come a tanti altri relativi ad attività professionali o di altra natura cfr. ora Monteix 2018, particolarmente 312s.

¹⁷ Cfr. in generale per esso Varone 2000, 314–329.

¹⁸ N. Monteix et al., *Chronique des activités archéologiques de l'École française de Rome. Les cités vésuviennes: Pompéi*, pistrina, 2013 § 41 con fig. 20 (pubblicazione solo in rete: <https://journals.openedition.org/cefr/954>); idem et al., *Bull. SFER* 2014, 323; Monteix 2014, 269.

¹⁹ Varone, in *RStPomp*, III, 1989, 236.

²⁰ Per Sergejkeno 1953, 99 il termine *studiosus* starebbe invece ad indicare la cura degli interessi del popolo da parte di Polibio.

da alcuni studiosi al 75 o al 76,²¹ quella al duovirato quasi concordemente da tutti al 79.²² Michele Stefanile, tuttavia, che già prima²³ si era mostrato indeciso tra il 78 e il 79 per la sua candidatura al duovirato, più di recente²⁴ ha preferito optare per essa invece per il 77 o il 78, senza tuttavia offrire al momento motivazioni per tale sua scelta, che va quindi considerata con grande cautela.

3) CIL IV 877 con add. p. 197. 1277. Nello spazio sottostante l'iscrizione precedente e sovrastante quella al nr. 1 a lettere nere su bianca calcina. Dell'iscrizione, ora perduta, non restano nemmeno immagini fotografiche o disegni.

A(ulum) Vettium Caprasium
[- - - - -]

L'iscrizione, di cui è andato completamente perso il secondo rigo, si riferisce ad Aulus Vettius Caprasius Felix, che secondo la maggior parte degli studiosi fu candidato alle magistrature nel primo quinquennio degli anni 70 (in particolare all'edilità nel 71 o nel 72 e al duovirato nel 74).²⁵ Non è ovviamente possibile precisare per quale delle due cariche egli concorresse nella presente iscrizione.

4) CIL IV 878 con add. p. 1277s. Nello spazio compreso tra le iscrizioni nr. 2 e 1, senza la possibilità di poter precisare il suo rapporto spaziale con l'iscrizione nr. 3. Dell'iscrizione, ora perduta, che doveva essere comunque a lettere nere, non restano nemmeno immagini fotografiche o disegni.

M(arcum) · Holconium d(ignum) [r(ei) p(ublicae)]
o(ro) v(os) f(aciatis)
Virrius · Secundus · rog(at)

L'iscrizione, tradita attraverso le testimonianze di Theodor Mommsen, Francesco Maria Avellino e Raffaele Garrucci, venne edita da Zangemeister nel *CIL* con la sottolineatura delle incertezze di lettura offerte dalla tradizione del testo. Quella più rimarchevole riguarda il nome Virrius, ritenuto di lettura non del tutto certa da Mommsen e letto Verrius da Garrucci, laddove l'Avellino lesse l'intero secondo rigo come *Verecundissimum* e Matteo

²¹ V. per essi Weber, *CIL IV Suppl. IV. 1*, 1178 ad *CIL IV 140* e cfr. anche 1199 ad *CIL IV 291*.

²² Cfr. Weber, *CIL IV Suppl. IV. 1*, 1169 ad *CIL IV 103* e 1199 ad *CIL IV 291*.

²³ Stefanile 2016, 89.

²⁴ Stefanile 2018, 612.

²⁵ Per tali datazioni cfr. la sintesi della letteratura operata da Weber, *CIL IV Suppl. IV. 1*, 1183 ad *CIL IV 174*.

Della Corte²⁶ addirittura pensò doversi leggere Lucretius Secundus, dal momento che tale nome compariva nell'iscrizione di seguito riportata al nr. 6.²⁷ Viene generalmente accettata dagli studiosi, sia pur dubbiosamente, la lettura Virrius,²⁸ mentre incertezze si riscontrano anche a riguardo del candidato al quale il testo si riferisce. Al nome di Marcus Holconius rispondono infatti due candidati pompeiani di età flavia, Priscus e Rufus, ma nel nostro caso, tuttavia, considerando i vicini programmi *CIL* IV 876 (qui al nr. 2). 880. 887. 890 riferentisi a Priscus, nonché il fatto che di programmi certamente attribuibili a Rufus ne conosciamo uno solo (*CIL* IV 7140 *a*), contro i circa 70 riferiti a Priscus, possiamo ben ritenere che anche il presente si riferisca al meglio delle probabilità a lui.²⁹ Per tale magistrato cfr. quanto detto sopra al nr. 2.

5) *CIL* IV 880 con add. p. 197. 1278. Sul setto di parete a meridione del civico nr. 5 dell'*insula* IX 3 a lettere nere alte, le più grandi, circa 24 cm su bianca calcina. Dell'iscrizione ora perduta non restano nemmeno immagini fotografiche o disegni.

*M(arcum) · Holconium aed(ilem) ô(ro) v̂(os) f(aciatis)-rogat
Sabinus ·*

Nell'iscrizione le lettere riferite al candidato sono molto più alte delle altre. La formula OVF è nel consueto nesso. Il dubbio avanzato da Zangemeister che *Sabinus* andasse letto prima di *rogat* (evidentemente la disposizione di tali parole sulla parete si mostrava alquanto diversa da quella rappresentabile nell'edizione a stampa) sembra in ogni caso doversi fugare per i confronti apportati dallo stesso Zangemeister e da molti altri ancora.

Sull'identità del nostro Marcus Holconius, da ritenersi quasi certamente Priscus, cfr. quanto detto a proposito dell'iscrizione nr. 4. Per le datazioni delle sue candidature, qui certamente quella relativa all'edilità, cfr. invece quanto detto al nr. 2.

Niente può dirsi invece a proposito del Sabinus rogatore del manifesto, trattandosi di un nome abbastanza comune. Certamente però non può darsi credito all'opinione di Della Corte³⁰ che si tratterebbe di un M. Lucretius Sabinus, dal momento che il manifesto è stato rinvenuto sulla porta di quella che viene ritenuta appunto la casa di Marcus Lucretius, in ragione dell'iscrizione successiva.

²⁶ Della Corte 1965, 161 con n. 5.

²⁷ V. a riguardo le giuste critiche mosse da Castrén 2008, 29.

²⁸ Cfr. ad es. Castrén 1983, 242; Dwyer 1982, 23; Mouritsen 1988, 171; Chiavia 2002, 351.

²⁹ La questione è stata ben sintetizzata da Weber, *CIL* IV *Suppl.* IV. 1, 1277s. ad *CIL* IV 878.

³⁰ Della Corte 1965, 161. Tale opinione, già respinta da Dwyer 1982, 23 e poi concordemente da quanti hanno trattato l'iscrizione, tra cui Castrén 2008, 29, è stata stranamente accolta da Eschebach 1993, 413.

6) CIL IV 879 con add. p. 197. 1278 (= ILS 6364). Su un quadretto pittorico raffigurante un *instrumentum scriptorium* e, in alto a destra, un'epistola su papiro arrotolato e sigillato rinvenuto sulla parete settentrionale dell'amb. nr. 20 e ora conservato a Napoli nel Museo Archeologico, inv. n. 9818. L'iscrizione, che compare a caratteri neri alti pochi millimetri come indirizzo del destinatario dell'epistola, lunga cm 12,5, è posta sia a sinistra che a destra del sigillo rosso ed è oggi non più ben visibile.³¹ Essa compare nei più noti repertori di iscrizioni pompeiane così come il quadretto in quelli di pitture³² anche se appaiono distinguibili molti più caratteri di quelli riportati da Zangemeister nella sua autopsia (p. 197). Si precisa che i segni riportati sulla tavoletta cerata presente sulla sinistra del quadretto, pur imitando la scrittura, non sono tuttavia alfabetici (Fig. 1–2, p. 227).



Fig. 1.



Fig. 2.

*M(arco) Lucretio flam(ini) ⚡; ⚡ Martis decuri
Pompei[s] oni*

Alla prima riga entrambe le E sono scritte nella consueta forma corsiva a duplice tratto verticale (II). Non è possibile ora valutare con precisione se in tal modo sia stata scritta anche la E del secondo rigo, come vista da Giulio Minervini³³ a differenza di Zangemeister e come non sembra potersi escludere. Ancora alla prima riga, tra le lettere FL ed AM è stato lasciato uno spazio, ma anch'io non credo, al pari degli altri editori dell'iscrizione, che le lettere debbano intendersi come appartenenti a due parole separate.³⁴

Il rinvenimento di tale pittura in una casa lascia decisamente pensare che il Marcus Lucretius in essa ricordato ne sia stato il proprietario³⁵ o quantomeno uno stretto congiunto. Di tale M. Lucretius essa ci dice trattarsi di un decurione, ossia nella grandissima maggioranza dei casi un ex magistrato, se non un *adlectus* per meriti speciali, nonché sacerdote di Marte.

³¹ Autopsia con rilievo fotografico da me effettuata nel 2004.

³² Per entrambi vedi la bibliografia raccolta in *CIL IV*, cui va aggiunto Castrén 2008, 27 con foto a colori e disegno p. 26; Sarullo 2008, 203; Meyer 2009, 589s. n. 3; Kruschwitz – Campbell 2009, 78s.; Loar 2018, 46 con disegno a p. 47; Baratta 2018, 32 con fig. 24 e n. 49 con altra bibliografia.

³³ In *Bull. Archeol. Nap.* 1856, 55. A tale lettura accede Sarullo 2008, 223, che tuttavia riporta anche la S finale.

³⁴ Lo stesso Zangemeister, che lascia separate tali lettere nell'edizione scioglie comunque *flam(ini)* negli indici (p. 242). Sembra forse pertanto un tantino eccessiva la menzione di tale lettura in letteratura fatta da Weber nell'apparato critico degli addenda all'iscrizione (p. 1278).

³⁵ Cfr. ad es. Della Corte 1965, 161; Castrén 2008, 27.

Su questo punto occorre fare alcune riflessioni. Il *flamen Martialis* era uno dei più antichi e prestigiosi sacerdoti della Roma arcaica e repubblicana, e tale carica era riservata peraltro, essendo uno dei tre flaminati maggiori, ai patrizi.³⁶ Pur godendo la *gens* romana dei *Lucretii* di enorme prestigio, come ben ha mostrato sopra Castrén, sembra ovviamente incongruo immaginare che tale importantissimo sacerdozio, sia pure in epoca imperiale, sia stato attribuito ad un personaggio dell'aristocrazia di una colonia. Del resto la funzione è chiamata col nome della divinità al genitivo e, come avviene per altri casi analoghi,³⁷ ciò fa piuttosto pensare si sia trattato di sacerdozi locali, sia pure importanti.³⁸ Va tenuto in conto, tuttavia, come ben notato sopra da Castrén, che a Pompei non è documentato né un tempio di Marte, né altrimenti un suo culto. Sembra allora probabile che tale flaminato vada piuttosto messo in relazione con la riforma delle cariche religiose attuatasi con Augusto, che volle rivitalizzare e in qualche modo restaurare quelle tradizioni anche religiose che si erano perse nel tempo, allargandone anche il campo d'azione. In tale ottica potrebbe infatti avere senso la missiva sigillata inviata a Pompei al decurione Marcus Lucretius, quale conferimento da parte dell'imperatore, in qualità di *pontifex maximus*, proprio della carica religiosa prestigiosa di *flamen Martis*, ovviamente non nell'ambito statale, bensì in un ambito certamente decentrato di cui purtroppo poco sappiamo, ma di cui riusciamo tuttavia a cogliere qualche indizio.³⁹

Se così stanno le cose la pittura, che è di quarto stile, ossia databile all'incirca tra il 45 e il 79 d. C. potrebbe rappresentare allora il ricordo fatto dal proprietario della casa dell'alta onoreficenza assegnata ad un suo diretto antenato. Naturalmente ciò va considerato soltanto come ipotesi, dal momento che per tutta l'età imperiale troviamo dei M. Lucretii impegnati in cariche magistraturali cittadine⁴⁰ per i quali faccio rimando appunto a quanto detto sopra da Castrén. In particolare M. Lucretius Epidius Flaccus, *praefectus iure dicundo* nel 33–34 e successivamente quinquennale nel 40–41⁴¹ fu nominato dall'imperatore Caligola, chiamato nel 33–34 in quell'anno a far da duoviro a Pompei, quale suo sostituto in tale carica. Altra e più suggestiva ipotesi, quindi, potrebbe essere appunto quella di vedere nella lettera sigillata del dipinto il rescritto imperiale di Caligola contenente tale delega.

Se infine coglie nel vero Castrén⁴² nell'affermare che M. Lucretius Epidius Flaccus possa essere stato proprio il padre del M. Lucretius proprietario della casa IX 3, 5, potrebbe

³⁶ Cfr. E. Samter, s.v. *flamines* in *RE* VI 2, col. 2484.2492, partic. col. 2486.

³⁷ Vedili raccolti in Pasqualini 2008, 440 n. 18.

³⁸ Cfr. anche Agnati 1999, 80, che sottolinea la funzione sacerdotale dei *flamines* locali nell'espletamento del culto dell'imperatore divinizzato.

³⁹ Altri *flamines Martis*, che sono noti nelle tre Gallie possono forse fornire appunto tali indizi. Così da *CIL* XII 2536 (*flamen Martis Viennae*) rinvenuto nella città di Vienne verificiamo intanto che si trattava di sacerdozi locali. Da *AE* 1934, 168, poi, dedicata a *Marti Augusto* possiamo cogliere un qualche legame tra il flaminato di Marte (*flamen Martis*) e quello istituito di Augusto, che era poi il vero scopo, con l'istaurazione del culto dell'imperatore vivente e successivamente di quello defunto divinizzato, della restaurazione religiosa operata da Augusto, ben avvertibile soprattutto nelle province occidentali dell'impero.

⁴⁰ Sulla famiglia pompeiana dei Lucretii cfr. Castrén 1983, 95. 185s.

⁴¹ Per lui e per le iscrizioni che lo citano v. essenzialmente Castrén 1983, 104. 106. 186.

⁴² Castrén 2008, 28.

appunto chiudersi il cerchio con il pensare che sia da costui ricordato l'alto onore ricevuto dal padre. Ovviamente nessuna certezza abbiamo al riguardo e la questione deve essere ancora lasciata necessariamente nel dubbio.⁴³

Graffiti

7) **CIL IV 2331 con add. p. 218.** Sulla facciata occidentale del pilastro posto all'angolo nordorientale del giardino 18, e ora non più conservata. La posizione, ben precisata da Zangemeister, è stata, dopo qualche fraintendimento,⁴⁴ di recente ribadita da Loar⁴⁵ (v. *infra*). L'iscrizione è posta coi primi due righi sopra il disegno di un labirinto realizzato con qualche incertezza grafica⁴⁶ e accanto ad esso col terzo rigo, composto da una sola parola che compare spezzata con le prime sue tre lettere poste a sinistra di esso e le altre a destra. Dell'iscrizione, di cui Zangemeister, al pari di altri autori del '800,⁴⁷ ha dato la riproduzione grafica (tav. XXXVIII 1), si conserva anche un disegno dovuto a La Volpe ora nel Museo di Napoli (inv. ADS 1040), più volte riprodotto (e.g. *PPM IX*, 291 fig. 23 = *Supplemento*, 597 fig. 31; Varone 2012, 426; Loar 2018, 421 fig. 6) e qui riproposto (Fig. 3), in quanto in esso compaiono anche i testi di seguito trattati.

Labyrinthus.
Hic habitat
Min ((disegno del labirinto)) *otaurus*

La scrittura è a lettere capitali tendenti al corsivo. Il disegno riproduce la forma canonica del labirinto quadrangolare univariario a sette circuiti, quale si può osservare in vari punti del mondo antico.⁴⁸ Esso compare anche su una tavoletta di Pilo risalente al XIII secolo a.C., come pure su monete di Cnosso che vanno dal IV sec. a.C. al I sec. d.C.,⁴⁹ che avevano certo circolazione e diffusione, ed è quindi di matrice colta. Sia il labirinto, opera di Dedalo, che il Minotauro, mostro generato dalle insane voglie di Pasifae, nonché le vicende di Teseo e Arianna ad essi connesse, sono ben noti nel mondo romano e tale mito viene

⁴³ Di M. Lucretius Fronto, magistrato pompeiano in età flavia, viene generalmente riconosciuta come casa quella posta nella *Regio V, ins. 4*, civico a. Cfr. a riguardo W. J. Th. Peters – E. M. Moormann, in Peters 1993, 411s. Monteix 2014, 269, pur mantenendo una posizione prudente, ritiene tuttavia che tra il M. Lucretius di questa abitazione e M. Lucretius Fronto (o anche Lerus) di quella V 4 a “le lien familial est indéniable”. Anche Castrén sembrerebbe incline a ritenere che il M. Lucretius della lettera possa anche essere stato un ancor giovane M. Lucretius Fronto agli inizi della sua carriera politica.

⁴⁴ *PPM IX*, 290, fig. 221; Sarullo 2008, 204 fig. 1.

⁴⁵ Loar 2018, 410–412.

⁴⁶ Nell'apografo di Zangemeister manca un tratto di chiusura nella parte centrale, che compare invece in altri disegni d'epoca (v. *infra*), né è possibile stabilire se ciò sia dovuto ad incuria di Zangemeister o dell'autore del disegno.

⁴⁷ La riproposizione di tali disegni con un'accurata analisi e con ulteriori notazioni bibliografiche sia rispetto al *CIL IV Suppl. IV. 1* che anche successive è fatta da Sarullo 2008, 203–210.

⁴⁸ Vedine alcuni esempi riportati in Langner 2001, tav. 7, dove compaiono anche esempi dei labirinti a forma circolare.

⁴⁹ Sarullo 2008, 208 e fig. 9 (p. 211). 215 s. e fig. 13.

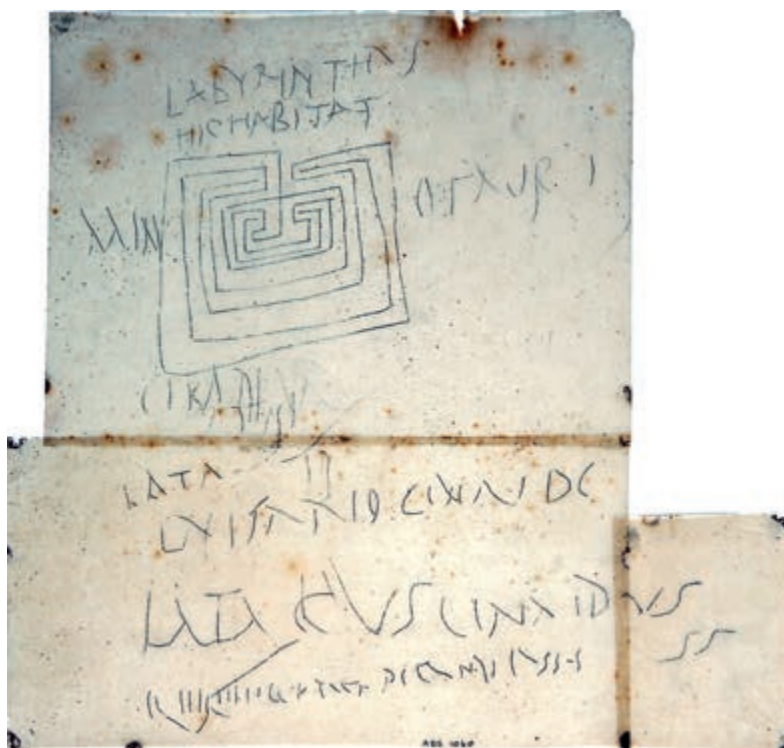

Fig. 3.

illustrato anche da Virgilio nell’Eneide,⁵⁰ cosa che ne ha favorito certamente la conoscenza e la propagazione. C’è di fatto che a Pompei esso si trova rappresentato sia in pittura che in mosaici,⁵¹ mentre ancora a sgraffio un labirinto di forma circolare è riprodotto tre volte lungo il corridoio dei Teatri.⁵² C’è poi un ulteriore accostamento tra pittura e nome del Minotauro (e forse anche del Labirinto stesso), sia pure in chiave parodistica, nell’atriolo balneare della casa del Menandro.⁵³ Tanto basta per giustificare la presenza di questo graffito in questa casa come opera di qualcuno, che avendo appreso in maniera didascalica della vicenda, abbia voluto, come è fatto tipico dei graffiti, così esternare il proprio partecipato stupore ad essa. Non penserei pertanto, come pure è stato fatto, a valori apotropaici del disegno o a riferimenti all’impianto planimetrico della casa o a un *sobriquet* del suo padro-

⁵⁰ Verg. Aen. VI 24–30. V 588–591. Di Pasifae parla anche Ovid. *Ars* I 289–326.

⁵¹ Si ricordino, a solo titolo di esempio tra i tanti che si rifanno a tale mito nel suo complesso, il celeberrimo quadro di Teseo che libera i fanciulli di Atene dopo aver ucciso il Minotauro dalla casa di Gavio Rufo, ora al Museo di Napoli, inv. nr. 9043, o il mosaico che dà il nome stesso alla casa del Labirinto (v. ad es. Strocka 1991, 100).

⁵² Vedili in Langner 2001, tav. 7 nr. 152–154 con p. 30s., dove peraltro non viene citato il nr. 152.

⁵³ Vedi ad es. Maiuri 1932, 129s e per le iscrizioni v. *CIL* IV 7352 con Varone – Stefani 2009, 126–129 e tav. XI.

ne⁵⁴ e men che meno a marcate allusioni ai comportamenti sessuali devianti da leggere in corrispondenza con altri graffiti vicini.⁵⁵

Raoul-Rochette 1852, 300s. (manca in *CIL*); Diehl 1930, 53; Mallon – Marichal – Perrat 1939, n. 6, 10; Heller 1946, 126; Geist 1960, 76s. nr. 4; Lindsay 1960, 88; Krenkel 1961, 36; Heller 1961, 60 e tav. 33, 13–14; Kern 1983, 98 nr. 107; Maulucci Vivolo 1993, 190; Weeber 1996, 87 n. 268; *PPM IX*, 1999, 290 s. n. 223 (I. Bragantini); Langner 2001, 30. 34. 35. e tav. 7 fig. 150; Saward 2003, 46s.; Cooley – Cooley 2004, 76 nr. D 83; García y García 2005, 151; Wallace 2005, 89 nr. 183; Castrén 2008, 28; Sarullo 2008; Hunink 2011, 857; Lohmann 2018, 74; Loar 2018, 408. 427.

8) *CIL IV 2332*. Al di sotto dell'iscrizione precedente (Fig. 3). Di esso, che non si conserva, rimane l'apografo dovuto a Zangemeister (*CIL IV* tav. XXXVIII 2) e il disegno di La Volpe sopra riportato alla fig. 13 e più volte riprodotto (e.g. *PPM IX*, 291 fig. 23 = *Supplemento*, 597 fig. 31; Varone 2012, 426; Loar 2018, 421 fig. 6). L'iscrizione è di difficilissima lettura, e ciò si evince anche dalle differenze alquanto marcate riscontrabili nei due apografi citati, sì che il testo non può in nessun modo essere fissato con certezza e va preso quindi con tutti i benefici del dubbio.

Pur seguendo per praticità la versione data da Zangemeister avverto subito che l'esame paleografico mi porta a considerare che si tratti di 4 o anche 5 iscrizioni separate, scritte certamente da almeno tre mani diverse, che distinguo con lettere da *a* a *e*.

a) immediatamente al di sotto del disegno del Labirinto

CIBADI vâ(le)
TISIS

Lettura assolutamente incerta, scaturita dal disegno di La Volpe. Al primo rigo al posto del gruppo CI potrebbe leggersi O e al posto di B leggersi K. Anche il seguente gruppo DI potrebbe leggersi RI e in esso la I potrebbe anche essere una E. In ogni caso in nessuna delle varianti prima esaminate si riuscirebbe a vedere un nome sensato, a meno di non voler intendere come tale un fantomatico nome *Cibarius*. Anche il secondo rigo rimane del

⁵⁴ Una carrellata di tali opinioni può trovarsi in Sarullo 2008, 213 s. 219.

⁵⁵ Sarullo 2008, 212, era propensa a ritenere che il primo rigo dell'iscrizione sia stato vergato insieme al disegno, mentre solo in un secondo momento si sarebbero scritti gli altri due rigi, cosa che avrebbe determinato la tmesi del nome Minotaurus. Loar 2018, 423–425, sviluppando tale osservazione, immagina allora che tali altri due rigi vogliano “dialogare” col primo e soprattutto con gli altri graffiti posti lì da presso, che ricordano dei cinedi (v. *infra*), quasi a *memento* (moralistico?) dei guasti che passioni innaturali possono determinare. Senza entrare nel merito sull'attendibilità storica della valenza di un tale pensiero, ritengo in ogni caso si possa e si debba comunque prescindere in questa sede da siffatte inverificabili illazioni. Al Labirinto cretese pensa di fatto anche W. Buchwald, in *ThLL* s. v. *labyrinthus*, 814, 49.

tutto inspiegato. Si noti che Zangemeister non riporta proprio nella tavola tali lettere, pur facendo riferimento ad esse nel commento all'iscrizione appunto con rimando alla tavola. La lettura che ne riporta, OPAISII, che peraltro ignora del tutto il secondo rigo, è incompatibile col disegno di La Volpe. Zangemeister riporta anche la lettura data da Garrucci OBAD, avvertendo che sotto la D egli aveva visto le lettere TIIS, cosa che ci spinge a dar fiducia comunque al disegno di La Volpe. Non escludo, però, che la lettura "impossibile", non ben leggibile e male interpretata, possa in effetti nascondere le stesse parole che si ritroveranno negli altri testi sotto riportati e che quindi i due rigi vadano piuttosto intesi come CINAI[I]DI[I] *va(le)* | [LA]T[A]R[IV]S.

b) Al di sotto delle lettere prima riportate, scritto da altra mano.

Lata[ri]e ?

La resa della L e della A sono caratterizzanti del *ductus* di tale testo, che sia pure in maniera molto dubitativa, sulla scorta di quanto si può leggere nei testi seguenti, interpreterei, al pari di Guzzo e Scarano Ussani, come un vocativo dell'enigmatico nome *Lattarius*, per cui v. *infra*. La E è resa con i due tratti verticali.

c) Al di sotto del rigo precedente, scritto da altra mano.

La[t?]tario cina[e]de

Dopo le prime due lettere è possibile dal disegno di La Volpe sia leggere una E (II), sia una semplice I, sia una T senza il tratto orizzontale, cosa questa da ritenere però la più probabile, visto che essa viene data come certa da Zangemeister, e prima di lui da Garrucci e da Minervini. Zangemeister peraltro avverte che il gruppo RI potrebbe anche solamente rappresentare una N, cosa che invero non sembra per niente probabile, considerando i testi scritti prima e dopo. Che nella parola seguente, dopo la A, della E sarebbe visibile un solo tratto verticale è confermato anche da Garrucci, che legge CINAIDE, oltre che dal disegno di Zangemeister e da quello di La Volpe, mentre il solo Minervini legge CINAED-DE. Concorde è la lettura della E finale della parola, che tuttavia nel disegno di La Volpe potrebbe dare adito a pensare che si sia invece trattato del primo tratto di una O. Se così fosse avremmo una frase in dativo formata dal nome *Lattarius* e dall'apposizione *cinaedus*, ma tale caso susciterebbe perplessità interpretative. D'altro canto, la lettura comunemente accettata *cinaede* porterebbe a leggere il nome *Lattario* ugualmente come vocativo (o nominativo *pro* vocativo), ma sia nel testo precedente, sia in quello successivo la forma più accreditata per tale nome sembrerebbe essere *La(t)tarius*. E' evidente, quindi, che qualcosa non torna ed è doveroso mettere in discussione la lettura stessa tradita. A complicare di

più la questione si aggiunge poi il fatto che né *Lattarius*, né *Latarius*, né *Latario* sono nomi mai prima attestati. La spiegazione più naturalmente spontanea per tale nome potrebbe eventualmente essere il metterlo in riferimento derivativo con il vicino *Lactarius mons* con progressivo passaggio fonetico del gruppo CT a T (o TT),⁵⁶ mentre del tutto evanescente appare la connessione con *lac* in riferimento osceno, stante l'appellativo di *cinaedus*.⁵⁷ Decisamente più calzante in relazione al latte, potrebbe invece essere quella avanzata sopra da Castrén.

Anche la lettura LAITARIO,⁵⁸ infine, desunta dal disegno di La Volpe, non risolvrebbe la situazione, portando in scena, anzi, un nome inaudito e per giunta nemmeno spiegabile. In conclusione, su tale testo permangono irrisolti dubbi.

d) Al di sotto del precedente, scritto forse dalla stessa mano.

Lata[ri]us cinaedus

Zangemeister avverte che nella prima parola tra la lettera A e la lettera V, dove compaiono diverse linee “allogrie” potrebbe leggersi o il gruppo CC, o la lettera B o la lettera C. Osservando il disegno di La Volpe vien da dire che potrebbe ben leggersi anche una G, e non a caso Garrucci legge LATAGVS e Minervini, pur con palese errore della doppia T, legge LATTAGVS. Con Guzzo – Scarani Ussani si passa invece alla forma LATA[RI]VS, che appare compatibile pur se non con immediatezza col disegno di La Volpe ed è quella più congrua, visti i testi precedenti.⁵⁹ Ancora la seconda parola, letta CINAIDVS dal solo Garrucci, e così ben chiara nel disegno di La Volpe, trova nella tavola di Zangemeister la sua giustificazione per la “naturale” lettura come CINAEDVS.

In definitiva, e grazie soprattutto al reciproco confronto col testo *b)* sembrerebbe nel graffito di poter riconoscere un nome *Latarius* (per il quale v. sopra) seguito dall'apposizione *cinaedus* come nominativo messo al posto del vocativo,⁶⁰ a meno di non volerlo considerare scritto in unione col testo seguente, cosa non del tutto da escludere, ma che non sembra tuttavia molto probabile.

e) Al di sotto del precedente e scritto, a differenza degli altri, in corsivo, cosa che non lascia ben intendere se sia dovuto alla stessa mano che ha vergato il testo precedente, anche se la cosa non sembra probabile. I caratteri sono comunque più piccoli rispetto a quelli del testo richiamato.

⁵⁶ Cfr. Väänänen 1966, 63s.

⁵⁷ Cfr. Loar 2018, 420.

⁵⁸ Proposta da Loar 2018, 420.

⁵⁹ Loar 2018, 420, pur preferendo trascrivere LATA[- -]VS (*sic!*), fa continuo riferimento al nome *Latarius*.

⁶⁰ Uso quanto mai comune a Pompei. Cfr. Väänänen 1966, 115.

Quem eg[o] peto? pygandi? lassus [- - -]SS[- - -]

Dell'iscrizione si legge con certezza solo l'inizio QVIIM IIG e il gruppo ASSVS verso la fine. Sia il verbo PETO che PYGANDI appaiono compatibili con il disegno di La Volpe e con la tavola di Zangemeister. Del tutto illeggibile e ininterpretabile invece il finale con le due sole SS chiare. La lettura di Garrucci QVIIM IIGO PIITO PYGANDO LASSVS, LACSSA è riportata da Zangemeister, che comunque preferisce astenersi da ogni integrazione, ma confermando tuttavia il termine LASSVS. Guzzo – Scarano Ussani sorvolano del tutto su tale rigo, al pari di Minervini, laddove Loar⁶¹ aderisce alla proposta di lettura da me precedentemente data, sostanzialmente simile a quella qui riportata, con interessanti ulteriori considerazioni sul significato di tale oscena espressione. Devo però anche rilevare che dal disegno di La Volpe potrebbe anche leggersi CASSVS e non già LASSVS, così come del resto PASSVS, con modifiche alquanto consistenti nel significato pur sempre osceno della frase, ma va ritenuta decisiva al riguardo la testimonianza comune di Garrucci e Zangemeister sulla L ad inizio di parola. Quanto a PYGANDI, sarebbe il gerundio di un non mai documentato verbo latino, ma chiaramente formato sul greco $\pi\upsilon\gamma\acute{\iota}\zeta\omega$, equivalente al latino *paedico*.

Guzzo – Scarano Ussani 2009, 141 (con l'inesatta collocazione topografica V 3, 9); Varone 2012, 426; Loar 2018, 420–423. 427.

9) CIL IV 2333. Al di sotto dell'iscrizione precedente e ugualmente non conservato. L'apografo di Zangemeister a tav. XXXVII 7, che mostra lettere molto allungate, dà ragione della sola prima parola, lasciando non ben percettibile la seconda, ancora più oscura del resto nel disegno lasciato da Garrucci, che peraltro dà del tutto una lettura assolutamente improponibile, che si preferisce tralasciare. Zangemeister avverte che la lettura di tale seconda parola come NIIRONIS è solo frutto di congettura desunta dal confronto con l'iscrizione CIL IV 2335, qui al nr. 11.

Ianuarius Neronis?

Il nome Ianuarius,⁶² molto comune anche a Pompei, è qui appannaggio probabilmente di un servo di Nerone, ricordato anche nell'iscrizione successiva.

Loar 2018, 413 con n. 12 (dove la seconda parola è letta come NIIIRON[I]S). 427 e fig. 5.

⁶¹ Loar 2018, 421 s.

⁶² Per cui cfr. Kajanto 1965, 29s. 60s. 218.

10) *CIL IV 2334*. Più in basso del precedente a cm 24 dal pluteo. Non conservato. Di esso si hanno il disegno di Garrucci e l'apografo di Zangemeister (tav. XXXVII 5), che dà comunque la lettura come certa. Lettere capitali.

*Ianuarius
cinedus*

Si tralascia la lettura improba del secondo rigo data da Garrucci. *Cinedus* è scritto al posto di *cinaedus*, con monotonghizzazione del dittongo AE alquanto solita a Pompei.⁶³ Verosimilmente si tratta dello stesso *Ianuarius* che compare nell'iscrizione precedente. Cfr. inoltre quanto si dirà *infra* a riguardo di *CIL IV 2338*.

Weeber 1996, 108 n. 347; Castrén 2008, 29; Guzzo – Scarano Ussani 2009, 141 (con l'inesatta collocazione topografica V 3, 9); Hunink 2011, 289 nr. 858; Loar 2018, 413s. 427 e fig. 5.

11) *CIL IV 2335*. La collocazione indicata da Zangemeister mi spinge a ritenere che tale graffito, non conservato, si trovasse sì sulla parete settentrionale dell'ambiente 20, ma non già nel vano rientrante dove era posto il dipinto ora staccato col papiro indirizzato a Marco Lucrezio (*CIL IV 879*, qui al nr. 6).⁶⁴ Lì infatti né si vede, né ci sono altre parti di intonaco mancanti. Esso doveva invece trovarsi sul setto di parete posto all'estremità orientale più stretta del passaggio (*pariete sinisteriore -septentrionali- extremo*) quasi dirimpetto al pilastro dove si leggevano i graffiti prima trattati (*exadversus eandem pilam*), e alquanto in basso (*non multum supra pavimentum*), proprio dove si distingue un taglio netto dell'intonaco (Fig. 4).



Fig. 4.

Dell'iscrizione, oltre al disegno di Garrucci, abbiamo l'apografo di Zangemeister (tav. XXXVIII 4). Le lettere sono in corsivo molto legato.

Restitutus Neronis

⁶³ Cfr. Väänänen 1966, 23 s.

⁶⁴ Posizione inesatta data da Loar 2018, 406 fig. 1.

La prima I è alta. Della seconda T era leggibile il solo tratto verticale. Le E sono entrambe rese con il duplice tratto verticale (II).

Anche il nome Restitutus, alquanto comune,⁶⁵ è ben presente e diffuso a Pompei. Si tratterebbe anche in questo caso di uno schiavo di Nerone.

Castrén 2008, 29; Benefiel 2010, 57–60; Hunink 2011, 290 nr. 859; Loar 2018, 414. 428 e fig. 5.

12) CIL IV 2336. Al di sotto del precedente, a cm 4,5 di distanza da esso, per la cui posizione v. sopra al nr. 11. Non conservato. Resta l'apografo lasciatoci da Zangemeister (tav. XXXVII 11). Lettere capitali tendenti al corsivo.

Ninus

Il nome grecanico Ninus⁶⁶ compare a Pompei in quest'unica attestazione.

Loar 2018, 414 n. 14. 428.

13) CIL IV 2337. Al di sotto del precedente (*ubi vide*). Non conservato. Resta il disegno di Garrucci e l'apografo di Zangemeister (tav. XXXVIII 3). Lettere corsive.

Quater Ner[onis]

Al di sotto della Q è posta un'altra Q, senza alcun significato. Dopo la seconda R Zangemeister avverte che i guasti della superficie possono far arguire che siano non più leggibili molte lettere. Tanto e il confronto con l'iscrizione CIL IV 2335 (e cfr. 2333) mi spinge a propugnare anche qui l'integrazione *Ner[onis]*, che tuttavia presuppone si intenda *Quater* come nome individuale, tuttavia non altrimenti attestato. Zangemeister di fatto tale lo ritiene (anche se forse abbreviato, cfr. CIL IV, *Indices*, p. 237), mantenendo comunque i suoi dubbi per l'integrazione *Neronis* (cfr. *Indices*, p. 248). Mau invece esprime qualche dubbio su tale cognome (CIL IV *Suppl.*, *Indices*, p. 753) e si astiene quindi da ogni integrazione per *Ner* (cfr. CIL IV *Suppl.*, *Indices*, p. 767).

Non sembra potersi prendere in seria considerazione, d'altro canto, la proposta avanzata da Carcopino di unire questa all'iscrizione seguente (*ubi vide*) correggendo il primo rigo di essa in VSVS (dove invece la T è chiarissima) e intendendo *quater Ner(one) | u's'us | Restitutus cinedus*, peraltro con arditissima costruzione del periodo.

Carcopino 1960, 155; Loar 2018, 418s. 428.

⁶⁵ V. per esso Kajanto 1965, 356.

⁶⁶ Per il quale cfr. Solin 2003, 549.

14) CIL IV 2338. Immediatamente al di sotto del precedente (*ubi vide*). Non conservato. Resta il disegno di Garrucci e l'apografo di Zangemeister (tav. XXXVIII 5). Lettere corsive.

utus
Restitutus · cinedus

La lettera E è resa con i consueti due tratti verticali (II). Nell'interpretazione del primo rigo, rifiutando la proposta di Carcopino (v. al graffito precedente) seguo Zangemeister nel ritenere che "nihil est nisi nominis Restitutus finis temere repetitus". *Cinedus*, come già visto sopra, è scritto per *cinaedus*.

Loar ritiene che la duplice apposizione di *cinedus* ai nomi dei due schiavi di Nerone, qui Restitutus e prima Ianuarius, sia frutto del mutato sentimento popolare nei confronti di Nerone, e sia quindi stata posta successivamente alla sua *damnatio memoriae*.⁶⁷ Ritiene anzi che essa voglia proprio riferirsi per traslato alla natura stessa dell'imperatore,⁶⁸ colpendola. Tale proposta, tuttavia, non trova nessun elemento probatorio e rimane quindi al livello di semplice suggestione.

Guzzo – Scarano Ussani 2009, 141 (con l'inesatta collocazione topografica V 3, 9); Hunink, 2011, 290 nr. 860; Loar 2018, 414. 428 e fig. 5.

15) CIL IV 2339. Sulla parte alta della parete settentrionale dell'ambiente 26, a sinistra della scala. Non conservato, né tradito attraverso disegni. L'unica testimonianza che ne rimane è quella di Zangemeister, che lo descrive come scritto a lettere capitali alte cm 13.

VRM A

L'iscrizione non è stata interpretata, né sembra possibile avanzare congetture.

Loar 2018, 428, con dubbi circa la pertinenza del graffito all'ambiente 26. Il preciso riferimento fatto da Zangemeister alla pianta della casa edita in *Real Museo Borbonico*, XIV, 1852, tav. AB rende tuttavia tale collocazione assolutamente certa.

16) CIL IV 2440. Al di sotto del precedente. Non conservato, né tradito attraverso disegni. L'unica testimonianza che ne rimane è quella di Zangemeister, che lo descrive come scritto a lettere alte cm 3 (la M), capitali nel *ductus* tranne che per la S, e nella resa grafica del testo evidenzia un'anomala spaziatura delle lettere che distribuisce in tal modo

MENE N IVIS VNIIAOS

⁶⁷ Castrén 2008, 29 data appunto queste iscrizioni a prima del 68.

⁶⁸ Cfr. Loar 2018, 415–420.

Sembra però qui possibile fare delle congetture. Zangemeister stesso, pur non proferendo parola al lemma, negli indici (*CIL IV, Indices*, p. 238), avanza dubbiosamente il sospetto che le lettere finali riportino il ben noto e diffuso nome grecanico *Syneros* (qui scritto con V al posto di Y) e a lui si accoda anche Mau (*CIL IV, Supplementum, Indices*, p. 754). Castrén dal canto suo legge la parola iniziale come *Menenius*, ossia con la seconda I mal letta al posto della S, laddove l'altra S sarebbe invece l'iniziale del nome *Syneros*. La gens *Menenia* è ben rappresentata a Pompei,⁶⁹ e tuttavia lo stesso è restio a considerare questo *Menenius* come pompeiano. In ogni caso credo si possa ritenere, sia pure con dubbi e cautele, che in tale scritta sia adombrato il nome grecanico di un liberto o discendente di liberti, ed editerei pertanto *Menenius Syneros*.

Loar 2018, 428, con dubbi sulla localizzazione, ma v. quanto detto al nr. precedente.

Graffiti inediti

Oltre all'iscrizione sopra presentata da Castrén, sia nella ricognizione da lui operata, sia nella mia, sono stati rinvenuti altri graffiti sfuggiti ai precedenti studiosi che si sono interessati della casa e che vengono ora qui presentati in ordine topografico.

17) Ambiente 1 (*fauces*), parete settentrionale. A cm 19 dallo spigolo ovest (ingresso all'amb. 3) e a cm 107 da terra. Incisione a punta larga con tratti duplicati. Rilievo autopottico dell'a. 1992. Foto SAP inv. D/74222 (Fig. 5–6).

0,025 *Hy(mnus)* 0,022–0,025



Fig. 5.

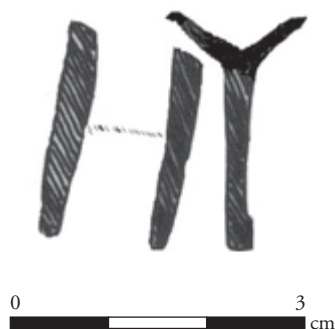

Fig. 6.

⁶⁹ Cfr. Castrén 1983, 189–191.

Vedrei nell'iscrizione l'inizio, lasciato incompiuto, del nome *Hymnus* dell'iscrizione nr 19, che ha, al pari di questa, l'asta orizzontale della lettera H molto sfuggente.

18) Ambiente 1 (*fauces*), parete settentrionale. A cm 49 dallo spigolo ovest (ingresso all'ambiente 3) e a cm 108 da terra. Lettere capitali con incisione profonda, ora purtroppo non più ben distinguibili. Autopsia a. 2019 (Fig. 7).

0,12 *L(ucius) · M+++[.]s* 0,02-0,05



Fig. 7.

La lettura è quanto mai incerta a causa delle notevoli abrasioni della parete che hanno falsato il retto riconoscimento dei tratti originari, sì che appare disperato il tentativo di interpretare esattamente il *nomen*. Le lettere appaiono racchiuse tra due linee orizzontali.

19) Ambiente 1 (*fauces*), parete settentrionale. A cm 78 dallo spigolo ovest (ingresso all'ambiente 3) e a cm 140 da terra. Incisione superficiale a punta molto sottile. Rilievo autoptico dell'a. 1992. Foto SAP inv. D/74221 (Fig. 8-9).

0,095 *Hymnus* 0,016-0,055



Fig. 8.

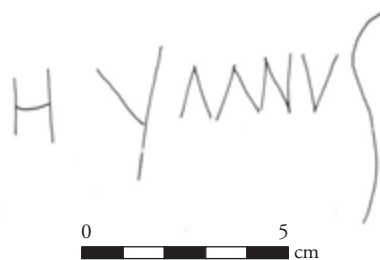

Fig. 9.

Per il nome greco Hymnus, già noto in varia forma a Pompei,⁷⁰ cfr. Solin 2003, 1262. 1459.

Castrén 2008, 29.

20) Ambiente 1 (*fauces*), parete settentrionale. A cm 91 dallo spigolo ovest (ingresso all'ambiente 3) e a cm 106 da terra. Incisione marcata, fatta a punta sottile. Autopsia a. 1992. Foto SAP D/74220 (Fig. 10–11).

IIIIII



Fig. 10.

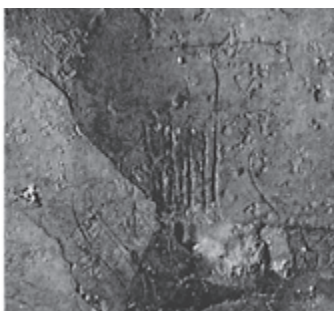

Fig. 11.

Numerale. L'ultimo tratto è notevolmente più alto degli altri e credo che ciò sia forse dovuto a voler poi caratterizzare, grazie anche ad un lungo tratto orizzontale postovi sopra, una lettera T. A sinistra e a destra del numerale, più in alto, vi sono una ripetuta serie di S, e di V, ed altre S ancora compaiono più in basso, forse da ritenere semplici esercizi di scrittura.

⁷⁰ CIL IV 5619: *Hymn(us)*; CIL IV 136*: *Ymnus*. Tale ultima iscrizione, giudicata sospetta da Zangemeister solo perché tradita unicamente da Garrucci, è a mio avviso da ritenere autentica. Mau comunque inserisce tale forma nell'indice dei cognomi accanto ad *Hymn(us)* (CIL IV, *Supplementum, Indices*, p. 750).

21) Ambiente 5, parete occidentale. A cm 27 dall'angolo nordovest e a cm 109 da terra. Lettere capitali realizzate a punta sottile. Autopsia a. 2019 (Fig. 12).

0,075 *Myronis* 0,01–0,02



Fig. 12.

Iscrizione problematica, dal momento che la terza lettera non è chiara in quanto potrebbe infatti trattarsi anche di C, di K, o di S unita ad una I. Si predilige la lettura con una R non ben riuscita, come ricordo del nome femminile *Myronis*, documentato anche a Roma.⁷¹

22) Ambiente 7, parete ovest. A cm 119 dall'angolo sudoccidentale e a cm 48 da terra. L'iscrizione non è graffita, ma è realizzata con pigmento marrone, simile al carboncino. Autopsia a. 2019.

II

Numerale.

23) Ambiente 7, parete sud. Ad est dell'ingresso, a cm 46 dall'angolo sudorientale e a cm 163 da terra. Incisione netta a punta sottile. Rilievo autoptico dell' a. 1992. Foto SAP inv. D/74225 (Fig. 13–14).

0,01 *II* 0,054

Numerale.

⁷¹ Cfr. Solin 2003, 271.

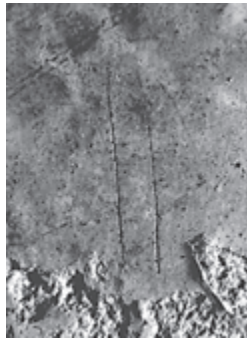

Fig. 13.



Fig. 14.

24) Ambiente 7, parete meridionale. A cm 17 dall'angolo sudorientale e a cm 153 da terra. Incisione netta, fatta a punta sottile. Autopsia a. 1992. Foto SAP D/74224 (Fig. 15-16).

0,063	IIIIIIIIII	0,039-0,048
0,013	IIIIII	0,006-0,008

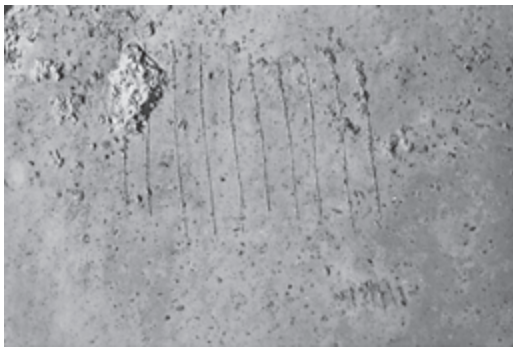

Fig. 15.

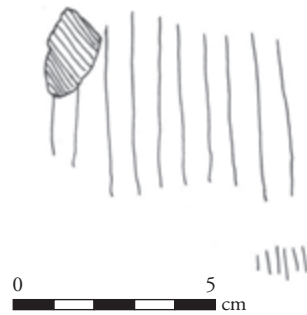

Fig. 16.

Due numerali sovrapposti. Il secondo a tratti molto più piccoli del primo.

FINDS FROM THE 1847 EXCAVATIONS

Documentation History

RIA BERG

“The house which I am about to describe can be considered
as amongst the most interesting in Pompeii”
Edward Falkener, 1852

The rich and magnificently decorated Pompeian House of Marcus Lucretius (Casa di M. Lucrezio), has deservedly attracted an exceptional amount of scholarly attention ever since its excavation in 1847 (Fig. 1).

The first, and relatively complete, inventory list of the finds from the house was made already during the excavation in March–September 1847. The hand-written *Giornale dei Soprastanti* was compiled by those responsible for the practical excavation operations, in particular by Gabriele Cirillo, who also wrote the weekly reports for the Superintendent Francesco Avellino in Naples.¹ These texts, typically for their time, rather than being archaeological documentation were meant to be accountability reports for the workers, and an inventory of finds in chronological order, with scarce reference to the exact location or context of the objects found. These original documents are stored at the *Archivio Storico* of the Naples Museum.

The text of the *Giornale*, with minor variations, was published by Giuseppe Fiorelli, who had been inspector at Pompeii at the time of the excavation, in 1862, in *Pompeianarum Antiquitatum Historia (PAH)*, vol. II, 459–474. An almost identical list had already been published in 1848 by Bernardo Quaranta, in *Annali Civili del Regno delle Due Sicilie*, an official periodical of the Bourbon reign containing cultural and statistical essays.² This list enumerates the same objects in the same daily order, but sometimes uses different synonym expressions to describe the same items, and some items are also missing. It is therefore not simply a copy of the *Giornale/PAH* list.

Guglielmo Bechi, an archaeologist and architect, was the Director of the excavations of Pompeii at the time of the unearthing of the House of Marcus Lucretius, and published regular reports on the excavations in the *Real Museo Borbonico* series. Volume XIV, published in 1852, included his account of the House of Marcus Lucretius, described as

¹ In the reports, no finds other than statues are mentioned. In 1847, Giuseppe Fiorelli started as inspector of the Pompeii excavations, Guglielmo Bechi was the director, Pietro Bianchi and Carlo Bonucci were official architects, and Giuseppe Abbate was responsible for the drawings of the site.

² Quaranta 1848.



Fig. 1. Garden view with the statues. Alma Tadema's Collection. (Cadbury Research Library, University of Birmingham.)

the most important house excavated in recent years. The structures, wall paintings, and statuary of the house are described in this text; of the smaller finds, only the elements of the chariot (Cat. 422–426) accurately found in the upper tablinum R33 and the silvered bench (Cat. 228) found in triclinium R16 are mentioned.³

The exceptional documentation produced by the English architect and antiquarian Edward Falkener (1814–1896) is based on independent documentation made on-site during the excavations (Fig. 2). Falkener stayed in Pompeii for most of the excavation season in 1847. He writes that he had obtained from the minister of the Interior Marchese Santangelo permission to attend the unearthing of a house of his own choice, to be excavated, as he states, under his “personal superintendency”.⁴ He also writes that he had “attended

³ Bechi 1852, 10; 15.

⁴ Minervini (1854, 1, n. 1) doubts that Falkener could have been given the possibility to direct the excavation: “se talvolta si concede agli stranieri di assistere ai giornalieri scavi di Pompei, riesce assolutamente nuovo che possa taluno dire di aver soprinteso quei lavori, eseguiti sotto la direzione degli ingegneri di Pompei, dell’archeologo ispettore sig. Fiorelli, e sotto la soprintendenza di un altro celebre antiquario, com’era comm. Avellino”.

the excavations several times a day, watching nearly every morsel of stone, stucco or charcoal that was turned up.”⁵ His account was first published in *The Museum of Classical Antiquities: A Quarterly Journal of Architecture and the Sister Branches of Classic Art*, in Vol. II, 1852–1853, 35–89, and was then reprinted in 1860 (Fig. 3).

Falkener’s account is remarkable for including accurate lists of finds by room, contained in footnotes following the description of the individual rooms and their paintings. This is the only source for the exact provenience of most objects. The description and identification of these objects are, however, more accurate in *PAH*, which also includes more objects. Falkener has quite evidently described many objects based on his own observations, occasionally adding some details, but in many cases his list must be a word-for-word translation of the *PAH*, even including some transcription errors. The most striking case is the Falkener’s ‘cup in rosso antico’, in the *PAH*, in fact, a sculptured bust of Bacchus in rosso antico marble (I.1.19, Cat. 94). Falkener’s stay in Pompeii ended in July–August 1847, before the excavation was completed, meaning that the latter part of his report is necessarily less well documented.

The very first printed notes on the finds from the House of Marcus Lucretius had already been made while the excavation was still going on; these were published by the German archaeologist Theodor Panofka on June 19, 1847, in the *Bullettino dell’Istituto di Corrispondenza archeologica*.⁶ The report contained sporadic information about the finds

from specific room types, cubacula, alae, triclinium, and the garden. Panofka did not, for example, mention the rich finds from cubiculum R4, but mentions the talcum plates (Cat. 130) found in R6. In two further reports published in German in the same year Panofka states that most of the bronzes of this magnificently decorated house would already have been taken away in Antiquity: “dies stattliche, bilderreiche, aber seiner Bronzeschätze schon in alter Zeit beraubte Haus...”⁷

A visitor to the ongoing excavation, Carlo Pancaldi, was given a tour of the house by inspector Fiorelli himself in July 1847, when the area of the upper atrium was being unearthed. His report, *Il*



Fig. 2. Edward Falkener (1814–1896). Drawing by Carl Christian Vogel von Vogelstein in 1847. (Kupferstich-Kabinett, Staatliche Kunstsammlungen Dresden.)

⁵ Falkener 1852, 37.

⁶ Panofka 1847a.

⁷ Panofka 1847b, 141.

magnifico Iaccheo pompeiano, published in the following year, mostly describe the Bacchic wall-paintings and statues of the house, but it also mentions some isolated minor finds – bronze cauldrons, “elegant glass buckets” and a horse bit (Cat. 306): “Dietro il Giardino, e queste Camere che gli stanno a fianco, ne visitammo alcune di minor conto...” in altre furono rinvenute parecchie eleganti *Marmitte* di bronzo, alcune vitree *secchie* pure di forma gentile, ed un *morso* per cavallo.⁸ Tantalizingly, Pancaldi states that a large key had been found in the cubiculum flanking the upper entrance, and that Fiorelli himself deduced that this could be the main key of the house, and that the room, with a window



Fig. 3. “Plan of a House at Pompeii. Excavated under the superintendence of Edward Falkener in 1847.” Falkener 1852, pages 34–35.

⁸ Pancaldi 1847, 12.



Fig. 4. Giuseppe Abbate's illustration of selected finds from the House of Marcus Lucretius in F. and F. Niccolini, *Le case e i monumenti di Pompei 1854*, pl. I.

opening onto the street, would then have belonged to the custodian of the house (i.e. R31).⁹ However, the three keys found in the house, one in iron (Cat. 181) and two in bronze (Cats. 159–160), were, according to the *PAH* and Falkener, all found on 12 August (a month later) in the servile quarters. This, unfortunately, raises even more doubts about the accuracy of the specified find-spots and the dates of the objects, in general.

Francesco Avellino also published an early report in *Bullettino archeologico napoletano*, without dwelling on the finds.¹⁰ The Neapolitan archaeologist Giulio Minervini started a description of the house in the *Bullettino dell'Istituto della corrispondenza archeologica*

in 1847, describing its architectural structures and paintings, but the report was interrupted by the break in the publication of the series. He then published the latter part of the account, including a list of the finds, in the lavishly illustrated volume of the Neapolitan architect brothers Fausto and Felice Niccolini, *Le case ed i monumenti di Pompei disegnati e descritti*, in 1854.¹¹ He states that he had examined the finds personally, “coi nostri proprii occhi”.¹² The accompanying drawings of eleven objects and eleven statues, in pl. I and pl. IV (Figs. 4–5), made by the official draftsman of the excavations of Pompeii, Giuseppe Abbate, have played a crucial role in recognizing some of the objects in the MANN collections. In the following year, substantially the same text by Minervini, with the same finds list, appeared again in the *nuova serie* of the *Bullettino Archeologico Napoletano* (1855, n.s., IV, No. 85).

⁹ In Minervini 1854, R31 is called a *cella ostiaria*.

¹⁰ Avellino 1848.

¹¹ Minervini 1854, 20–22.

¹² Minervini 1854, 19.

Fig. 5. Giuseppe Abbate's illustration of selected finds from the House of Marcus Lucretius in F. and F. Niccolini, *Le case e i monumenti di Pompei 1854*, pl. IV.

Minervini's description, divided according to the materials of the finds, is a secondary, interpretative source, containing misunderstandings copied from previous lists and sometimes duplicating objects – for example mentioning *both* the 'cup in rosso antico' and 'bust of Bacchus' of the same material – as well as other errors. For example, a part of terracotta finds list was included in the list of iron finds (Cat. 492–498), and a figure of Bes (I.2.10; Cat. 139) was listed both among the glass paste and terracotta objects. The list is not complete, omitting almost all vases, both in bronze and terracotta; however, it also includes items found in neighbouring houses, such as the terra sigillata plate with griffins, the candelabrum with ionic capital, and the terracotta bust of a boy, actually from IX 3, 2. However, it also contains independent observations for which he is the only source, such as the description of the decoration of the chariot elements, and some further details of the silvered bench found in triclinium R16.

The French artist and historian Ernest Breton, who visited Pompeii in 1854, published the first version of his illustrated guidebook *Pompeia. Décrite et dessinée*, including a description of the House of Marcus Lucretius, in the following year. An updated version of this work was published in 1870 (Fig. 6).¹³ His account is based on Falkener and Minervini, although he was very eclectic in his choices, copying the longer finds lists from Falkener of some rooms (such as prothyrum R1 and cubiculum R6) yet not reporting at all the finds from others (the atrium, triclinium R16, the garden area, the upper quarters, and the kitchen).



¹³ Breton 1855, 298–307, some relevant finds *passim*, and includes a short list of notable finds, 307. In the third edition in 1870, in particular, 396–397.

Finally, in his book *Descrizione di Pompei*, Giuseppe Fiorelli mentioned only select loose finds from the house: the discovery of the chariot, and the silvered bench.¹⁴

The early date of the discovery of the house doomed a large part of its numerous finds to be dispersed beyond recovery in the vast collections of the Museo Nazionale Archeologico of Naples (MANN), where the finds were taken immediately after their unearthing. The first attempt to identify and recontextualise them was made by Eugen Dwyer, in his valuable pioneering work *Pompeian Domestic Sculpture: A Study of Five Pompeian Houses and their Contents* (1982). The main purpose of his study was to publish the statuary assemblage of the house and situate it within its wider architectural, social, and material context; however, the work also contains a preliminary catalogue of the finds, locating many of them within the collections of the MANN. His catalogue is admirable in its prodigiously contextual interest, however it is to some degree eclectic, and does not pretend to be a complete catalogue.

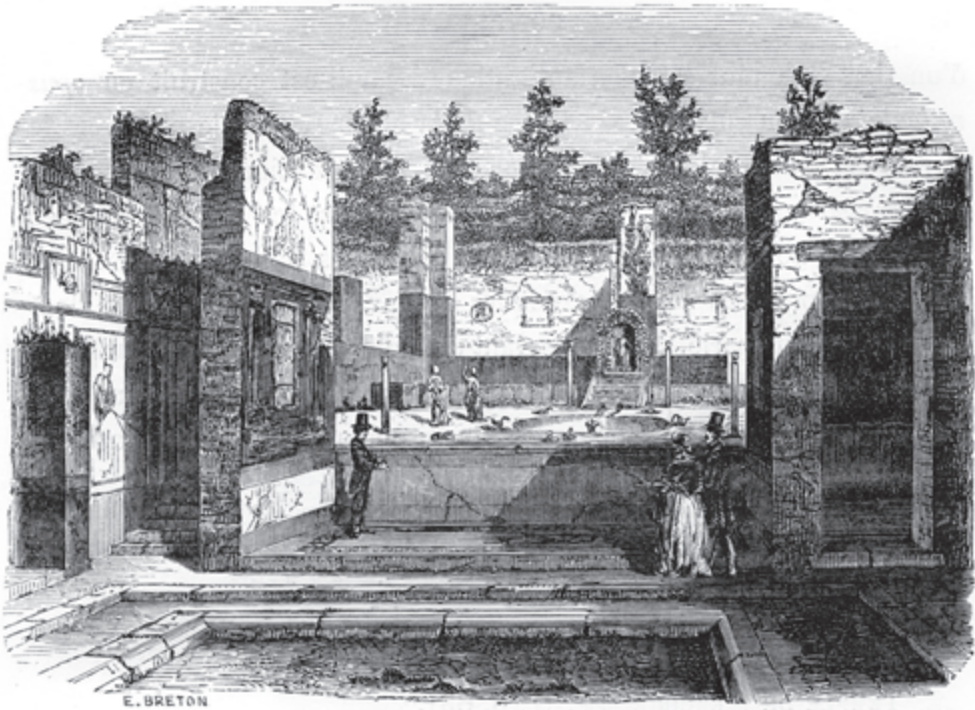

Fig. 6. Breton's early drawing shows visitors admiring the garden. The accuracy of the picture is a little problematic, because of the shape of the impluvium. The roof over the tablinum was not yet in place when the picture was drawn. Breton 1855, 187 and republished 1870, 241.

¹⁴ Fiorelli 1875, 392–394.

The second part of the story of the finds is, then, written in the inventories of the Museum of Naples. The complex history of the formation of the MANN collections and their multiple inventories has been summarized by several scholars.¹⁵ All of the objects, except for the statues, left Pompeii for the collections of the *Real Museo Borbonico* of Naples immediately after excavation, in two convoys, on 22 July and 4 October 1847. It was only some decades later that such convoys started to be regularly accompanied by shipping lists of the finds, called *Notamenti di scavo* or *Notamenti di spedizione*. In this case, however, such documents cannot be found in any archive. Dwyer does refer to *Notamenti* in his book, and none have been found in the present research, nor in an earlier enquiry by Lawrence Bliquez, who was searching for the medical instruments found in the House of Marcus Lucretius.¹⁶

The counterpart of these shipping lists was the inventory of objects arriving at the Naples museum, the *Registro Immissioni* in the collection of the Naples Museum. This document is extant for the years 1838–1851 (SANP 162), and contains notes on two convoys from the House of Marcus Lucretius. These are noted in the present Catalogue as *Reg. Im.* In the margins of the *Registro Immissioni*, and in some rare cases in the *Inventario San Giorgio* or the *Antichi Inventari*, later catalogue numbers were marked in pencil. However, these notes contain many errors, typically having to do with items having been confused with the previous or the following catalogue number. The *Inventario San Giorgio* was the current Museum inventory at the time of the arrival of the objects in 1847, having taken over from the older *Inventario Arditi*. The capillary inventory San Giorgio was compiled by the archaeologist and numismatist Domenico Spinelli, Principe di S. Giorgio, and was divided into volumes according to material type: *Terrecotte*, *Vetri Antichi*, *Bronzi minuti* (also containing iron and bone), *Marmi*, and *Oggetti preziosi* (containing the organic finds, *Commestibili*). The provenience of the objects was never indicated in these inventory books, and this is a crucial moment when the inventorial chain was broken, obscuring the connection between the objects and their place of origin.

Within the framework of the present project, the *Inventario San Giorgio* has been consulted starting with the objects with already known numbers. Objects from the same convoy often appear grouped together on the same pages, and many new inventory numbers have been discovered by their vicinity to items with recognizable features. The *Inventario San Giorgio* often adds much more precise descriptions and measurements of the objects, and is thus a precious source for the lost items. In some rare cases, the modern inventory number, referring to the so-called *Inventario Fiorelli* or *Inventario Generale*, still in use, was later written beside the entry for the object in pencil.¹⁷ This is the case for one copy of the *Vetri Antichi* catalogue, for instance, and in this way relatively many glass objects have been connected to their modern MANN numbers. In other cases, the pages listing objects by type in the *Inventario Fiorelli* have been consulted in search of a

¹⁵ Sampaolo 2005; Caputo – Tamburrelli 2007; Morisco 2012; Coralini 2018, 187–188.

¹⁶ Bliquez 1994.

¹⁷ Morisco 2012.

San Giorgio (Antichi Inventari) number, which in many cases was written at the end of an entry.

This inventory was also used in the early 1990s by Bliquez to locate the medical instruments found in the House of Marcus Lucretius.¹⁸ He could also consult a document called the *Registro oggetti provenienti dallo scavo reale di Pompeii* in the *Archivio Storico*: two volumes covering the years 1830–1851. In addition, he was also able to consult a document concerning the transfer of objects that arrived at the Museum on 22 July 1847, and were sorted out into the storerooms in 1853: *Inventario degli oggetti tolti dai due magazzini di deposito 1853–54*.

Unfortunately, even when it was possible to identify the modern MANN inventory number, in many cases it has not been possible to find the object. This is mainly due to the fact that many objects have lost their early inventory label tags, whether it was simply detached or was eaten by insects, and are currently identified solely as *S.N.* In some cases, it has been possible to recognize objects that lack a number, or that have a wrong inventory number, by consulting the Abbate's drawings in Niccolini brothers' volume (bracelet, glass cantharus, plane).¹⁹

The result of this work on the inventorial chain is:

- 503 objects/groups of objects were listed in *PAH*, or by Falkener and Minervini.
- ca. 40 finds were left in Pompeii (certainly 18 statues, a *puteal*, a round black stone, two transport amphorae and probably ca. 20 architectural elements, including fragments of paving, hydraulic tubes, column drums, a window grate, and other undefined elements). Of them, 16 statues and the black stone have modern Pompeii inventory numbers).
- Of the ca. 460 finds taken to MANN:
- 298 have been identified in the *Registro Immissioni*.
- 161 have been identified by their probable inv. San Giorgio number.
- 83 have been identified by their MANN inv. generale/Fiorelli number.
- 49 have been located at MANN.
- In total, 67 finds have been identified and located at the MANN and Pompeii collections, and published in this volume (18 statues, 6 *oscilla*, 10 terracotta statuettes, 10 glass vessels, 7 medical instruments, 4 bronze vessels, 2 lamps, 2 items of jewelry, 1 terracotta vessel, 1 plane, 1 money-box, 1 mirror, 1 lantern, 1 glass plate, 1 black stone, 1 architectural terracotta element).

¹⁸ Bliquez 1994, 13.

¹⁹ For similarities and differences in the study process for the finds from the Insula del Centenario, excavated some decades later, see Coralini 2018, 185–188.

Distribution Patterns

RIA BERG

All analyses of the distribution of objects in domestic space must start with their quantification and classification, both of which in this case present some basic problems. First, the quantity of the finds. In the present Appendix Catalogue (hereafter Cat.) there are 503 entries, with each separate item mentioned in historical inventories – whether a nail or a statue – having been counted as one find. Groups of objects have been counted together as one entry/unit, in cases where the inventories quantify them only as ‘numerous’, ‘several’, or ‘a group’, or they are clearly elements of, for example, one piece of furniture – thus, a group of ten bone hinges that must have been part of one cupboard (Cat. 19), or a group of seven silvered bronze discs, used to decorate a chest (Cat. 308), or a group of ten studs for door decoration (Cat. 125). The entries also include objects that were not part of the furnishings of the house, such as mosaic fragments (Cat. 47) or the skeletal remains of the two victims (Cat. 27, 141, 235). Different approaches have been adopted in other Pompeian projects – for example, counting the coins in groups, or also including some structural features of the house – and therefore numeric totals are necessarily always approximate.²⁰

The total number of ca. 500 objects/groups of objects found in the House of Marcus Lucretius is, by any method of accounting, high. Table 1 presents a comparison between the numbers of finds in other large Pompeian domus of roughly similar status category, and for which such data is readily available. The highest total, 1188 finds, comes from the large Casa del Menandro,²¹ but a high score is also achieved by the Casa di Iulius Polybius: 753 finds.²² The latter house was excavated in the 1970s according to modern standards, and if the fragments recovered are included then the number of finds would reach 2910, amply demonstrating how many more finds the other houses would presumably also have contained. We have reason to believe that during the middle years of the 19th century only whole and stamped/inscribed terracotta vases were preserved; not even all of the whole coarseware pottery vessels were recovered and listed, and glass shards were probably not collected. In contrast, metals, particularly bronze items, seem to have been collected *in toto*, including fragmentary elements.²³ However, excluding the missing

²⁰ For example, in the database of Penelope Allison, comprising the finds from thirty Pompeian atrium houses (2004 and <http://www.stoa.org/projects/ph/home>) some groups of objects appearing together in the inventories, and not located, have, in some cases, been given a single number. Both in the present House of Marcus Lucretius and Allison’s catalogue, some loose architectural fragments have also been counted, and Allison’s catalogue also considers fixed architectural features. On the problems of classification and quantification of ancient household inventories, see in part. Cahill 2001; 2010; Mimno 2011.

²¹ Allison 2006.

²² Castiglione Morelli 1996.

²³ Allison 2004, 30–33; Sigges 2002, 43, 46, 58–64.

House	Total finds	Major cluster of finds
Casa del Menandro	1188	82 in servile court 41 + 68 in room 43
Casa di Giulio Polibio	753	164 in peristyle CC
Casa del Fabbro	522	104 in atrium 3
Casa dell'Efebo	353	84 in tablinum 13
Casa di Paquio Proculo	279	55 in peristyle 9
Casa del Quadretti teatrali	275	148 in atrium b
Casa delle Nozze di Argento	247	33 in peristyle r
Casa del Sacello Iliaco	189	60 in atrium b
Casa della Venere in Bikini	183	92 in atrium 2
Casa dei Vettii	176	35 in peristyle m
Casa dell'Ara massima	171	38 tablinum F
Casa degli Amanti	154	67 peristyle 9
Casa di M. Lucretius Fronto	145	30 in atrium 2
Casa del Principe di Napoli	144	32 in atrium d
Casa dei Ceii	125	48 in atrium b
Casa di Trebius Valens	122	23 in cella u

Table 1. Total quantities of finds from a number of Pompeian atrium houses, and the place of their major cluster (Allison 2004, Sigges 2002).

pottery, a quantity of 150–200 objects seems to have been sufficient to run a well-to-do Pompeian domus.

Secondly, besides calculating the numbers of objects, all studies must confront the question of classification of finds by their material, morphology, and function. Here, there are two basic problems: 1) classifying objects with multiple functions, and 2) our differing levels of knowledge about the functions of the objects, some being well-known, others hypothetical or controversial. For example, lamps are easily recognizable objects that have one very clear function, and thus they normally always form a separate class in all classifications. In contrast, a 'pitcher' can have multiple and quite different functions and classification: it could be a table vessel for wine, a water jug for ablutions, a sacrificial *urceus* for religious ceremonies, or a simple kitchen or storage container. Placing it in the 'right' category of the above functional categories is quite impossible, and depends heavily on our present interpretations of the functioning of Roman objects.²⁴ Due to the differences between various classification systems, the functional categories from different works are not directly comparable, and have to be discussed on a case-by-case basis.²⁵

²⁴ Sigges 2002, 35.

²⁵ Allison has, in her database on Pompeian house contents, applied a two levels of classification to the ca. 6000 artifacts in her database. Firstly, the objects are divided into ten broad *artifact categories*: building material, coin, door, furniture, hole, sculpture, skeletal, utensil, vessel, and other. The more detailed categorization is made according to the 'type-function'; for example, 'food-preparation vessels', 'storage furniture', 'cloth production', and then 124 types of objects (coin, amphora

A non-interpretative classification can be made based on the material or the fabric of the artefact. Such a material division, used in older archaeological inventories, can seem artificial. However, it is quite indicative of the relative status of an assemblage, and arguably was a feature of which the original Pompeian house-owners would have been very much aware – and may thus even be considered an emic classification.

ML Finds by material:

Bronze 259 (51.5%), terracotta 82 (16.3%), glass 43 (8.5%), iron 43 (8.5%), marble 34 (6.8%), bone organic 20, stone 6, gilded stucco fragments 6, lead 3, gold 1, silver 1, terracotta/stucco 1, lime (heap) 1, mosaic (group of fragments) 1, blue pigment 1, unknown 1.

In the present book, the main classification starts from broad, non-interpretative categories: I Objects of art (plastic figures) (42), II Vessel/container (137), III Instrument/tool/utensil (135), IV Fixture (162), and V Other (27), which comprises items that were not part of the original furnishings of the house (architectural fragments, bones, etc.).

The secondary division, then, is made by applying functional criteria, opting for as neutral a labelling as possible: for example, 'pouring liquid' for pitchers and jugs. This also adds elements of interpretation, as some categories can be defined more in detail – for example lamp: for lighting; inkwell: for writing; and surgical knife: for medical operations.

I Objects of art (42 = 8.34 %)

Marble statues 22 = 4.37%. Oscilla 6 = 1.19%. Terracotta figurines 14 = 2.78%.

II Vessels (137 = 27.24%)

Consumption, culinary 28 = 5.57% (cups and mugs 24, plates 2, spoons 2). Pouring liquids 25 = 4.97% (jugs, dippers). Medical/cosmetic vessels 24 = 4.77% (unguent bottles 22, aryballos 1, pyxis 1). Storage 14 = 2.78% (amphorae, urcei, large bottles, bowls). Cooking/storage 9 = 1.79% (jars, lids). Cooking 6 = 1.19% (cauldrons). Cooking/heating 1 = 0.20% (water-boiler). Containing liquids 4 = 0.80% (basin). Food preparation 2 = 0.40% (mortar 1, pestle 1). Uncertain 24 = 4.77%.

III Instruments (135 = 27.05%)

Economic 42 = 8.35% (coins 40, money-box 2). Medical/cosmetic 32 = 6.36%. Lighting 19 = 3.78% (lamps 12, candelabra elements 5, lantern elements 2). Tools 16 = 3.18% (carpentry 7, agricultural 7, iron knives 2). Weighing 6 = 1.19% (scales,

etc.). In the case of unknown purpose, the category 'diverse vessel function' is utilized, and in the case of the multi-functional objects a single function has been chosen.

weights). Entertainment 5 = 1.19% (tesserae lusoriae 4, dice 1). (Personal) ornaments 4 = 0.80% (jewellery 2, accessory 1, glass disc 1). Textile work 4 = 0.80% (spindles 2, loom weights 2). Terracotta rings (a group of, unknown function) 2 = 0.40%. Writing 2 = 0.40% (inkstands). Other, Fire-shovel 1 = 0.20%. Bell 1 = 0.20%. Hook 1 = 0.20%.

IV Fixtures (162 = 32.00%)

Closure 83 = 16.50% (lock elements 33, keys 3, hinges or groups of hinges/bolts 2). Transport 10 = 1.99% (chariot, horse harness 1). Other furniture fittings 63 = 12.52% (nails 30). Pieces of furniture 5 = 0.99% (bench 1, bed 1, table 1, altar 2).

V Other (27 = 5.37%)

Architectural 18=3.58% (elements of roofing 2, ceiling 6, paving 1, hydraulic 4, column drums 2, revetment 1, window 2). Organic/non-defined 9=1.79%.

These classifications and quantities can be compared most readily with the tabulations of objects made by Bernard Sigges for the five Pompeian domus that he studied, working extensively with their material contents.²⁶ In Table 2, the House of Marcus Lucretius finds are counted according to the categories of Sigges, conformed slightly differently. The finds from the House of Marcus Lucretius were as or more abundant than Sigges' domus in all

	Casa dei Cei	Casa di Paquius Proculus	Casa delle Nozze Argento	Casa del Principe di Napoli	Casa dell' Ara Massima	Casa di M. Lucretius
Vessels	15	49	41	77	35	137
Containers	10	20	23	7	2	
Tools/instruments	16	29	19	18 + 54	12+ 120	68*
Lighting	13	13	10	7	32	19
Furniture	53	127	59	15	66	161 (fixtures)
Sculpture	5	2	10	3	3	42
Dress/jewel	9	21	12 + 30	12	9 + 103	4
Gaming pieces	-	119	234	-	-	6
Coins	3	8	42	3	12	40
Gems	-	-	1	-	-	-
Skeletons	1	11		2	-	1 + cranium
TOTAL	125	398	508	198	394Ca	477 (+ other)

Table 2. The finds from the houses studied by Sigges (2002) and from the House of Marcus Lucretius. *besides lamps, jewelry, coins

²⁶ Sigges 2002.

categories, with the exception of accessories for dress/jewelry, with only four items.

Further comparisons will be made in the following chapters dedicated to different find groups. The individual chapters are divided by the primary or secondary classifications, according to the type and nature of the objects discussed.²⁷

Over the recent decades, the contextual study of objects in domestic space has been an active field of study in Vesuvian archaeology.²⁸ There have been high hopes that Pompeian house-floor assemblages may provide information on the social practices of Roman households and, in particular, on the specific uses of different types of rooms.²⁹ As stated by Andrew Wallace-Hadrill already in 1994, “In any survey of the social and economic aspects of houses in Pompeii and Herculaneum, study of the finds should play a crucial, perhaps *the* crucial, part.”³⁰

Penelope Allison has made the comparison of room-types and their associated artifact groups the focus of two large studies: an analysis of the finds from thirty Pompeian atrium houses (2004), and the finds from the Insula of Menander (2006). The results of her studies focus on the factors that have altered artefact inventories, and the placement of objects in Pompeian houses. Allison has underlined, in particular, how the looting and hoarding of valuable items affected the city after it was hit by a series of earthquakes starting in AD 62, leaving some houses abandoned and others occupied by temporary inhabitants, even squatters.³¹ Many other scholars have discussed this series of premonitory earthquakes and their destabilizing effects on Pompeii.³² Certainly, various construction works were going on in Pompeian houses, and the presence of workers must have affected the disposition of mobile items in many ways.³³ Further dispersal of household goods (especially jewels, coins, silver vessels, lamps) must have been caused by emergency salvaging following the AD 79 eruption.³⁴ The spoliation of precious objects and materials from the houses after the eruption through tunnelling has been an activity much more wide-spread in time and place than has been previously understood.³⁵

The House of Marcus Lucretius was surely affected by most of the above-mentioned phenomena. The house had probably been much damaged in the powerful AD 62 earth-

²⁷ On the principles of classification of artefact categories, Sigges 2002, 553–554.

²⁸ Berry 1997 a, 1997 b; Sigges 2002; Allison 2004, 2006; Coralini 2018.

²⁹ Nevett 1997, 281–286; 1999, 1; George 1997, 301; Allison 1997. For the developments in the research on house floor assemblages, in general, Nevett 1997, 282–283.

³⁰ Wallace-Hadrill 1994, 87.

³¹ Allison 2004, 192–196. Refuting, in particular, the so-called ‘Pompeii premise’, stating that the Vesuvian sites would be ‘frozen in time’ and immune to depositional processes forming normal archaeological contexts, Binford 1981; Schiffer 1985; LaMotta – Schiffer 1999; Allison 2004, 4; 2006, 15. See also Berry 1997b, 103.

³² Maiuri 1942; Adam 1986.

³³ Objects and furniture must have been moved away from the rooms being repaired, and locked up more carefully than normally. On the seismic activity prior to the 79 eruption and its effects, see Varone 1995; 2005; Fröhlich, Jacobelli 1995; Allison 2004, 17–19. For the presence of construction materials in houses, Allison 2004, 187–192; 2006, 404; Anderson 2011; the state of houses, Berry 1997 a, 82; 1997 b, 104; Sigges 2002, 34–35.

³⁴ D’Ambrosio, De Carolis, Guzzo 2003, 75–76; Allison 2004, 19–21; 182–186;

³⁵ Allison 2004, 21–24; 179–182; Sigges 2002, 74–79.

quake, but was reconstructed in a novel shape, including a large upper floor sustained on heavy brick piers, opening onto balconies around the small peristyle garden.³⁶ The house was, however, undoubtedly re-inhabited and functional at the moment of the eruption, as the kitchen was richly equipped with vessels, and there were numerous objects, including foodstuffs and valuables, located all over the house.³⁷ Damage may also have been caused by the tremors that accompanied the last days of Pompeii, even as construction and repair was underway: this is revealed, in particular, by a heap of lime situated in R26 (Cat. 351), and fragments of dismantled Ionic columns in tufa, found in R26 and R31 (Cat. 352, 408), as well as in the fauces of IX 3, 25. The presence of numerous carpenter's tools was also possibly due to this (as discussed in Chapter III.3). There can be no direct evidence of the salvaging of materials during the eruption, but indirect evidence consists of the fact that in spite of the richness of the finds in general, almost all precious materials – silver, gems, gold – were missing, except for one small gold ring and some bronze coins. As for tunnelling, and the spoliation of materials after the eruption, while there is no direct mention in the excavation reports, there are hints that this phenomenon has also touched the house. A robber hole was noticed by Falkener in cubiculum R4, and the missing marbles of the atrium R2 were attributed by Bechi to the action of spoliation after the eruption, rather than on-going construction work, although he did not further explain his interpretation.³⁸

These invasive factors have certainly contributed to a sense of an illogical mixture of artefacts in Pompeian household inventories, and a consequent sense of pessimism about the possibilities to read the use of those domestic spaces through their objects. However, many scholars have also brought forth contrary evidence of the continued liveliness and orderliness of Pompeian households. Michael Anderson has, for example, examined the placement of bulky construction materials in Pompeian houses, observing that they were placed away from the central visual axes, evincing that these houses had remained inhabited and functioning despite the renovation works.³⁹ This was also the case for the House of Marcus Lucretius; even if the rear part of the house was clearly under (re)construction, the front part seems to have been functioning normally.

Some scholars have proposed that the apparently illogical grouping and placing of objects may actually be due to the normal living practices of Roman households. Joan Berry has thoroughly studied the finds of three insulae of Region I and published a series of case studies examining the contents of single houses, underlining their great importance in understanding the status and organization of Pompeian houses.⁴⁰ She has rightly put much emphasis on the flexible nature of Roman domestic activities: the movable objects and furniture could transform a space and adapt it to different uses, depending on the

³⁶ Dwyer 1980, 21.

³⁷ On the criteria for identifying a house as inhabited, see Allison 2004, 192–195; 2006, 401–402, including the presence of skeletal remains and kitchen utensils.

³⁸ Bechi 1852, 3: “forse levata via con tante altre cose da questa sepolta città dagli antichi istessi dopo l'eruzione”.

³⁹ Anderson 2011.

⁴⁰ Berry 1997a, 194–195.

time of day, season etc., and resulting in mixed room contents.⁴¹ As objects refer to small-scale, temporary activities and the short-term use of space, the artefact assemblages may well differ from the ‘official’ designation of the rooms suggested by wall-decorations and fixtures.⁴² According to Berry, rather than searching for destinations fixed permanently to certain spaces, the activities of a house should be examined through clusters of activity-related objects.⁴³

Bernhard Sigges has examined and compared the contents of five Pompeian *domus*, examining the use of their rooms primarily on the basis of the finds.⁴⁴ He has underlined how such a study conveys a more nuanced, flexible, and ‘colourful’ image of the household, one not solely based on the structural and iconographic ‘official propaganda’ of its constructor, the *dominus*. Sigges has also noted how, if the distribution of finds does not follow our modern expectations, this could be due to numerous casual and temporary factors, but also to our insufficient knowledge of the ordinary working of Roman houses: “Dies sollte jedoch keineswegs als Hinweis auf eine generelle Störung des Befundes verstanden werden.”⁴⁵

Indeed, a wide scholarly consensus now holds that even though the individual spaces of the Roman house may have had a primary function – the atrium for receiving the *salutationes*, the triclinium for banqueting, the cubiculum for sleeping and other private activities – they were substantially multifunctional.⁴⁶ The finds recovered from these spaces are rarely directly related to these primary functions of the rooms, for which information can best be found through architectural, pictorial, and literary sources.⁴⁷

Similar results were reached in my earlier research on the assemblages of *mundus muliebris* in Pompeian houses: not much could be ascertained about the specific rooms where toiletry items were used.⁴⁸ In the large majority of cases, female toiletries were kept in storage areas, not in rooms that could conceivably have been used as boudoirs for intimate grooming practices. The clustering of the valuable utensils of a household in a few rooms of the house could be due to ‘safekeeping’ being the leading principle of placing objects in the house. The Roman house differed radically in two aspects from the modern

⁴¹ Berry 1997a, 194; 1997b.

⁴² Berry 2016. See also, Nevett 2010, 97–101.

⁴³ Berry 1997a, 193–194.

⁴⁴ Sigges 2002.

⁴⁵ Sigges 2002, 493–494: Pompeian houses rarely have ‘exemplary’ find contexts, where the furnishings of a room follow the ‘modern expectations’, p. 557: “Der Mechanismus, mit dem derartige Befunde von Allison als Ausdruck einer ‘Störung’, eines ‘Niedergangs’ im untersuchten Haus umschrieben werden, verdeckt das elementare Verständnis, daß eben diese Abweichungen vom erwarteten ‘Normalzustand’ einen Hinweis auf die nicht regelgerechten, sondern konkreten Lebensumstände darstellen.”

⁴⁶ Nevett 1997, 292; Winsor Leach 1997, 59; Berry 1997 a; Sigges 2002, 35, 493; Cova 2010, 388; Dickmann 2011, 210; Emmerling 2011, 219.

⁴⁷ On the great importance of using all types of source materials together, Dunbabin 1995, 387. For the primary functions and Latin nominations of the spaces of domus, see Winsor Leach 1997, 52–57, 62–66, 68. For cubacula, see Riggsby 1997, Nissin 2009. For alae, see Cova 2010, for peristyles, Simelius 2015.

⁴⁸ Berg 2010.

Room Type	Finds in Room Types	Average of Finds in Room Types
1 peristyle R18 (many objects fallen from UF)	50	50.0
2 atria R2 (29), R29 (41)	70	35.0
4 servile rooms	64	16.0
8 cubacula R3/4 (48), R5 (28), R6 (10), R7 (3), R23 (2), R30 (5), R31 (6), R32 (13)	115	14.3
7 passages R1 (7), R19/20 (19), R26 (2), R28 (4), R33 (5), R34 (13)	50	7.1
2 triclinia R16 (8), R25 (8)	16	8.0
2 alae R8 (9), R9/10 (7)	16	8.0
tablinum R15 (6)	6	6.0
upper floors R18UF (36), R2UF (11), R15UF (3), R7UF (2)	52	
Unknown location	64	
Total	503	

Table 3. *The distribution of finds in room types in the House of Marcus Lucretius.*

one, creating a need to keep objects locked up: the presence of (non-trusted) slaves, in all of its spaces, and the much greater value attributed to even simple everyday utensils.⁴⁹ The large number of locks among the finds from Pompeian houses, 33 in the House of Marcus Lucretius, is a further indication in this direction.⁵⁰

In a significant number of Pompeian houses the finds are notably clustered, and there is one primary storage area that stands above the others in terms of the quantity and quality of the finds.⁵¹ This is typically a lockable cupboard placed in the atrium or peristyle (or in some other space of passage), or a closable cubiculum. Examining the houses studied by Allison and Sigges, the primacy of atria, followed by peristyles, as household storage spaces was very clearly indicated (Table 1).⁵²

In the House of Marcus Lucretius a similar pattern can be discerned (Table 3). The rooms with the highest numbers of finds are indeed the two atria and the peristyle garden. Whilst the peristyle material, in this case, seemed (according to Falkener and the *PAH*) to be mostly fallen from upstairs, rather than being actually stored in the surrounding corridors, the main atrium R2 (with 29 items) and the upper atrium R29 (with 41 items)

⁴⁹ Berg 2014.

⁵⁰ On the importance of storage contexts in Pompeii, see also Neveit 2010, 103.

⁵¹ Berg 2010, 2014, 2016. For the implications of the presence of slaves in the house, Joshel 2013, 101, 109 (on theft), 112 and passim.

⁵² Sigges 2002, 628; Allison 2004, 164–166. Also, in Berg 2010, the find places of toiletry contexts with other valuables were found to be in atria in: Casa del Bell' Impluvio (I 9, 1), Casa di Venere in Bikini (I 11, 6.7), Casa Imperiale (I 11 17), Casa di Ti. Crassius Crescens (I 13, 1), Casa di Elvio Severo (I 13, 2), Casa I 16, 5, Casa V 3, 10, Casa V 15, 23, or in peristyles: Casa di Paquio Proculo, Casa dei Quattro Stili, Casa di Mestrius Maximus, Casa di Maio Castricio (VII 16, 17).

seem to have been central storage areas of the house. Both contained traces of cupboards: a collection of bone hinges in R2 and the two masonry recesses in R29. Another cupboard, for storing utilitarian vessels of terracotta and glass, seems to have been placed in another transitional space, the passage R19/20, functioning as an ambulatory for the peristyle garden. Obviously, these connective rooms were accessible even when the single cubicles and triclinia were closed, and were the most reachable places in the mobility chart of the house.

Although the cubicles as a room type contained a high number of finds (115 items), when the figure is divided by the number of such rooms (8), a considerably lower average (14.3 items) emerges. There are, in fact, significant differences between the quantity and quality of assemblages contained in various individual cubicles.

The first room to the right after the fauces (R4), one of the four similar cubicles opening onto the atrium, may have been the primary storage area for the valuables of the house. Unfortunately, the 48 finds that came to light on the day of its excavation were mixed up with the finds from the small and undecorated under-stairs *cella ostiaria* R3; a doubt will thus always remain about whether they were stored together, or divided between the two rooms. Similar small, rustic storage spaces, such as R3, sometimes with shelving, tend to have been found empty in Pompeii: for their role, the storage of perishable stuffs can be generally assumed (sacks with foodstuffs, textiles, bedcovers, etc.).⁵³ The context from R4 included the only piece of gold jewellery from the house, a coin-bank, a series of important bronzes, a finer relief-decorated glass service, and terra sigillata vessels; some iron tools were conserved here as well.⁵⁴ The cubiculum R4 may arguably have been used for storing objects that were more precious, but also needed a warmer storage space than the atrium, which was subject to all the oscillations of outside temperature. A part of the glass service was found in the opposing cubiculum R6, which may also have been used as a minor storage space.

Considering such phenomena from a wider Pompeian perspective, there is a series of houses in which the main storage room, containing precious items mixed with bulky storage, was situated in a small and modestly decorated room of cubiculum type, placed near the fauces.⁵⁵ Such a space might even be the room of the *atriensis* or *promus*, who would live in the room together with the most precious objects that were his responsibility to safeguard, as has been suggested in the case of the procurator's room in the House of the Menander.⁵⁶ In the house of the Menander, the silver service of 118 pieces was, however, not safeguarded in this room, but hoarded in the basement.

⁵³ For this phenomenon, see Nevett 2010, 104–105.

⁵⁴ On the general tendency of storage spaces tending to accumulate very mixed assortments of possessions, see Schiffer 1996, 68–69.

⁵⁵ Berg 2010, 302: Of the deposit contexts containing toiletries, the largest number were in atrium houses, 11 were found in 'cubicles' flanking or near the fauces; 9 in cupboards of the atrium, 6 in cupboard in peristyle. Among the contexts of toiletries with valuables are Casa I 9, 8, Casa del Fabbro, Casa I 11, 12, Casa I 11, 16, Casa I 14, 8.9, Casa V 3, 11, Casa del Flamen (V 4, 3), Casa di Vedius Vestalis (V 15, 12), Casa di Aurunculeius Secundio (VI 16 32). See also Berg 2014 and 2018.

⁵⁶ Opdenhoff 2011. For slave rooms, in general, see Joshel 2013, 105.

Another important observation can be made on the basis of the find distribution map (App. 1, Fig. 1) of the House of Marcus Lucretius. The finds score is particularly low in rooms of the public display areas of the house: *tablinum*, *triclinia*, *alae*. Such areas can be identified through their wall decoration, which was the most elaborate in the house (including large, central, mythological subjects, architectural intervals between the panels, secondary figure paintings).⁵⁷ Other examples of empty public display spaces are numerous in Pompeii. To cite one example, in the House of A. Trebius Valens the distribution of finds and elaborate wall paintings form two distribution maps in complementary opposition: the most public rooms – *triclinium p*, *tablinum n* and *oecus z* – were almost devoid of finds, while the finds were in fact concentrated in the least decorated rooms, in particular the *cella ostiaria u*.⁵⁸ According to the logic of safekeeping, the most valuable objects of the house were most likely used in the largest and most decorated rooms, but were unlikely to have been stored there when not in use.

In the House of Marcus Lucretius, a similar opposition can be clearly observed, as the rooms gravitating around the *fauces*, including the atrium court, seem to be designated for storage, while the zone gravitating around the *tablinum/triclinium*, suited to public display, were kept relatively clear of objects. The most lavishly decorated room, *triclinium R16*, only contained two utensils: a dice (Cat. 232) and a terracotta cup (Cat. 233), besides elements of closure and fixture.

Antonella Coralini, in the recent publication of all the old finds from the *Insula del Centenario*, also observes that the finds from this city block are strongly concentrated in certain zones and rooms.⁵⁹ Here, this may also be caused by a tendency to safeguard personal possessions by concentrating them in a few closable spaces. The main house of the *insula*, the House of the Centenary, with its total of 228 finds, seems to have been somewhat ‘downgraded’ from a fully equipped elite *domus*. Observing the distribution of recorded finds in the area of the major atrium (2), the finds are concentrated in the cupboards at the atrium corner near the *fauces* (45 items), and the first *cubicula* at the two sides of the entrance (b: 4, l: 7 items), and the *cubiculum* east of the *fauces* (a: 6 items).⁶⁰ In contrast, the four rooms on the *tablinum* side – the further *cubicula*, *alae*, and *oeci* flanking the *tablinum* – were empty, although the *tablinum* itself contained 18 items.⁶¹

A similar tendency can also be observed in the House of the Menander, even if its main atrium was undergoing construction work at the moment of the eruption. Here, as well, the finds from the atrium complex were distributed predominantly around the

⁵⁷ Tammisto – Kuivalainen 2008, 76–78, fig. 7.4. For the ambivalent role of the *alae*, see Elisabetta Cova’s (2013) research on the role of the *alae* as flexibly adaptable spaces, used both for storage and public display.

⁵⁸ Berg 2014, Allison 2004, 92, 181–182. For comparison, a summary of finds from the *oeci*, *tablinia*, and *triclinia* of the five houses studied is presented in the form of a synoptic table by Sigges 2002, 632.

⁵⁹ Coralini 2018, 167.

⁶⁰ Coralini 2018, 237, 283.

⁶¹ Coralini 2018, 283–297. Nine objects were recovered from the *tablinum*, but only one utensil, the others being parts of locks and statue bases. Likewise, the *oeci* and *triclinia* opening onto the *peristyle* contained only a few items or were completely void.

fauces: the three rooms flanking the entrance contained the richest finds.⁶² The cubacula of the rear zone near tablinum (rooms 6–7), in contrast, were empty, and ala 4 contained only two items. The tablinum contained, besides the remains of two *klinai* and closures, only one terracotta cup and two loom-weights.⁶³ In the area of the peristyle, numerous objects (66 pieces in all) were stored in its *ambulacra*, but the representative oeci 11 and 12 had only a few objects, and in particular the grand triclinium 18, besides elements of closures and furniture, only contained one glass jar.⁶⁴

Activity-related clusters of artefacts, found outside of the storage areas, can therefore be considered as the most potential indicators of on-going activities.⁶⁵ In the case of the House of Marcus Lucretius, cubiculum R5 is particularly interesting, as a large medical *instrumentarium* was found there, with no other non-pertaining items other than a candelabrum, so the area was apparently not used for mixed storage. This room may plausibly have been occupied by a doctor, a resident member of the household (perhaps a freedman), or a patient, at the moment of the eruption. A bronze ink-well that came from the cubiculum (Cat. 119) may also belong to the set.

Another room, cubiculum R32 in the rear part of the house, is interesting for a possible gendered reading of the objects. The most cohesive group of female toiletries in the house came to light in this room: four cosmetic probes, a mirror, a bronze pyxis containing sulphur, and a bronze needle, possibly together with the remnants of a bed (Cat. 409–421). Otherwise, objects possibly related to women were scarce and sporadic: a bone spindle in the servile quarters R11–14 (Cat. 213), another mirror and a group of unguentaria in the kitchen area, but probably deriving from upstairs (Cat. 166, 176–178, 186, 192). Only four items can be connected with textile work. These include, besides the spindle (Cat. 213) and the bronze needle (Cat. 420) mentioned above, only two loom weights (Cat. 404, 493), one from cubiculum R31. The loom weights could be residual, perhaps used for some other makeshift purpose, as they were not functional as single units.

The kitchen/servile area was also richly equipped with vases, vessels, and other utensils, although the rapidity of the excavations in that area renders the identification and quantifications of the finds particularly difficult. The vessels – which may have been in use at the moment of the eruption – included a marble mortar and pestle (Cat. 156–157), and in bronze, two boilers (Cat. 215), a strainer (II.1.4, Cat. 185), and a funnel (Cat. 187), and other smaller vases (Cat. 162, 165). Among the terracotta cooking vessels, a pan, ‘tegame’ (Cat. 203) and terracotta mugs (Cat. 202, 179–180) were present.

⁶² Allison 2006, 56–66. 19 items were found in atrium 2; in the rooms flanking the fauces: 12 in room 1, 10 in room 3, 10 in room 5. Emmerling 2011, 220. See Dickmann 2011, 209, fig. 2, for the mapping of residential vs. household management spaces.

⁶³ Allison 2006, 63–66; Emmerling 2011, 219.

⁶⁴ Allison 2006, 67–81; Deppmeyer 2011, 225, 230.

⁶⁵ On activity patterns in Greek houses, see Cahill 2010, 477.

Foodstuffs were found as a separate cluster of three *urcei* for garum, an amphora for garum, an amphora for Greek wine, and two dishes of olives in the upper triclinium R25 (see chapter II.3 on terracotta vessels). This seems to be bulk storage, without any connection to banqueting, which must have been the primary purpose of this large hall decorated with wall-paintings and mosaics, and open to the garden. As the centre of the pavement, the mosaic *emblema* was missing, and it seems that this room was used as a temporary storage place while construction works were going on.⁶⁶

Interestingly, the three most valuable vessels of the House of Marcus Lucretius, the two large silvered, relief-decorated bronze amphorae and the silvered bronze patera, were found alone and separated between the left ala and the garden. It seems likely that they would not have been there for practical use (i.e. pouring water during a banquet) at the moment of the eruption. One hypothesis might be that the twin amphorae and the patera may have been symmetrically set on display in the atrium or on the tablinum marble table at the moment of the eruption. This would have replicated the ancient custom recorded by Varro (*ling.* 5.125) of setting *aenea vasa* on show in the atrium.⁶⁷

Furniture form a distinct case among the *mobilier* of the house, being somewhat less movable and less liable to theft, and thus always more likely to have been left in their place of use.⁶⁸ The most numerous elements of furniture were found in the public display zone of the house, between the alae and the main triclinium. One of the most luxurious and showy items of the house must have been the long bench on eight silvered legs, with traces of decorated cushions, which was found in the triclinium R16 (Cat. 228). Other traces of display furniture were found in the area between the left ala and the tablinum/garden. A figurative bronze furniture ornament, perhaps in the form of Minerva, was found in the same area, possibly in ala R9 (Cat. 149); a bronze furniture element, a cylindrical ornament, with carbonized wood inside (Cat. 140), was found in ala R8. A set of seven partly joined silvered bronze bosses found between the tablinum and garden was interpreted by the excavators as the remains of a large chest, possibly the *arca*, the safe-box of the house (Cat. 308). Furniture elements are discussed in more detail in the chapter dedicated to the closures and fixtures.

As for objects connected to cult and religion, the imposing painting- and relief-decorated lararium in the S–W corner of the atrium was found empty, and no *Lares* figures or other bronze statuettes were found in the house. Such statuettes may likely have been among the salvaged objects missing from the house.⁶⁹ A small terracotta altar (Cat. 273), complete with a statuette of Minerva, was found in the ala R9. A small stone altar (Cat.

⁶⁶ Falkener 1852, 78. Falkener suggested that the nearest cubiculum, the unadorned R23, would have served as an apotheca triclinii.

⁶⁷ Deppmeyer 2011, 228.

⁶⁸ On the mobility of the furniture in Pompeian houses, Berg 2008; Deppmeyer 2011, 228–233.

⁶⁹ Even though there was some confusion with a rich collection of bronze statuettes that came from unit IX 3, 5; many authors have erroneously collocated these in the House of Marcus Lucretius lararium. Doubts about their place of discovery were expressed immediately after the excavation, see Falkener 1852, 88; Minervini 1854, 19–20: “...cinque statuette, le quali non ben si conosce d’onde siano state tratte”; 1855, 81–82.

184) was found in the servile quarters, and may have been connected to cultic activities, or the worship of the Lares at the domestic hearth. The group of eight terracotta statuettes found in the kitchen area, including a Venus figure (see Pietilä-Castrén in this volume, Cat. 194–200, 209), were otherwise of mostly non-religious subjects, and may have possibly fallen from upstairs. The garden R18, besides the numerous marble sculptures with Dionysiac imagery (see Kuivalainen in this volume), also presented some allusions to Egyptian cults in the form of two ibis-birds. A terracotta statuette of Bes, the grotesque Egyptian protector of children and family, was catalogued among the finds from ala 8 (I.2.10, Cat. 139, Pietilä-Castrén in this volume),⁷⁰ together with a piece of compluvium decoration, and might thus also rather come from the atrium, although more plausibly originally belonging to the garden setting.

Finally, two female statuettes, perhaps divinities, of terracotta/stucco (I.2.1, Cat. 195; I.2.3, Cat. 219) were found in or around the tablinum, and were probably parts of the applied decoration of its ceiling or upper walls. They should be considered together with the numerous sets of gilded and painted stucco fragments found in the House of Marcus Lucretius, as belonging to its highly decorated tablinum ceiling (Cat. 18, 26, 46, 220, 222–223). These were collected mostly in the atrium R2, and tablinum R15 (Cat. 18, 26, 46, 220, 222–223). Bechi already mentioned the numerous colourful fragments of the ceiling: “Questo tablino aveva il lacunare o il soffitto lavorato a cassettoni con rosoni indorati, i cui frammenti si sono rinvenuti in gran copia nelle macerie dello scavo”.⁷¹ According to Falkener, similar fragments were also found in ala R8, and the triclinium R16. The latter are described as being in different in style, and are interpreted by Falkener as evidence that also the room above the triclinium had an ornamented ceiling. Falkener writes about the ceiling in the following way (p. 66–67):

“The ceiling of atrium was of wood, of this we could expect no traces: but the apartments opening onto it, as the tablinum, exhedra, and the alae, had stucco ceilings. All these were magnificently adorned. The most gorgeous, perhaps, was that of the tablinum. It consisted of a large circle in a square panel, boldly moulded, and enriched with stucco ornament, with ultramarine, vermilion, and purple colouring, together with a profusion of gilding. I put the pieces together at the request of the government artist, Sigr. Abate, to enable him to make a restoration of it: and was promised, in return, a copy of the drawing, not being allowed to take one myself. But the drawing was never given me, and on my revisiting the city two years afterwards, the fragments were deposited in the magazine of the museum, where they will probably remain for the present generation; but should they again be brought to light, no one will know from what site they were originally procured.”

⁷⁰ See also Pietilä-Castrén 2008.

⁷¹ Bechi 1852, 8.

In fact, the fragments arrived at the Naples Museum on 22 July 1847, and were, according to the *Inventario San Giorgio*, collocated in a specially made wooden chest with an iron grating. At present, it has not been possible to find them in the Museum.

Having survived all their decimations, Pompeian houses still offer unique and plentiful opportunities for the study of lived ancient artefact assemblages. The recent publication of the finds of the original excavations of the Insula del Centenario (the excavation was started in 1879) has also much valorized old, partially conserved finds as a neglected but important source of information. The editor of the volume, Antonella Coralini, in her 'Alibi Archaeologies' project, puts the study of old excavation documentation in the archives and the Museum storerooms at the fore: "seppur ridotto e contaminato il loro potenziale informativo merita di essere valorizzato nella sua specificità".⁷²

In general, objects form a dynamic interface between architectonic spaces and the activities of their inhabitants. In Roman houses, utensils were on the move: rather than being assigned fixed locations, they had trajectories, transposing them between several *etappes* in different rooms: use, cleaning, and storage. To understand the distribution patterns of objects in space, it is of primary importance to first understand the mechanics of their movements, under normal circumstances, between areas of activity and storage. Furthermore, the evidence from the House of Marcus Lucretius and other comparable Pompeian domus suggests that, besides studying the contents of single room types and clusters of activity-related objects, it may also be useful to study larger activity zones, that seem to have two principal groupings: 1. fauces zone and the front part of the atrium area (storage); 2. tablinum and triclinium zone at the posterior part of the atrium (representative use, little or no storage). Studying these zones, rather than single room-types, is crucial to understand the underlying principles of Roman domestic objects management.

⁷² Coralini 2018, 163 et passim.

I WORKS OF ART

I.1 Marble Sculpture

ILKKA KUIVALAINEN

Introduction

The sculptures discovered in Pompeian houses were mainly located in their gardens, although many were also recovered from atria.¹ Several gardens had other elements that might be classified as display and entertainment fixtures, although they may also have been multifunctional.² Most of the gardens are small, but the owners evidently wanted to imitate the gardens of larger villas; sculpture played an important part in their architectural role. The majority of this sculpture consisted of modest forms, such as herms and oscilla, and the statues were made on a smaller scale. This habit of decorating gardens developed at the end of the Republic, and continued in nearly the same fashion during the Empire. Many statues were copies or free imitations of Greek originals, which were produced in large numbers.³ There was also local marble production in Pompeii, in the Casa dello Scultore (VIII 7,24) at least, and possibly in several other places (VI 2,4, VII 11,3, and I 10,6 and 7).⁴ Marcus Lucretius' garden was relatively small, at 47.58 square metres,⁵ but he used it to display his evidently broad interests, which are shown by the wide variety of deities depicted in the wall paintings, sculptures, and figurines recovered from his house. The overall artistic scheme is clearly Dionysiac or Bacchic.⁶ Most of the marble sculptures were discovered in the peristyle garden (Room 18), which was small compared to other gardens with similar programs of extensive sculptural decoration.⁷ In Marcus Lucretius' garden, the free-standing sculpture stood around a circular basin, and oscilla were hung in the peristyle intercolumniations, as was customary. There was another fountain in a

¹ Döhl 1976 II, 66–68; Hartswick 2018, 342–343.

² Allison 2004, 84–85. In her sample there were 18 houses with open garden areas.

³ Farrar 2000, 103–104, 195; von Stackelberg 2009, 24–27; *Pompeii AD 79*, 51; Hartswick 2018, 345–347.

⁴ Among Casa dello Scultore's marble sculpture there were also herms, one at least of red marble. Shops for bronze statues, and at least one head of Dionysus used to decorate a wooden piece of furniture that was produced in Rome, have also been discovered. Mustilli 1950, 215–216, 218–222; Döhl 1976 I, 49.

⁵ The area of the garden was measured during the EPUH project. For this information I am indebted to Maija Holappa from the survey team.

⁶ The great number of Bacchic representations were quickly identified, e.g. Falkener 1852, 83. – Dionysiac and Dionysus would perhaps be more common terms. The ancient Pompeians most commonly called this god Liber or sometimes Bacchus, although the iconography was clearly Hellenistic, which would favour Dionysiac.

⁷ More statues were reported in e.g. II 2,2 Casa di D. Octavius Quartio, with Egyptian and Bacchic features, and some animal statues. The garden is very large, covering over half of the insula.

niche on the eastern side of the garden. The British architect and scholar Edward Falkener, working in Pompeii during the excavations of 1847, wrote: “This apartment has a *pluteus*, or *podium* wall, at the back, the opening above which, looking towards the peristylum, affords a view of one of the most singular scenes yet discovered in Pompeii. A number of statues, some of which are the most grotesque of description, are ranged around a circular basin, and their number and variety produce the effect of a dramatic representation.” He even compared the view to a marionette theatre.⁸

Due to the house being constructed on a slightly sloping terrain, the peristyle garden is on a higher level than the tablinum. This is not a conventional garden surrounded by columns, but is rather surrounded by walls of differing heights, and two pilasters. The only entrances to the garden were from the southeast corner, which also featured a raised perspective that provided the best view of the statues.⁹ The sculpture collection is now scattered throughout several collections. Most of the pieces are still today in Pompeii (*Parco Archeologico di Pompei*), but some are in the Archaeological Museum of Naples (*Museo Archeologico Nazionale di Napoli*), and at least two have been stolen.

In this article, a review of the material is made and presented as a catalogue. By collecting all available information in one place, including previous articles, other documented material, and also previously unpublished material, the aim is to create a comprehensive list of the marble sculpture and provide an accurate report of the current status quo. I have been able to personally examine all of the statues in the Pompeii and Naples collections except for the newly identified mask No. 20, and of course the stolen items.¹⁰

The Original Amount of Sculpture

The original amount of the various pieces of recovered garden sculpture is somewhat difficult to verify, as the excavators were not exact in their reports. In *Pompeianarum antiquitatum historia* (PAH) only 21 pieces are mentioned. Some are described with detailed information and measurements, and some not. The following statues were reported with measurements: Pan and satyr (No. 6), Dolphin, Cupid, and an octopus (No. 9), one herm (No. 2), and a hare eating grapes (No. 11), which were all found on the 24th of April in 1847. The diameter of an oscillum (No. 21) discovered on the 26th was recorded, but no measurements were taken of a broken ibis (No. 18) uncovered on the same day. On the 28th the measurements of a satyr (No. 7) were recorded, as well those of a duck (No. 16) and a deer (No. 14) on the 29th, but not those of a herm (No. 3).

A satyr with a goat and a kid (No. 8), found on the 3rd of May, had its measurements recorded, but a cow (No. 15) and another ibis (No. 17) discovered on the 4th of May were not measured. On the 12th a Silenus (No. 1) was measured, but two herms (No. 4 & 5)

⁸ Falkener 1852, 55–56.

⁹ The main rooms of the house were the atrium, tablinum, and triclinium no. 16. See App. 3 for the plan of the house.

¹⁰ The first draft for this article was published in *Domus Pompeiana*, 127–137.

were not. One oscillum was found on the 19th, but the only information given was its form (pelta lunata), and consequently it is impossible to say which one of the many recovered oscilla it actually is. On the 22nd of May another group with a dolphin, Cupid, and an octopus (No. 10) was found, with the only information recorded being that it was of the same type as the previous one. The last marbles reported were a mask (No. 20) and a pinax (No. 26), both discovered on the 25th of May, and a fragmented oscillum (pelta) on the 8th of June (No. 25).¹¹ PAH also mentioned marbles from the other parts of the house, of which a bust of Bacchus (No. 19) was recorded with measurements on the 24th of March. Two other fragmentary statues were also discovered. The first (No. 27) was perhaps a Silenus, as its left hand may have held a wineskin. The other (No. 28) was a tree trunk meant to serve as a structural support, which is a common feature of marble statues, particularly marble copies of bronze originals.¹² Out of the 18 statues recovered from the garden, only 16 were reported: both of the remaining hares were not mentioned in the PAH report. Three oscilla, a pinax, and a mask were also mentioned. Bernardo Quaranta published the finds according to the date of the discovery in the *Annali civili del regno delle Due Sicilie* in 1847, but he also missed some, e.g. the finds of the 24th of April altogether. The information on the oscilla has also very few details.¹³

Falkener mentioned all 18 of the statues. He was not completely accurate in his identification of the animals, understandably so due to the fragmentary condition of some of the statues. He wrote that there were “no fewer than four suspended *disci* for intercolumniations” and a marble mask that could have been used either in the garden or upstairs.¹⁴ Guglielmo Bechi¹⁵ also listed 18 statues, but did not mention the oscilla at all. He also published a good picture of the garden showing all the statues.¹⁶ Lucia Anna D’Acunto, in *Marmora Pompeiana nel Museo Archeologico Nazionale di Napoli. Gli arredi scultorei delle case pompeiane (Marmora pompeiana)* reports four oscilla, the same amount as in PAH and Falkener. These are the round oscillum (MANN 6648, No. 21), two pelta-shaped examples (MANN 6663, No. 22 and MANN 6669, No. 23), and the pinax (San Giorgio inv. 1630, No. 26).¹⁷ However, Eugene J. Dwyer listed two more, a pelta (No. 24) and another pelta (San Giorgio inv. 1632 No. 25).¹⁸ The discrepancy is not easy to resolve. The Archaeological Museum in Naples kept records of incoming material, and the *Registro delle immissioni* listed those which should have been sent to Naples on the 22nd of July 1847,

¹¹ PAH II, 463–465.

¹² PAH II, 460–461; Döhl 1976 I, 52. The fragmented “Silenos” was found on the 24th of March, and the tree trunk on the 10th of April 1847.

¹³ Quaranta 1847, 73–75. There is no date of the 24th of April at all. The first oscillum (No. 21) is defined very clearly but the second only “*uno scudo da intercolumnio*”, the third is “*a forma di pelta lunata*”. The pinax (No. 26) is said to be “*due frammenti di scudo di forma quadrata per intercolumnio*”. The mask (No. 20) is also precisely defined.

¹⁴ Falkener 1852, 73–78. The idea of a fountain ornament upstairs seems quite rare.

¹⁵ Bechi was the *architetto direttore dello scavo* 1851–1852.

¹⁶ Bechi 1852, frontispizio and 12–13.

¹⁷ D’Acunto 2008, 166–168.

¹⁸ Dwyer 1982, 38–40.

and which were registered in the museum: a Bacchic head (San Giorgio inv. 1626, No. 19), a fragmented statue (No. 27) which however remained in Pompeii, a shield in the form of a pelta lunata (San Giorgio inv. 1628, No. 22), a Cupid riding a dolphin being attacked by an octopus (either No. 9 or 10) which also remained in Pompeii, a mask (no. Magazzino 456, San Giorgio inv. 1629, No. 20), and two fragments of a square shield (no. Magazzino 456, No. 26), and a shield in the form of a pelta lunata (San Giorgio inv. 1632, No. 25) which can no longer be located.¹⁹ It thus seems that pieces were lost at both ends of the transport system.

The small statues seem to have been easily forgotten by previous scholars, perhaps for the simple reason that some statues were removed to other places, or that the garden was a little unkept and the smaller pieces were hidden from view. The omission can be seen in Theodor Panofka,²⁰ Désiré Raoul-Rochette,²¹ and even Giuseppe Fiorelli,²² who all forgot to mention the other dolphin carrying a cupid in their descriptions. Fiorelli listed the stolen hare (No. 11) in his description of Pompeii, even if he identified it as a dog, although it must have been lost for a longer time.²³ Guide books for wider audiences copied these inaccurate lists without examining the actual statues.²⁴ In addition, the *Inventario del materiale archeologico mobile esistente negli Scavi di Pompei (Inventario)*, made in 1925–1927, lists only sixteen statues in the garden; for unknown reasons, the deer (No. 14) was not included in that catalogue.²⁵ The American garden archaeologist Wilhelmina Jashemski, for her part, had a list of all 18 statues in her first description in 1979, but omitted the missing hare in her second description in 1993. The number of oscilla were reported at first as only four (two peltae, one circular, and one rectangular oscillum), but later she accepted at least five as a result of the stylistic attribution made by Dwyer.²⁶

The exact amount of sculpture that can be attributed to the garden of Marcus Lucretius is thus problematic, and not only due to the discrepancies in the various excavation reports and catalogues. Three complete statues were stolen at different dates: a hare (No. 11)

¹⁹ *Registro* dates this to the 22nd of February in 1847, but *Notamento* has the right month. Dwyer 1982 uses the *Notamento*, which is clear considering the attributed date of the excavation.

²⁰ Panofka 1847, 133. – Panofka was a German scholar, one of the founders of the Roman Hyperboreans, out of which the *Instituto di corrispondenza archeologica* was formed.

²¹ Raoul-Rochette 1852, 67, 236, 301. – This French scholar's information about the transportation of the most valuable wall paintings is extremely important, but concerning the sculpture he relied too much on Panofka's article.

²² Fiorelli started more scientific excavations in Pompeii. He was the *ispettore* 1847–1849 and 1860–1863, and the *soprintendente* 1863–1875. After that he was the director general of Italian Antiquities and Fine Arts. The list of Pompeian officials by Fiorelli and Zangemeister is published as an appendix by Laidlaw 2007, 633–634.

²³ Fiorelli 1875, 393–395.

²⁴ An example of this is also W. Butler's *Pompeji Descriptive and Picturesque* and even August Mau's *Pompeji in Leben und Kunst*. Mau 1908, 372–373: only five statues: a Silenus, two ducks, a satyr, and an Amor riding a dolphin attacked by a polyp. These were happily in the middle of flowers – *die sich zwischen den jetzt wieder angepflanzten Blumen freundlich genug ausnehmen*; Butler 1886, 98: a list of 12 statues round the basin but with a dog and only one Cupid.

²⁵ *Inventario* 207–210.

²⁶ Jashemski 1979, 41–43; Jashemski 1993, 231–233.

soon after the excavation, and two others later. The Silenus (No.1) was recovered later.²⁷ In this catalogue, 28 marble objects are analysed. They all most probably originate from the excavation of 1847. The free-standing sculpture discovered in the garden can be divided into two groups: mythological subjects and animal figures. Out of the original eighteen, two statues are now completely lost and few are intact. Six reliefs (oscillum, pinax) are also analysed. A marble mask (No. 20) was considered lost, but has now been rediscovered in the museum. A marble hermal bust (No. 19) is also included in the catalogue, even though it was discovered outside the garden, due to its material. Two marble fragments mentioned above as discovered in the atrium are likewise included in the catalogue, even if they remain lost for the time being.

The Composition

The entrance to the House of Marcus Lucretius was discovered in 1843, but the excavations at the street level only started in late 1846, and the house was mostly excavated in

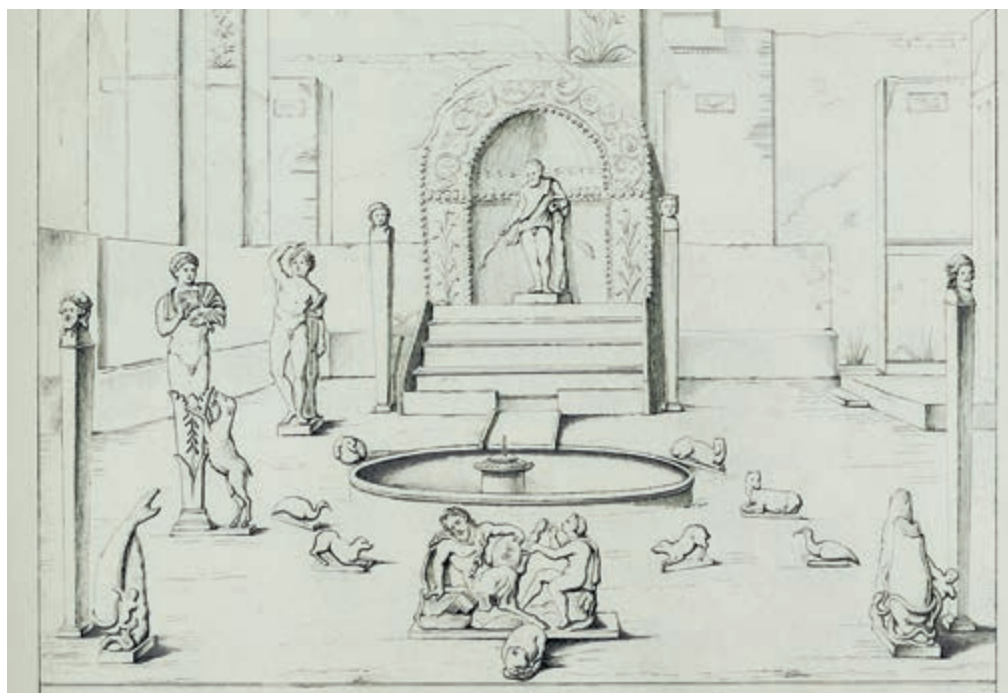

Fig. 1. Giuseppe Abbatè's drawing was engraved by Luigi Buonocore and published as a frontispiece in Real Museo Borbonico 14 (1852). It depicts all 18 statues in the garden.

²⁷ Dwyer 1982, 47, xxi. – Lost parts of the other statues may also have been stolen, e.g. the head of a double herm (No. 5).

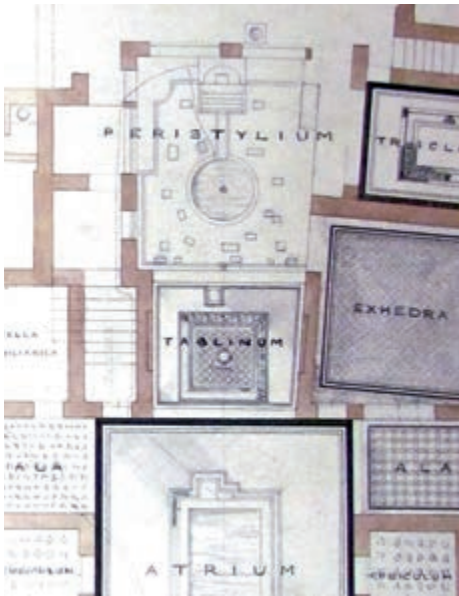

Fig. 2 (above). Detail of Edward Falkener's own drawing. The exact positions of the statues are indicated with rectangles, but the position of the duck (No. 16) is missing. The garden (18) is depicted in the middle as a peristylum and the triclinium (16) is labelled as an exhedra.

Fig. 3 (below). The map published by Overbeck 1856, 216 and Overbeck – Mau 1884, 314. The locations of some statues are indicated with letters.



1847, excepting the extension which was carried out in early 1848.²⁸ The documentation of the sculptural decoration is known from several drawings, watercolours, and photographs.

Giuseppe Abbate was an authorized illustrator (*disegnatore*) for the Pompeian excavations for thirty years, 1835–1866. He worked on the House of Marcus Lucretius in 1847–1848, during the exact years of the excavation. His drawing of the garden was published as an engraving in 1852.²⁹ (Fig. 1.) Some of his other drawings of the house were published in *Le case ed i monumenti di Pompei disegnati e descritti*.³⁰

Falkener visited Pompeii in 1846–1847 for half a year, the time during which most of the excavations were carried out in Marcus Lucretius' house. He revisited the site in 1849. He published his report, which included several drawings, in *The Museum of Classical Antiquities: A Series of Papers on Ancient*

Art, originally no. 5, in March 1852; these papers were published as a book in 1855, reprinted in 1860. He had no permission to take measurements or make proper drawings, so he only made hasty sketches at the site.³¹

²⁸ Raoul-Rochette 1852, 66; Viitanen 2008, 166–168.

²⁹ Abbate's drawings of the House of Marcus Lucretius with dates are from 1847 and 1848, one even from 1860. *PPM Disegnatori* 1995, 238, 340–366; MB 14, frontispiece.

³⁰ Niccolini 1854, Casa di M. Lucrezio, e.g. tav. 4 shows the garden view.

³¹ Falkener 1852, 37–38, 65, 67, 88; Falkener's archives are at Porthill House, Devon. He made also several archaeological



Fig. 4. The map published by Breton 1855, 298 and 1870, 388. The locations of all the statues are indicated by numbers, explained in pp. 305–306 and 395–396. Number 42 is not explained but it refers to the roundish stone (Cat. 342). This polished black stone was discovered in room 23 (in this map 30) but moved quickly to the garden by the authorities in Pompeii. See Figs. 24 and 57.

Several old photos are published in *Fotografi a Pompei nell'800*, but these are all later, e.g. a picture by James Graham ca. 1862. The viewpoint of the photos was from west to east, either from the atrium 2 or from the tablinum 15 towards the garden.³⁵

Due to its fame in the mid and the late 19th century, the house was depicted widely in various media. In the early 19th century it became less prominent as new excavations came to the fore, e.g. of the house of the Vettii and the Villa dei Misteri.³⁶ However, it retained its popularity due to the abundance of its statues.

Of the old photographs, the most important ones were taken by Robert Rive, who moved from Prussia to Naples in 1850. He received official permission to photograph in Pompeii in 1859 for the Prussian king, who had visited the site one year earlier. He made two campaigns, in 1868 and in 1895, and published an album of Pompeian views.³² The picture (Fig. 5) now in the Getty Research Institute is clearly from the earlier study, most probably from 1859, and shows the hare eating grapes (No. 11).³³ The photo in the later published album (no. 119) no longer shows that piece.³⁴ Another German working in this field was Giorgio Sommer, who started to take photos in Naples in 1857.

watercolours from the Mediterranean. His watercolour reconstruction (depicting the tablinum and the garden, probably from the year 1847, is one of the rare pictures showing the free-standing statues which were later stolen, in the front of the garden. I am grateful to Mr. and Mrs. M. Portman for informing me of them and letting me study this ancestral collection.

³² De Carolis 2013, 9, 14; Dall'Olio 2016, 12.

³³ Joseph Armstrong Baird collection of nineteenth century architectural photographs 88.R.8, box 37, Getty Research Institute.

³⁴ De Carolis 2013, 33–35, 91.

³⁵ Dall'Olio 2016, 14; – *Fotografi*, 54, 58, 95, 96.

³⁶ Dwyer 1982, 15; Mastroberro 1992, 39. The garden of the Casa dei Vettii, which was excavated 1894–1895, turned out to be important for research, and its discovery was followed by that of several other gardens.

A Roman atrium was visually transparent. From the entrance there was a vista through the heart of the house, towards the garden and beyond. The aim was to make an impression on everyone, both visitors and the broader public, as it was visible to all passing the house. The display of sculpture was an important part of this.³⁷ The practice was so embedded in culture that there was even a law requiring home owners to keep their doors open.³⁸ In Marcus Lucretius' house the *aedicula* was the primary spot for viewers to take in the house, from all directions except from behind. The pieces of sculpture were arranged into different groups: the smallest ones were mainly positioned around the circular basin. The larger statues were situated either on the northern or eastern sides of the garden. On

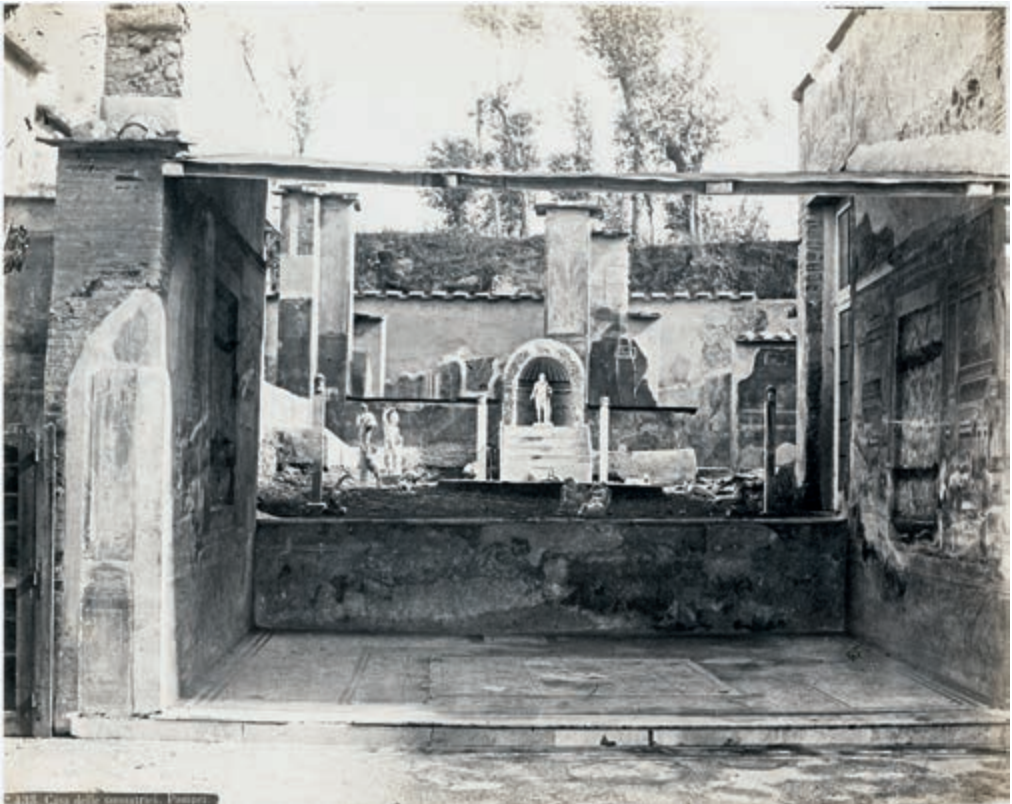

Fig. 5 Robert Rive's photo no. 433 ca. 1859 with the first modern name of the house, *Casa delle suolatrici*, after the painting at the entrance of the house. The hare No. 11 is still there, and the protective roof built over the *tablinum* is in place. The roof is also visible in some pictures published in guidebooks, such as Dyer 1867, 84–85. (Getty Research Institute.)

³⁷ Wallace-Hadrill 1988, 82–83; Hartswick 2018, 365.

³⁸ The idea to keep doors open comes from a sumptuary law: *et imperari coepit ut patentibus ianuis pransitaretur et coenitaretur, sic oculis civium testibus factis luxuria modus fieret*. Macr. Sat. 3,17,1.

the southern side of the garden, the view through the window from the triclinium (16) was kept free. Though it was clearly important for the banquet guests, reclining on their dining couches, to see the garden, the window may have been open mainly after sunset, because of the costly cinnabar used in the wall paintings – cinnabar changes from red to black quickly when exposed to direct sunlight.

Dwyer's ideal radial lines of sight do not take into account other rooms besides the tablinum 15 (also atrium 2) and triclinium 16.³⁹ (Fig. 6.) There was another triclinium 25, as well as the small corridor rooms 19 and 20, the latter of which was the "study" of M. Lucretius,⁴⁰ with openings onto the garden. Döhl took both the triclinia into consideration emphasizing that the main view was from the atrium/tablinum.⁴¹ The only rooms from which one can properly enter the garden are the triclinium 25, from which there are some steps down to the garden, and from the south end of the peristylum corridor 41. The tablinum 15 and the other triclinium 16 are on a lower level. There were some shutters or even windows in the openings, although no discernible traces exist facing the tablinum. The other rooms surrounding the garden are on the upper level, a little higher than the garden, and are separated by a wall, which mostly separates corridor 41 as well. The big openings between the pilasters remained mostly open. Linda Farrar believed that in most cases garden sculptures were placed facing the garden, and the House of Marcus Lucretius was exceptional, as the view towards the main rooms was so important.⁴²

The idea of having animal sculptures in gardens was clearly of Hellenistic origin. Alexandrian processions may have included hundreds of live animals, together with Dionysiac figures. The game parks or *paradeisoi* of the time were another influential element.⁴³ Dwyer wrote that animal sculpture was particularly suitable to groupings, although these groups may not have had any kind of interaction with each other.⁴⁴

The statues were placed around the basin and had no common scale. The exact locations may have changed after the excavation.⁴⁵ After the excavation the statues were placed on new bases, and were most probably set up near their original locations. In the middle of the basin there was a column with a water spout. The small garden of Marcus Lucretius was clearly a place for display, meant for those viewing the statues from the neighbouring rooms.⁴⁶ The main view point, the fountain *aedicula*, is of a rare type, as it is without a

³⁹ Dwyer 1982, 40–41. Although the text comments on the view from room 25 as well; von Stackelberg 2009, 26. – To have several dining rooms around a peristyle garden was customary in opulent Pompeian houses.

⁴⁰ See Castrén p. 17 and Varone p. 29.

⁴¹ Döhl 1976 II, 145.

⁴² Farrar 2000, 99. Her main example of sculpture facing the garden itself is the Casa degli Amorini Dorati (VI 16,7).

⁴³ Appleton 1987, 143–148.

⁴⁴ Dwyer 1982, 126.

⁴⁵ Döhl 1976 II, 144: The most critical locations would be those of the Cupid-dolphin groups and all the small animals around the basin; Raoul-Rochette 1852, 302: the statues are in the same places where they were discovered. – This means that they tried at least to keep things in the places in which they were found.

⁴⁶ Döhl 1976 II, 141–142: *war aber sicher nicht als betretbarer Garten, sonder als reiner 'Schaugarten' konzipiert.* – But from rooms 25 and 41 one might easily have entered it. Döhl's idea for the greatly differing parts of the house is too limited.

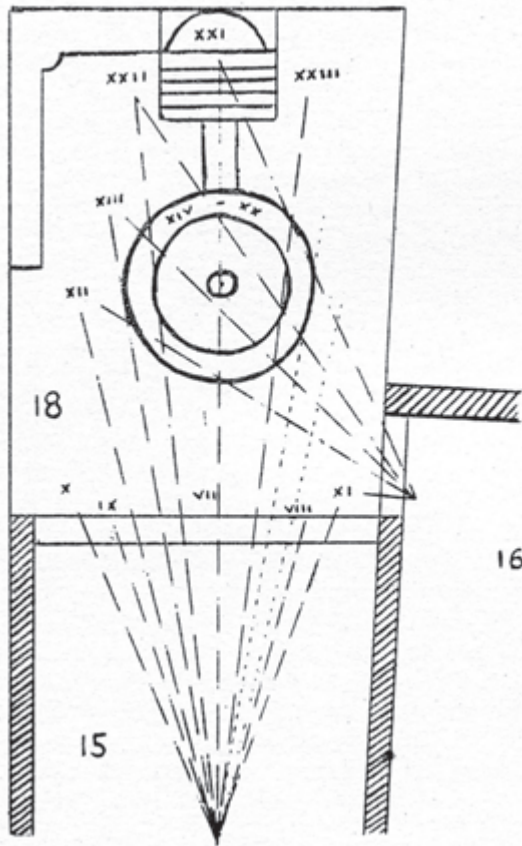

Fig. 6. Dwyer 1982, 41, fig. 1. Sculptural arrangement of garden with principal vantage points. This shows the views from the atrium/tablinum and the triclinium 16 only.

triangular pediment (the most common type in Pompeian gardens).⁴⁷

The openings in the peristyle for the oscilla were as follows: in front of room 20 there was an open space towards the northeast corner pilaster, possibly providing space for two oscilla; on both sides of the *aedicula* there were openings to peristylum corridor 41, yielding enough space for one oscillum in each. The opening to triclinium 25 was also wide, but accounting for the doors allows for at least one oscillum. There must have been shutters to be used during winter for the openings facing towards triclinium 16 and tablinum 15, which may have also had an oscillum. Thus, seven oscilla could have been inserted around the garden. More could have been affixed upstairs as well.⁴⁸ According to Jean-Marie Pailler, 47% of the oscilla in Pompeii were round disks (*tondo*), 30.5% *peltae*, and 22.5% *pinakes*.⁴⁹ In wall paintings, the *pinakes* are depicted either standing on slender pillars or hanging from the entablature. The hanging type is known e.g. from a painting of uncertain provenance.

All the types could have been used or reused in different ways, not only suspended but also affixed to a post or even placed on a wall. Only their size would have limited their use.⁵⁰ The dating of marble oscilla is to the third or fourth quarters of the first century AD, since they were commonly found in the houses of the leading families of the latest phase in Pompeii. Dwyer's main point supporting this hypothesis was the House of Marcus Lucretius, together with the house of Fortuna (IX 7, 20).⁵¹ As a *decurio* and *flamen* of Mars, Marcus

⁴⁷ Neuerburg 1965, 61–62.

⁴⁸ Falkener 1852, 73. There were upper floor rooms above rooms 19 and 20 on the northern side.

⁴⁹ Pailler 1982, 784.

⁵⁰ Jashemski 1993, 392, fig. 475; Farrar 2000, 127; De Carolis 2007, 147.

⁵¹ Dwyer 1981, 256–257; Pailler 1982, 785, 790–791. The dating was considered Augustan by Lippold 1921, 35, but

Lucretius certainly belonged to the higher circles of society, even though his house was not very large.⁵²

Previous Evaluations of the Collection

The House of Marcus Lucretius is remarkable for many reasons, most importantly for its garden, so small but so full of decorations. In the 19th century many scholars were critical of the selection of sculpture; the paintings of the house itself were considered to be of high quality, but the garden was considered to be in poor taste.⁵³ Marc Monnier's influential guidebook commented:

“The House of Marcus Lucretius. – Very curious. A peristyle forming a sort of platform, occupied with baubles, which they have had the good taste to leave there; a miniature fountain, little tiers of seats, a small conduit, a small fish-tank, grotesque little figures in bronze, statuettes and images of all sorts, – Bacchus and Bacchantes, Fauns and Satyrs, one of which, with its arm raised above its head, is charming. Another in the form of a Hermes holds a kid in its arms; the she-goat trying to get a glimpse of her little one, is raising her fore-feet as though to clamber up on the spoiler. These odds and ends make up a pretty collection of toys, a shelf, as it were, on an ancient what-not of knick-knacks.”⁵⁴

Döhl wrote that Marcus Lucretius wanted to collect fashionable objects in his small garden, but that there were too many of them arranged in faulty combinations. Even the *aedicula* was situated badly, the animals around the basin did not belong together, the architecture was asymmetric, and the pilasters were wrongly placed. He considered that Marcus Lucretius was a philistine who wanted to impress his neighbours.⁵⁵ Dwyer thought, on the other hand, that the atrium was not “very solemn due to the effect of the garden statuettes.”⁵⁶ A better opinion was held by Graham Appleton, who wrote that “an accomplished sculptural display was found in the garden of the Casa di Marcus Lucretius.”⁵⁷ Kim J. Hartswick gave

Dwyer puts it later.

⁵² Dwyer 1982, 21–23; Castrén 2008, 27–29.

⁵³ Breton 1855, 298 & Breton 1870, 387: *Elle est plus remarquable par l'abondance des ornements, par quelques détails particuliers et la bizarre disposition de son xyste que par le goût qui avait présidé à sa décoration. Les peintures qu'on y a trouvées, les sculptures qui y sont restées en place sont d'un mérite très inégal, et les pavés sont généralement peu soignés.*; Overbeck 1856, 219: *Der Peristylhof ist nicht, wie gewöhnlich, durch ein Viridarium geschmückt, sondern in einer ganz eigenthümlichen und im Ganzen herzlich geschmacklosen Weise eingerichtet und verziert.*

⁵⁴ Monnier 1871, 169. The original French version was published 1864 and had several editions. It was also favoured by Johannes Overbeck. Moormann 2015, 57–58. – The false idea of bronze statues is noticeable.

⁵⁵ Döhl 1976 II, 144–146: *Marcus Lucretius ist offenbar trotz seines Reichthums und trotz der reichen Ausstattung seines Hauses nicht mehr und nicht weniger als ein Banause.*

⁵⁶ Dwyer 1982, 125, note 4.

⁵⁷ Appleton 1987, 151.

another positive thought of the statues making a modest garden more grandiose, writing also that “these sculptures were not merely bric-à-brac but had been set up in order to enhance the view of the *nymphaeum* at the back of the garden.”⁵⁸

The idea of a broader combination of sculptural motifs was obviously emphasized in the garden collection. Egyptian and Bacchic themes were customarily combined in Pompeian gardens, as was also done by Marcus Lucretius. Bacchic symbols were also combined with natural elements, and even with elements associated with death.⁵⁹ Pompeian gardens, and the garden paintings as well, were full of fantasy. Lately, Shelley Hales argued that the wilderness depicted in them was seen as tamed by their respective owners.⁶⁰ There is some information that the garden owners primarily wanted to reflect their self-image through sculpture. An intellectual such as Cicero wanted to surround himself with *musae*, not with *bacchantes*,⁶¹ and Roman gardens do display their owner’s taste and aspirations.⁶²

The interpretation of the role of religion in gardens, and for their statues, has been debated over decades. Some scholars have seen more religious meanings, or even cult contexts, than others. As a continuation of the Hellenistic tradition, the gardens may have been some kind of sanctuaries of Bacchus with mystic or theatrical features.⁶³ Even the combination of wild and tame animals was a feature of the mythological *aurea aetas*.⁶⁴ Since the 1950’s this religious meaning has been contested by several scholars. The Bacchic religion was considered “little more than a pretentious hobby for the well-to-do.”⁶⁵ Thus Döhl emphasized that the Pompeian herms, masks, and double sided reliefs were mostly decorative. Further, their motifs may have been Bacchic, but the religious meaning was less important due to the large amount of them.⁶⁶ Jashemski also emphasized the lesser role of Dionysus/Bacchus compared to that of Venus in Pompeian gardens.⁶⁷ Dwyer is against attributing cultic activities to gardens in general, stating that while there may have been

⁵⁸ Hartswick 2018, 363–365. – He locates the garden falsely to the House of Marcus Lucretius Fronto (V 4,a) though.

⁵⁹ Mastroberto 1992, 41–42.

⁶⁰ Hales 2003, 155–162: “the paterfamilias who governed the bizarre fantasy world that was his home.”

⁶¹ Neudecker 1988, 29; Farrar 2000, 103; von Stackelberg 2009, 26; Cic. *fam.* 7.23,2.

⁶² Farrar 2000, 188.

⁶³ Grimal 1943, 340–346. His main example was the Casa degli Amorini Dorati (VI 16, 7), with e.g. pinakes depicting sacrifice that he linked to Liberalia; according to Dwyer, who studied five Pompeian houses with free-standing sculpture depicting the companions of Bacchus, the Sileni and satyrs were represented as protagonists. Dwyer 1982, 126: “A large number of auxiliary types, in contrast to the types of the major divinities, were designed specifically as fountains.”

⁶⁴ Kapossy 1969, 78 refers to the garden of Marcus Lucretius. This is accepted by Appleton 1987, 167 who considered that the house was inspired by larger villas.

⁶⁵ Hutchinson 1991, 229–230; Hundsalz 1987, 2, 108–109: She considered that the decorative element ran over the cultic one. See also Heinemann 2011, 392–398, 401–403, 410–412.

⁶⁶ Döhl 1976 II, 22–23. This would be supported by the use of herms and statues as table supports. His example of decorative meaning is a table support depicting Silenus and the infant Dionysus from the Casa del principe di Napoli (VI 15,8), now P 53562. He also refers to Tran Tam Tinh 1975, 282–283 who discusses the religious role of Attis in Pompeii and also hints at a Dionysus used as a table support.

⁶⁷ Jashemski 1979, 123–124. She wrote that there is little evidence to support the theory that every garden would be a temple of Dionysus, and the only clear case is the garden of his temple near Sant’Abbondio. – The most important deity in Pompeii was Venus, who was also the goddess of gardens. Venus was linked with Mars as an agricultural god, and also with Eros. Von Stackelberg 2009, 27. About the role of deities in gardens see also Dwyer 1982, 124–126.

statues of deities in the gardens, worshipping them would not have been comparable to the cults of the *lararium* inside the houses.⁶⁸ He also wrote that the suspended shields would only have been “Dionysiac toys.”⁶⁹

Farrar’s sample of ancient Roman sites with gardens shows that statues of Venus existed in the Vesuvian area, but the Bacchic element was more popular in sculpture, although Bacchus himself was rarely depicted as a statue.⁷⁰ More recent studies have shown that archaeological evidence could shed more light on the role of the “*Dionysiaca*”.⁷¹ Oscilla have been assessed to have complex origins. They clearly had different meanings for their Roman users.⁷²

As to the role of religion in the House of Marcus Lucretius specifically, Falkener wrote about the theatrical wall paintings with actors and masks, which were an important part of the decorative scheme. Besides the large paintings depicting triumphs of Bacchus, there were also Bacchic heads in the *oecus* behind the garden (room 21). He continued: “Most of the statues in the garden also were Bacchic, there being four hermal statues of Bacchus, in addition to the figure of Marsyas. We cannot consider that all this is a matter of chance, but must rather regard them as bearing some references to the pursuits of the owner of the house. I imagine, therefore, that the proprietor was a *poet*.”⁷³

Catalogue

The catalogue is organised according to the subject of the sculpture. Firstly come mythological free-standing single figures or groups still in Pompeii: Silenus, Bacchus, satyrs, Pan (either statues or herms) and Cupids with animals. Secondly come pure animal statues. Thirdly come those moved to Naples, a heterogeneous group of sculptures and oscilla, i.e. suspended relief sculpted on both sides. The description of each item covers the pose from feet to head, and from a broad overview of the whole to details; the words right and left refer to the figure’s proper right and left. For groups, the description starts with the main figure, or the figure in front. Under decoration, any traces of painted colour and metal are noted, as well as any that are known from previous documentation.⁷⁴ Abbreviations used in the catalogue are:

⁶⁸ Dwyer 1982, 118, 126: Dwyer firstly saw Mau’s interpretation as problematic and Grimal as having made a real error, but admitted later that “In a number of cases this approaches a true religious spirit.”

⁶⁹ Dwyer 1982, 119. Pure decorative meaning despite religious Dionysiac origins was already favoured much earlier e.g. Lippold 1921, 36, 40–41.

⁷⁰ Jashemski 1979, 124–131; Farrar 2000, 126, [204–205] table 1. – Children and animals were the most popular subjects of statues, but herms and oscilla were not counted according to their motifs, making the statistics unreliable. – Unlike most major natural and agricultural deities (Mars, Venus, Apollo, and Diana) Bacchus appears with companions, in this case with members of the *thiasos* or animals. Dwyer 1982, 123.

⁷¹ Hutchinson 1991, 229–230: criticizes scholars for not admitting any religious role for the Bacchic objects.

⁷² Taylor 2005, 83–88, 102.

⁷³ Falkener 1852, 83–84.

⁷⁴ The colours were observed with bare eyes, except for the ones restored professionally in 2008.

D = diameter

DPT= depth

H = height

L = length

MANN = Museo Archeologico Nazionale di Napoli, the Naples Museum inventory number of the catalogue of Fiorelli

P = Pompeii inventory number in the card catalogue at the Deposito of Casa di Bacco; “former” means previous catalogue *Inventario del materiale archeologico mobile esistente negli Scavi di Pompei*.

p = preserved

San Giorgio inv. = Ms. inventory of the Naples Museum, compiled ca. 1840–1868.

Th = thickness

W = width

The directions are given as if north were on the left looking from the tablinum 15 to the garden 18, while the real left for the garden would be northwest. The left means the northern side, and the right the southern side of the garden.

I.1.1 Silenus (Figs. 7–8, Cat. 268)

P20392 (former 2051).

Place of discovery: Garden (18), niche (*aedicula*) on the east side (12.5.1847).

Dimensions: H 68.0; W with arms 30.0; H with base 77.0.

Technique: Some parts are roughly made, e.g. the tunnel for the water pipe had not been polished. A drill was used e.g. on the ears and beard.⁷⁵

Marble: Parian, white, slightly pinkish, crystalline.

Decoration: Traces of colour when found, e.g. the wine-skin was black and beard and hair reddish. No colours are preserved.

Condition: Surface of marble is eroded. Right hand is not preserved and was missing already in 1927. During conservation in 2008 the feet were re-united with the legs.

Bibliography: PAH II, 464: *un Sileno, la sua altezza e di circa pal. 2 5/10*; Panofka 1847, 133: *Sileno*; Quaranta 1847, 74: *Sileno, alta palmi 2 3/10*; Pancaldi 1848, 30; Falkener 1852, 74: Marsyas with reference to the Phrygian character of the house; Bechi 1852, 12: *Sileno... marmo pentelico*; Nicolini 1854, 17; Minervini 1855, 56: *Sileno*; Breton 1855, 305; Fiorelli 1875, 393; Dyer 1875, 459; Neuerburg 1965, 132; Kapossy 1969, 30, 59, 77; Döhl 1976 I, 53; Jashemski 1979, 41–42; Hill 1981, 84: Hercules; Dwyer 1982, 47:xxi, pl. XIV, fig. 51; Jashemski 1993, 231, 233 fig. 268; Kuivalainen 2008, 129–130.

Description and comments: Old Silenus is depicted standing and wearing a short tunic of animal skin, probably of panther, below which his genitals are visible. The tunic goes over the left shoulder, leaving the right bare. The right arm is held downwards to the side, the missing hand was turned a little outwards. The left elbow is resting on a tree stump. Under the left arm is a wineskin, which has

⁷⁵ Appleton 1987, 228. He points out the extra work that would have been necessary to bore through the sculpture to make a water channel.

an opening to serve as a fountain, with a separate mouthpiece with a hole 0.6 cm wide. At the back of the stump there is a vertical groove (36 cm x 3–4 cm) for a water pipe. This drunken Silenus was displayed in the *aedicula*, from which water ran over the steps to a lower circular basin, and was clearly the main focus of the garden. Iconography of this type is quite common; Kapossy has listed five of them. In Pompeii the closest parallel was found in the Casa del Granduca di Toscana (VII 4,56).⁷⁶ There is a statue of another iconographic type now in Naples with no information of its specific find location;



Figs. 7–8.

but according to Dwyer it could be identified with a statue found in Pompeii,⁷⁷ most probably in the Villa di Cicerone outside the Herculaneum gate.⁷⁸

I.1.2 Bacchic double herm⁷⁹ (Fig. 9, Cat. 238)

P20627 (former 2059).

Place of discovery: Garden (18), northwest corner, left foreground (29.4.1847).

Dimensions: H protome 20.3, with pillar 119.0; DPT pillar 12.6; W pillar 9.4; H with base 129.8.

⁷⁶ Kapossy 1969, 30. Two statues are now in Naples (MANN 6341 from the Casa del Granduca and the other MANN 6349), one in the Louvre and one in the Vatican. Silenus is not the only member of the Dionysiac *thiasos* to be displayed in Pompeian *aediculae*, but is the most common one, Dwyer 1982, 124.

⁷⁷ According to Dwyer 1982, 47 note 2, its height is 61.0 using as his source *PAHI*, 9. It was found 1.3.1749 and published already in Bayardi 1755, 147–148, no. XXXXXVII.

⁷⁸ The inscription *CIL X*, 1063 was found nearby, thus the statue should be from this site.

⁷⁹ The double (bicipital) herms are defined as "janiform, where two busts facing outwards share the one shaft". Farrar 2000, 122–123.

Technique: The protome is finely crafted. There are shallow rectangular cuttings for the attachment of the bosses (rudimentary arms). Marks from both claw and flat chisels are visible. A drill was used, e.g. for a hole between the neck and the curls on the right side of the young head. There are also shallow drillings in other details. The area under the beard is only roughly finished, due to it not being visible.

Marble: Protome white. The pillar with grey veins possibly Carrara.

Decoration: Some coloured areas probably caused by iron.

Condition: Various points are damaged, e.g. there are three fractures in the pillar. The protome is joined to the shaft with plaster. The bearded head's left temple is broken.

Bibliography: PAH II, 463: *Un'erma bicipite rappresentante un Bacco indiano ed un'Arianna*; Panofka 1847, 133: *Mercurio e Vesta*; Quaranta 1847, 74: *una bicipide raffigurante Bacco, ed Arianna*; Pancaldi 1848, 31; Falkener 1852, 74: with a drawing, interpreting the herm as Indian Bacchus and Ariadne; Bechi 1852, 12: *Bacco Indiano ed Arianna*; Niccolini 1854, 17: *immagini dell'imberbe a del barbato Bacco*; Minervini 1855, 56: *Bacco barbato ed imberbe*; Breton 1855, 306; Fiorelli 1875, 393; *Inventario* 209–210, *Bacco indiano e una Baccante*; Döhl 1976 I, 52; Dwyer 1982, 43:x, pl. X, fig. 36–38, bearded and unbearded Bacchus; Jashemski 1979, 42; Mastroberto 1991, 20–21; Jashemski 1993, 232; Kuivalainen 2008, 132.

Description and comments: Side A⁸⁰ depicts a mature male head with a full beard. Long tresses of hair fall on both sides towards the chest. The beard is divided into four s-curved rows cut straight, the outer ends of the moustache are slightly curled, and the side whiskers as well. He has a small mouth with full lips, a small nose, and straight eyes with eyelids clearly marked. Side B depicts a young beardless male head. Long tresses of hair fall downwards, two on the left, three on the right side. The fringe is composed of tight parallel curls, cut straight below very smoothly. The hair is bound with a fillet that continues round both heads. He has a round face with a small mouth, a straight small nose and eyes with clearly marked lips. The skull of side A is larger than that of side B. Between the two heads there is an impression where the skulls join. On the top of the base there is a concave moulding.

As to the identification of the double herms, the type originated in Greece, depicting divinities of tempest, night, darkness, or death, hence the identification was Hermes/Mercury. They were not very common, and became more fashionable only during the Early Empire.⁸¹ Without more specific attributes the identification is not easy,



Fig. 9.

⁸⁰ In this connection the sides are called A or B in order of the direction towards the main point of view, i.e. the tablinum and atrium.

⁸¹ Lullies 1931, 65–69; Wrede 1986, 53.

as in some cases Hermes might have Bacchic attributes.⁸² Due to the wreaths, *korymboi*, and horns the Pompeian protomes seem to depict Bacchus. This double Bacchus was a very common herm type in Pompeii, but a Bacchic herm could sometimes represent Bacchus and Ariadne, or a satyr and a maenad, although such identifications may remain doubtful.⁸³ It is difficult to determine which head is in fact Bacchus and which Mercury/Hermes in these types of sculpture. Double herms were also a sign of the passage of time, signifying that human life means a transition from youth to old age. Together with other garden decorations, they also depicted the idea of renewing nature.⁸⁴ In this way, Dionysus in two different forms was connected with the idea of continuity. The bearded Dionysus was an archaic representation of the god, the first incarnation that reappeared as a youth in the classical period.⁸⁵ In ancient literature, the fully bearded figure could be regarded as the oldest Dionysus, who was associated with India. Thus the bearded Bacchus was called the Indian Bacchus in early Pompeian reports. This association came from the mythographers of the time, who had written that Indian men carefully grew their long beards until their death.⁸⁶

I.1.3 Bacchic double herm (Figs. 10–11, Cat. 269)

P20398 head/20404 base (former 2062).

Place of discovery: Garden (18), southwest corner, right foreground, in front of the window of the room 16 (24.4.1847).

Dimensions: H protome 21.0,⁸⁷ H 120.0; DPT pillar 12.5; W pillar 8.6; H with base 131.5.

Technique: The protome is very finely carved, in some places chiselling marks are not even visible.

Marble: White.

Decoration: No traces of colour.

Condition: Two larger fractures in the pillar; shaft put together with plaster. Part of the nose and fringe of the young head are missing. There are small holes in the fringe, and one in the left eyelid.

Bibliography: PAH II, 463: *un Bacco indiano e di un' Arianna: la sua altezza esclusane quella del pilastro, sul quale è poggiata, è di quattro quinti di pal.*; Panofka 1847, 133: *Mercurio e Vesta*; Pancaldi 1848, 31; Falkener 1852, 74–75: *Indian Bacchus and Ariadne*; Bechi 1852, 12: *Bacco Indiano ed Arianna*; ; Niccolini 1854, 17: *immagini dell' imberbe e del barbato Bacco*; Breton 1855, 306; Fiorelli 1875, 393: *Bacco barbato, congiunto a teste di Satiretti o di Bacchanti.*; *Inventario* 209–210: *Bacco indiano e Baccante*; Döhl 1976 I, 52; Dwyer 1982, 43–44:xi, pl. XI, fig. 39–41, bearded and



Figs. 10–11.

⁸² Giunilia 1983, 46 & 72.

⁸³ Wrede 1986, 53, argued that only gods were depicted as herms before Pompeii was destroyed.

⁸⁴ Mastroberto 1992, 41.

⁸⁵ Turcan 1958, 283–285; Perrin 2006, 138, 140 and 142.

⁸⁶ Diod. Sic. 3,63 quotes the mythographers.

⁸⁷ This would be closest to the 4/5 of the *palma napoletana*, mentioned as the height of the head found in 24.4.1847. PAH II, 463.



Figs. 12–13.

of hair fall down on both sides. The fringe is composed of two layers of tightly set curls. The hair is bound with a fillet that goes round both heads. On the top, between the heads, a slightly depressed section is formed where the two skulls join, with side A being higher but of equal size. On the top of the base there is a concave moulding. This double herm was visible in profile to the dinner guests in triclinium 16. Nos. 2 and 3 are quite similar, probably by the same sculptor.⁸⁸

I.1.4 Bacchic double herm (Figs. 12–14, Cat. 252)

P20628 (former 2066).

Place of discovery: Garden (18), east side, north of stairs (12.5.1847).

Dimensions: H protome 18.5, H 111.5; W pillar 12.4; DPT pillar 11.9, H with base 127.7.

Technique: The protome is finely crafted. The hair was carved with a curved chisel. A drill was also used on the curls, and even perhaps on the beard, leaving accidental holes.

Marble: White with darker veins in the shaft and with violet veins in the protome, both possibly Carraran varieties.

Decoration: No traces of colour.

Condition: There is only one big diagonal fracture in the upper third of the pillar, following the natural vein of the marble. The parts are put together with modern plaster on side A. The nose of side B (the bearded Bacchus) was broken by workmen in a show re-excavation for an important visitor. It was complete when it was found.⁸⁹

Bibliography: PAH II, 464: *due pilastrini vi sono due erme bicipiti*; Panofka 1847, 133: *Bacco e Proserpina*; Quaranta 1847, 74: *due Erme bicipiti*; Pancaldi 1848, 31; Falkener 1852, 74–75, a bearded Bacchus and Ariadne; Bechi 1852, 12: *Bacco ed Arianna*; Niccolini 1854, 17: *Bacco barbato ed*

unbearded Bacchus; Jashemski 1979, 42; Jashemski 1993, 232, 233 fig. 268; Kuivalainen 2008, 132–133.

Description and comments: Side A depicts a mature male head with a full beard. Long tresses of hair fall on both sides towards the chest. The beard is divided into three s-curved rows under the chin and cut straight, with less detailed carving than in No. 2. The mouth is small, nose straight, and the eyes have clearly marked eyelids. Both cheek bones are clearly marked. The frontal view is unbalanced, e.g. the right cheek is higher than the left one, and the beard rises to the right. Side B depicts a young beardless male head. The neck is wider than in herm No. 2. Long tresses



Fig. 14. Niccolini 1854, pl. I, Figs. 7 and 8.

⁸⁸ Dwyer 1982, 44: though by a different hand.

⁸⁹ Falkener 1852, 75. Falkener himself witnessed this in 1847.

imberbe; Breton 1855, 305; Fiorelli 1875, 393; *Inventario* 209–210: *Bacco indiano e Jonico*; Döhl 1976 I, 53; Dwyer 1982, 47–48:xxii, pl. XIV, fig. 52–54; Jashemski 1979, 42; Mastroroberto 1991, 21; Jashemski 1993, 232; Kuivalainen 2008, 132–133.

Description and comments: Side A depicts a young beardless male head. He has a round face, small mouth and full lips, full cheeks, and a slanting right eye. Long curls continue to the chest, at some distance from the neck. He has an elaborate hairstyle with strong wavy curls above the ears, and a wide hairband on the forehead. Part of the hair is drawn in plaits above the forehead, forming a simple knot. On the top of the head there is a sharp parting of the hair. Side B depicts a mature man's head with a full beard. He has a curly moustache and an elaborate hairstyle, with a wide hairband on the forehead. The hair on top is arranged into a double knot in the middle. Otherwise similar to side A.

I.1.5. Bacchic double herm (Figs. 15–16, Cat. 270)

P20397 (former 2052).

Place of discovery: Garden (18), east side, south of stairs (12.5.1847).

Dimensions: p H 99.0; W pillar 10.8; DPT pillar 13.6, H with base 115.6.

Technique: The shaft and the protome were made either of the same piece of marble, or the joint was in the neck. Some use of drill, e.g. in the curly hair of the young Bacchus.

Marble: Carrara.

Decoration: No colours preserved.

Condition: The protomes are lost.⁹⁰ A steel rod was attached to the base during conservation efforts in 2008.

Bibliography: PAH II, 464; Panofka 1847, 133: *I due Bacchi, l'Ebone, ed il Giovane a corna taurine*; Quaranta 1847, 74: *due Erme bicipiti*; Pancaldi

1848, 31; Falkener 1852, 74, identified as male and female Faun; Bechi 1852, 12: *Fauno ed una Fauna*; Niccolini 1854, 17: *Bacco barbato ed imberbe, ... le due immagini del dio sono munite di piccolo corna alla fronte*, pl. I, fig. 7 & 8; Minervini 1855, 56; Breton 1855, 305; Fiorelli 1875, 393; *Inventario* 207–208, *Bacco e Baccante*; Döhl 1976 I, 53; Dwyer 1982, 48:xxiii did not see the heads;

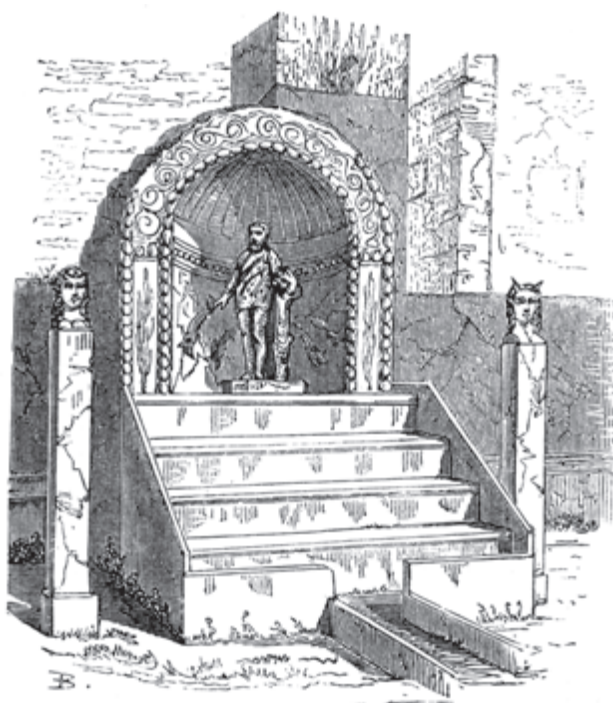

Fig. 15. Breton 1870, 394 exaggerates the size of the horns of the right side herm.

⁹⁰ The protome of the herm is still visible in the photo taken by Helen Väänänen in the early 1960's, see p. 8.



Fig. 16. Warscher 1948. (Getty Research Institute.)

Jashemski 1979, 42; Jashemski 1993, 232; Kuivalainen 2008, 132–133.

Description and comments: The identification as two types of horned Bacchus (Dionysus) was made by Niccolini; the depiction by Panofka may suggest that only the young head had horns.⁹¹ Side A depicts a young male head; this beardless severe looking head has curly hair drawn backwards, round locks, and very small horns above the temples. Side B depicts a male head with a full beard. The hair is bound with a fillet. Small horns may have been visible, but in contrast with the text

Niccolini's drawing of side B does not have visible horns. Horns are usually depicted when Bacchus is a beardless youth. The hair of both sides is joined in the back, but does not continue towards the figures' chests. Warscher's photo taken in 1948 shows a fracture in the neck, while Breton (probably erroneously) comments that the protome is cut above the shoulders as was usual.

I.1.6. Pan and satyr (Fig. 17, Cat. 234)

P former 2060. Stolen ca. 1965 and since lost.

Place of discovery: Garden (18), in the middle of the west side (24.4.1847).

Dimensions: H 32.0; W 50.0.

Technique: Very fine craftsmanship in front, back rough, drill used e.g. on Pan's beard and on the fur on the legs.

Marble: White.

Decoration: No knowledge.

Condition: Satyr's left hand from wrist and whole right forearm were lost earlier, and the rest of the group was stolen in two phases.⁹²

Bibliography: PAH II, 463: *Un gruppo rappresentante un Pane ed un Fauno, che gli cava forse una spina dal piede: la base, su cui poggiano queste due figure è di un palmo e nove decimi.*; Panofka 1847, 133; Pancaldi 1848, 31; Falkener 1852, 76, a Faun and Pan; Bechi 1852, 12: *un Pane barbuto... un giovine faunetto*; Niccolini 1854, 17: *un giovine satiretto toglie dal piede la spina ad un barbato Pane*; Minervini 1855, 56; Breton 1855, 306; Fiorelli 1875, 394: *un grazioso gruppo di Pane seduto, a cui Satirello toglie dal piede una spina*; Kapossy 1969, 60; Döhl 1976 I, 52; Hill 1981, 91–92; Dwyer 1982, 42:vii, pl. IX, fig. 33; Jashemski 1979, 43; Jashemski 1993, 232, 233 fig. 271; Kuivalainen 2008, 133.

⁹¹ Niccolini 1854, 17, note 136.

⁹² In the photo on p. 8 the satyr is already lost. Other color photos exist, but no details are discernible.

Description and comments: The composition consists of Pan on the left, sitting with his left foot lifted towards the small satyr, who is extracting a thorn from Pan's hoof. Pan sits on a stone, towards which he leans with his right hand; with his left hand he lifts his left foot; he is in obvious pain and turns his head away to the right; he is bearded, and on the top of his head there are small horns; he is wearing a cloak loosely covering his back and tied under his chin; a cord with pine cones goes across his chest; his syrinx leans on the stone. The small satyr sits on the opposite stone; he steadies himself with his extended right foot and holds Pan's hoof with both hands; with his right fingers he tries to extract the thorn, while straining his neck and gazing upwards; he wears short cloak tied under his chin but loose from his back; his hair is short and curly, probably with little horns on the top.

The composition is basically a triangle perceived from one angle; both bodies draw apart in opposite directions, with heads turned away from each other. Interestingly, the satyr does not look at the hoof at all. Unlike many satyr groups meant to be viewed all round, this one was to be seen from the front only. Iconographic parallels to this pair are known from Ostia, the Louvre, and the Vatican, but the roles are reversed, with Pan depicted in smaller scale helping the satyr in distress.⁹³ Dorothy Kent Hill considered that this was a good genre subject for gardens, because of the two-



Fig. 17. Pan and satyr. In Pompeii there are two photos of the stolen group. This is no. A177.

⁹³ Bieber 1961, 148. figs. 633–635. The group in the Louvre is more three-dimensional, inv. MR 193 (Ma 320), as is the group in Ostia. The closest parallel is clearly the one in the Vatican, which was also originally used as a fountain. An iconographic parallel claimed by Dwyer 1982, 42, known from the Casa dell'Efebo, hardly qualifies, being two lone figures.

sided effect, with the original being a late Hellenistic statue.⁹⁴ A thorn in a foot may also refer to the wounding power of love.⁹⁵

I.1.7. Satyr (Figs. 18–20, Cat. 247)

P20391 (former 2054).

Place of discovery: Garden (18), approximately in the middle of the north side, towards the east (28.4.1847).

Dimensions: H 80.0; H base 13.8; W base 25.8; DPT base 42.7.

Technique: High quality workmanship; figure with well-polished surface, back of tree trunk roughly made. Drill was used e.g. on the hair and ears.

Marble: Figure white crystalline. Base grey opaque marble with swirled veins (*bardiglio*).⁹⁶ Remains of the pillar greyish marble.

Decoration: None visible.

Condition: Left hand and fingers of the right, toes of the left foot missing. Nose is broken. Separate pillar broken above base.

Bibliography: PAH II, 463: *Una statuetta di altezza pal. 3 divisa alla base rappresentante Pane giovine, che ha una mano nella testa, e con l'altra sostiene il pedo, mancano le dita della mano destra e del piede sinistro*; Panofka 1847, 133: *un Fauno col pedum*; Quaranta 1847, 74: *una statuette alta palmi 3 raffigurante Pane giovine, che ha una mano alla testa, e coll' altra sostiene il pedo*; Pancaldi 1848, 31; Falkener 1852, 76–77: ...is possible that the Faun held a goat over his shoulders; Bechi 1852, 12–13; Niccolini 1854, 17: *un Satiro con nebride, che colla destra si fa solecchio per riparare la vista da' troppo acuti raggi dell' astro del giorno*; Minervini 1855, 56; Breton 1855, 306: *un charmant Faune [no.] 37 portant la main à sa tête*; Overbeck 1856, 374–375; Fiorelli 1875, 394; Overbeck – Mau 1884, 551, fig. 288a; Reinach 1906–1930, vol. 2 (1908), 138, no. 2; Döhl 1976 I, 52; Dwyer 1982, 44–45:xiii, PL. XII, fig. 43 a) & b); Jucker 1956, 71–72; Jashemski 1979, 43; Moss 1988, 429–430 (no. A49); Jashemski 1993, 232, 233 fig. 269; Kuivalainen 2008, 132–134.

Description and comments: The naked young man steps forward vigorously with left foot in front;⁹⁷ his right arm is raised, and he is shading his eyes with his hand (der Gestus des *apokopein*); he leans on the tree trunk with his left arm, which is covered with a panther's hide; his muscles are clearly depicted, head is turned slightly to the right, and he is gazing upwards; his face is round, with a small

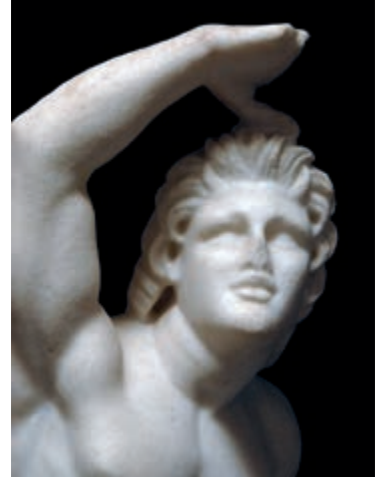

Fig. 18.

⁹⁴ Hill 1981, 91. The original may have been made in the first century BC.

⁹⁵ See Fowler 1989, 152–154. She uses the groups in the Louvre and in the Vatican as examples where “the agonized faces of the satyrs suggest that the little thorn is Eros himself”. Pan was also depicted with goats in gardens, see e.g. *Life and Death*, 168–169.

⁹⁶ Moss 1988, 429. Romans used *bardiglio* from Carrara by that time. The marble of the base could also be some darker variant.

⁹⁷ He is depicted with a ligature of the penis, perhaps in the style known in the Greek world as *kynodesme*. The model for these kind of satyrs comes from depictions of Greek athletes. See e.g. Lissarrague 1990, 59–61. The same feature is also seen in some telamons from the Forum Baths in Pompeii. I owe this information to Ville Hakanen, whose article ‘Normative Masculinity and the Decoration of the Tepidarium of the Forum Baths in Pompeii’, forthcoming, *AJA* 124.1 (2020).

mouth with full lips and deep eyes; there are small horns on his forehead, and his hair is brushed up in tufts and covers the neck. He stands on a slightly triangular plinth with rounded corners, made of the same piece of marble as the statue and the tree trunk he is leaning on. He is attached to the trunk by his left hip. The statue stands on a separate rectangular base. Behind the young man's right foot and the tree trunk there are the remains of a rectangular pillar with a moulded base.

This Aposkopos-statue seems to have been reused, first free-standing either alone or as part of a group. A parallel for a potential motif is depicted on a sarcophagus in Copenhagen, with a satyr shading his eyes in a large Dionysiac group.⁹⁸ Consequently, the statue was used as a table support, and after that appeared again as a free-standing statue in the garden.⁹⁹ Pompeian monopodia have the same features, a simple base of darker marble with a support behind the sculpted figure.¹⁰⁰ A table support with a wingless Eros was found in Thessaloniki, which has a support proper (pillar) joined with the figure; it was produced in an Attic workshop.¹⁰¹



Fig. 19.



Fig. 20. Falkener 1852, 76.

I.1.8 Satyr with goat and kid (Figs. 21–23, Cat. 254) P20393 (former 2056).

Place of discovery: Garden (18), in the middle of the north side, towards the west (3.5.1847).

Dimensions: H 82.5; W plinth 29.0, DPT plinth 14.0; H base 2.3, W base 42.9, DPT base 32.0, H goat 47.0.

Technique: The group is made of one piece of marble with attached details. A drill was used on many parts, e.g. the leaves of the pillar, the goat's and kid's fur, the nostrils and mouth.

⁹⁸ A muscular satyr is stepping aside next to a Bacchant opening a *cista mystica* with a rising serpent, Turcan 2003, 124, 139, fig. 73.

⁹⁹ Moss argued that the satyr was originally intended to be a table support, rather than being reused as such, as Dwyer thought, Moss 1988, 430; Dwyer 1982, 45, wrote about [P.H.] von Blanckenhagen's remark (without source) that the upward gaze and gesture could indicate that the satyr may have been part of a group.

¹⁰⁰ P 1109 with a silen. Mastroberro 2011, 191.

¹⁰¹ Stefanidou-Tiveriou 1997, 132–133, no. 102, figs 288–290.

Marble: White with grey veins, probably Carrara.

Decoration: Red spots in places, origin not known.

Condition: Part of the satyr's right arm was missing already when found. The head, and the head of the kid, were later stolen.

Bibliography: PAH II, 464: *Una statuetta mancante d'una metà del braccio destro, di circa pal. 3 1/3 di altezza compresa la sua base, rappresentante un Termine che tiene nel braccio sinistro un cestino entro del quale vedesi un capretto, e al di sotto la madre che gli porta da mangiare qualche cosa. Essa vedesi alzata tenendo le zampe poggiate sulla parte inferiore di detta statuetta;* Panofka 1847, 133: *l'erma di un Fauno coperto di pelle caprina;* Quaranta 1847, 74; Pancaldi 1848, 31; Falkener 1852, 77: a hermal statue of a shepherd with Pandean pipe; Bechi 1852, 13; Niccolini 1854, 17: *un erma di un giovine, la cui figura va a finire inferiormente in capriccioso fogliame;* Minervini 1855, 56; Breton 1855, 306; Fiorelli 1875, 394; Döhl 1976 I, 53; Dwyer 1982, 44:xii; Appleton 1987, 72–73 (no. 89); Jashemski 1979, 43; Jashemski 1993, 232; Kuivalainen 2008, 133–134.

Description and comments: The herm and the goat share a plinth. The herm is of the hip type¹⁰² with moulded base; the pillar is decorated with leaves, growing from the sepals below. The herm is of human shape from the thighs upwards, the hips being slightly angular; he wears a *nebris* which covers the left shoulder and is tied on the right; he holds a kid in the crook of his left arm; his right arm is bent; against his chest he held a syrinx, originally fastened to the breast bone with a piece of metal, now identifiable by the hole; another hole, larger in diameter (2.0) and deeper (4.3) than the hole for the syrinx, is on the left shoulder blade. The base under the dam is left coarse and terrain like; she stands on her hind legs and grabs the pillar with her forelegs on both sides of the pillar, trying to reach the kid; the goat's hair is marked with low curls on the back; the horns were made of separate pieces, now lost.



Figs. 21–22.

It is quite common for Pan to be depicted with a goat, but for satyrs it is rare. In Pompeii the closest parallels come from the Praedia di Iulia Felix, a statue of Pan holding a fawn (P8856, Fig. 23), and from the Casa dell'Efebo, a Pan with a goat's head (P 3682),¹⁰³ but hip-herms are not very common in Pompeii.¹⁰⁴ The herm may have

¹⁰² A hip-herm is a herm where the shaft is cloaked or partly anthropomorphized. R. Hamilton, s.v. herms, *The Oxford Encyclopedia of Ancient Greece and Rome* 3 (2010), 415.

¹⁰³ Jashemski 1993, 42.

¹⁰⁴ From Pompeii comes e.g. an archaising female herm (MANN 126251) which has a cloak over the rectangular shaft. It was used as a table support. A more naturally formed Hercules of *giallo antico* was discovered in Herculaneum (MANN 6383, *Pompeii AD 79*, 86 (no. 86), 88–89 (no. 89); the cloak was at first a real cloak supported by cross beams, but Romans



Fig. 23. Pan holding a fawn (P8856) from the Praedia di Iulia Felix.

been fastened to a wall, as is suggested by the hole in the back. This kind of a support was not needed, nor of any possible use, in its final location far from any constructed walls or columns. This could be taken as a sign of the herm's reuse in the House of Marcus Lucretius. Hip-herms with floral decoration are not very common. In the Augustan temple of Apollo at the Palatine hill there were Danaids depicted as cloaked hip-herms. Hip-herms also appear in various wall paintings and silver vessels.¹⁰⁵

I.1.9 Dolphin with cupid and octopus (Figs. 24–25, Cat. 237) P20373 (former 2061).

Place of discovery: Garden (18) southwest corner, on the right as seen from the tablinum (24.4.1847).

Dimensions: p H 25.9; W 19.5.

Technique: Some use of drill, e.g. the spaces between the tentacles of the octopus and the left eye of the dolphin.

Marble: Carrara, white.

Decoration: No traces of original colour preserved.

Condition: The dolphin's tail was missing already by the time of the excavation, the cupid's upper body went missing between that and 1927. Repair work done in the 1960's (?) was removed during conservation in 2008. Modern stainless steel pin inside.

Bibliography: PAH II, 463: *Un delfino al quale manca la coda, cavalcato da un Amorino, privo del braccio sinistro, poggiante su di un polipo: la sua intera altezza compresovi la base, la cui figura rappresenta un parallelepipedo, e di pal. 1 e tre decimi*; Panofka 1847, 133: *un Amore portato da un delfino* (only one mentioned);

Falkener 1852, 78: ...each side of which are Cupids riding on dolphins, which are feeding on polypi; Bechi 1852, 12; Niccolini 1854, 17: È due volte con pochissima varietà ripetuto il gruppo di un delfino che addenta un polipo, per difendere un Amorino dalle branche di quel vorace animale; Minervini 1855, 56; Breton 1855, 306; Fiorelli 1875, 393–394: only one mentioned; Döhl 1976 I, 52; Jashemski 1979, 42–43; Dwyer 1982, 42:viii, pl. X, fig. 34; Appleton 1987, 44 (no. 48); Jashemski 1993, 232; King 2002, 419, Kuivalainen 2008, 135.

Description and comments: A dolphin rescues a cupid from an octopus. The dolphin's head is turned downwards, and tail upwards, as it struggles with an octopus, whose one tentacle goes over the dolphin's rostrum (snout) and another over the melon (forehead); the body of the dolphin is fastened to a rugged high stone, by the belly and originally also near the tail. One of the octopus's tentacles encircles the cupid's left calf. Cupid sits on the dolphin's left pectoral fin; his right hand holds the

made herms with carved drapery. Farrar 2000, 122.

¹⁰⁵ Examples of Bacchic hip-herms are e.g. those depicted on Gallic silver cups, Avisseau-Broustet – Colonna – Lapatin 2014, 40–43. – The usual protome herms with floral columns were discovered in the garden of the house VI 15, 1 (Casa dei Vettii).



Fig. 24. Detail, Alma-Tadema's collection. (Cadbury Research Library, University of Birmingham.)

octopus's tentacle, while trying to draw back from the attacker; his head is turned downwards and to the left; there are folds in his stomach and left foot. The dolphin's dorsal fin is almost non-existent, as in the other sculpted group from this house. In the wall painting of the *aedicula* it is rendered in larger scale. The workmanship is of higher quality and more detailed than in the counterpart No. 10. They obviously come from the same workshop, perhaps even by the same hand.

Several statues in Pompeii depict a dolphin rescuing a cupid from an octopus. A group of four marble statuettes with cupids and dolphins were discovered from the house I 9, 13 (Casa di Cerere).¹⁰⁶ There are also some bronze objects, e.g. from the house VI 14, 43 (Casa degli Scenziati), where there was an elaborate suspended lamp with a cupid, dolphin, and a big octopus.¹⁰⁷ Dolphins were Bacchic animals, and cupids were also part of the Bacchic entourage.¹⁰⁸ Dolphins were considered wise and friendly towards humans, potentially coming to their aid in the case of an attack, and in one case even helping a school boy travel from Baiae to Puteoli.¹⁰⁹

I.1.10 Dolphin with cupid and octopus (Figs. 26–27, Cat. 271)

P20374 (former 2058).

Place of discovery: Garden (18), northwest corner, on the left (22.5.1847).

Dimensions: p H 29.5; W 17.0.

Technique: Drill used copiously on the rock, the dolphin's mouth, and the spaces between the tentacles of the octopus and dolphin. Also on some details of the cupid, e.g. navel and mouth.

Marble: Carrara, white with some greyish veins.

Decoration: No traces of original colour preserved.



Fig. 25.

¹⁰⁶ In one of them a small cupid sits on the back of the dolphin, both legs on the same side: the left is stretched along the flank, and the right is folded. The left arm is holding the tail, and the right is touching the tentacle of the small octopus. In the other three statues there is no octopus. P 2083-4, 2084-4, 2096-4 and 2097.

¹⁰⁷ G. Finati in *MB* 16, tav. 6; Ruesch 1908, 369 (no. 1628).

¹⁰⁸ Appleton 1987, 166.

¹⁰⁹ Plin. *nat.* 9,24–32; Ridgway 1970, 89–92.



Fig. 26. Detail, Alma-Tadema's collection. (Cadbury Research Library, University of Birmingham.)

Condition: The dolphin's tail, as well as some of the octopus's tentacles, are broken, and the cupid's whole left arm and right forearm and left foot are missing. Some cracked parts were glued with epoxy resin mixed with micronized silica during conservation in 2008; modern stainless steel pin inside.

Bibliography: PAH II, 465: *Un Amorino che cavalca un delfino poggiante su d'un polipo, simile all' altro descritto nel giorno 24 aprile p. s.*; Panofka 1847, 133: *un Amore portato da un delfino* (only one mentioned); Falkener 1852, 78: ...each side of which

are Cupids riding on dolphins, which are feeding on polypi; Bechi 1852, 12; Niccolini 1854, 17: È due volte con pochissima varietà ripetuto il gruppo di un delfino che addenta un polipo, per difendere un Amorino dalle branche di quel vorace animale; Minervini 1855, 56; Breton 1855, 306; Fiorelli 1875, 393–394: only one mentioned; Döhl 1976 I, 53; Jashemski 1979, 42–43; Dwyer 1982, 42:ix; Appleton 1987, 43–44 (no. 47); Jashemski 1993, 232; King 2002, 419; Kuivalainen 2008, 135.

Description and comments: A dolphin rescues a cupid from an octopus, made of one piece of marble. The dolphin's head is turned downwards and tail upwards, as it struggles with an octopus whose one tentacle goes over the dolphin's rostrum (snout) and another over the melon (forehead); the body of the dolphin is fastened to a rugged high stone, near the tail and the belly. One of the octopus's tentacles grasps the cupid's left shin. Cupid sits on the dolphin's left pectoral fin; his right hand holds onto the dolphin's back; the slightly plump cupid has a clearly indicated waistline; his head is turned downwards towards the left, and his throat is not visible; mouth is grimacing, nose is flat, eyes are depicted as sockets, hair is slightly curly. The missing left arm might have been trying to push the octopus down. There are several variants of this group in Pompeii. The surviving portion of the cupid's face looks horrified, unlike in the more calm-looking parallel from the Casa di Cerere (I 9, 13).¹¹⁰

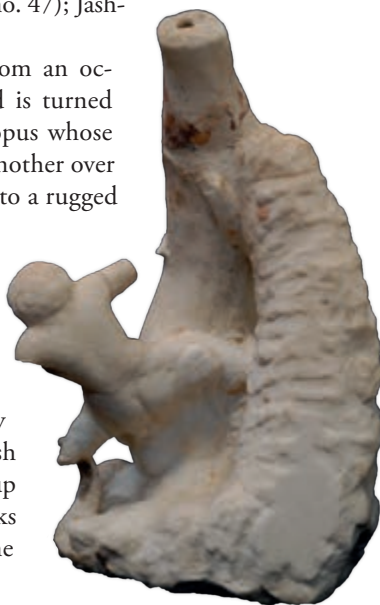

Fig. 27.

¹¹⁰ M. Pagano in *Rediscovering*, 266–268 (no. 188) gives inv. 8126; Dwyer 1982, pl. 47: 185.

I.1.11 Hare (Fig. 28, Cats. 239–241)

Lost (with no P number).

Place of discovery: Garden (18), in the middle of the west side, facing tablinum (15) (24.4.1847).

Dimensions: W base 26.4.¹¹¹

Technique: No information.

Marble: White.

Decoration: No information.

Condition: Ears not preserved when found. The statue was stolen soon after its discovery. It was missing at least in 1869.¹¹²

Bibliography: PAH II, 463: *un lepre accosciato, che mangia dell'uva: lo stesso è privo delle orecchie*; Panofka 1847, 133: one of the three hares in this garden – *l'uno con un grappolo d'uva*; Pancaldi 1848, 31; Falkener 1852, 77: a panther eating grapes; Bechi 1852, 12: *tre conigli*; Raoul-Rochette 1852, 302: *trois lièvres, l'un tenant une grappe de raisin*; Niccolini 1854, 17: *altro poco determinate quadrupede, che giudicar si potrebbe un cane*¹¹³; Minervini 1855, 56: same as Niccolini; Breton 1855, 306: *un troisième lapin* [no.] 50 *mangeant une grappe de raisin*; Fiorelli 1875, 393: *forse un cane*; Döhl 1976 I, 52; Jashemski 1979, 43: an animal that might be a dog; Kuivalainen 2008, 135–136.

Description and comments: This isolated animal has been hard to identify in the past because of the missing ears, and because there was only a single photograph of poor quality available: the animal is lying on the ground with all its legs under the body; in front of its head there is a big bunch of grapes; the head may be slightly turned towards the left. The most probable solution to its identity is a hare, due to the pose of the hind legs, which is



Fig. 28. Detail of the photo by R. Rive (Fig. 5). This is one of the few documents with the bunch of grapes by the hare's muzzle. (Getty Research Institute.)

¹¹¹ PAH II, 463: *un palmo*.

¹¹² Breton 1870, 396 note 1: “*Cette petite sculpture a maintenant disparu, volée sans doute par quelque voyageur peu scrupuleux. Ces vols seront toujours le plus grand obstacle à l’accomplissement du désir si souvent exprimé de voir laisser les objets au lieu même de leur découverte.*” Most pictures of the garden do not show this statue at all. There is a photo by James Graham 1862 ca. where it may possibly be present, but the foreground is not visible, only the upper part of Pan and satyr (No. 6). *Fotografi*, 54 (no. 14). It is not described, or in the plan by Overbeck (1856, 216, 219–220), but it is shown in his fig. 171. Fiorelli (1875, 393) mentions it vaguely as a dog, but it must have disappeared by that time.

¹¹³ Niccolini's depiction of a possible dog (tav. I, fig. 14) is not eating any grapes, and the figure seems to be more similar to the hares No 12. or No. 13, although it is not correctly depicted in any of them. Niccolini has perhaps combined the information about a dog or a panther with the other two.

typical of the animal.¹¹⁴ The suggestion that it is a panther or a dog goes against the whole theme of the garden decoration.¹¹⁵ The hare with a big bunch of grapes in front of its muzzle is a known subject in Pompeii, both in paintings and in a marble pinax.¹¹⁶ From Pompeii there also comes a hare with exceptionally long ears, but laid down along the back, with grapes held between the forelegs.¹¹⁷

Most Pompeian lagomorphic animal statues depict hares, which were both hunted and domesticated. They were kept for hunting purposes in *leporaria*, and also as pets. Being very fecund, rabbits were also erotic symbols.¹¹⁸

I.1.12 Hare (Figs. 29–31, Cats. 239–241)

P20369 (former 2063).

Place of discovery: Garden (18), south side.

Dimensions: H 10.5; W 20.7; plinth H 1.6, W 18.0, DPT 10.5; base H 8.8, W 20.8, DPT 17.7.

Technique: Drill used under the ears and in the open mouth. Some places under the ears, between the hind legs, and the terrain left rough.

Marble: White.

Decoration: No visible.

Condition: The ears and hind legs are now lost, but the pawns remain.

Bibliography: Panofka 1847, 133: one of the three hares in this garden; Pancaldi 1848, 31: *rane*; Falkener 1852, 78: a toad (?); Bechi 1852, 12: *tre conigli*; Niccolini 1854, 17: *due conigli, come sembra*¹¹⁹; Minervini 1855, 56; Breton 1855, 306; Fiorelli 1875, 393: *due conigli*; *Inventario* 209–210: un coniglio; Kaposy 1969, 50: *zwei kleine Hunde*; Jashemski 1979, 43; Dwyer 1982, 46–47:xix, pl. XIII, fig. 49: hare; Appleton 1987, 85 (no. 109): hare, with bunch of grapes at the forefeet; Jashemski 1993, 232: hare; King 2002, 410, 430: the pose is unnatural for a hare and on balance, attribution to dog is preferred; Kuivalainen 2008, 135–136.

Description and comments: A hare is standing with its head lowered between its forelegs; the hind-quarters are raised and hind legs stretched; the very long ears were originally attached to the back,



Fig. 29 (left). Niccolini 1854, pl. I, fig. 14. Fig. 30 (right). Detail, Alma-Tadema's collection. (Cadbury Research Library, University of Birmingham.)

¹¹⁴ There was a hare discovered without context in Pompeii (P 11754), however it was not eating grapes.

¹¹⁵ Panthers tend to have longer necks. Panther statues are also made of coloured stones, e.g. the two in the Farnese collection (MANN 6225 of red granite and 6223 of *pavonazzetto*). Dodero 2009, 68–69.

¹¹⁶ A pinax (MANN) e.g. Bacchetta 2006, 569 (no. R42), pl. LIII, fig. 2 and another (MANN 6620) p. 590 (no. S4), pl. LXI, fig. 3; the first one was published already in Pailler 1982, 818 (no. 167), pl. II, fig. 2; Kaposy 1969, 49 lists several hares eating grapes used as fountains, but the one in the Naples museum is cited by a wrong number. The other examples are in the Vatican or in Ostia.

¹¹⁷ Carrella 2008, 218 (no. E14) in *Marmora pompeiana*. Another hare with some different parallels are also listed on p. 90–91 (no. B24) in *Marmora pompeiana*.

¹¹⁸ King 2002, 431–432, 436–437.

¹¹⁹ Dwyer 1982, 46–47 cites this as a dog depicted by Niccolini. Thus, the information could be about the one described in No. 11. The animal was published after this picture was taken, and also later, looking even more like a dog. Reinach 1906–1930, vol. 2 (1909), 764 no. 7. – The drawing is quite far from the original.



Fig. 31.



Fig. 32.

now indicated only by a knob; the eyes are big; some hairs are clearly marked in the neck and under the tail; the hole in the mouth was used as a water spout. This statue was earlier confused with the previous No. 11, the hare eating grapes.¹²⁰ There are indeed some roundish objects, three small grapes (D 1.0–1.5 cm), in front of the hare, but not a big bunch of grapes. The position in the garden was also different.

Another hare with same pose was discovered in the Casa degli Amorini Dorati, now unfortunately also stolen.¹²¹

I.11.13 Hare (Figs. 32–33, Cats. 239–241)
P20368 (former 2057).

Place of discovery: Garden (18), side.

Dimensions: H 12.0; W 9.5 (forelegs), DPT 18.0; ancient base H 3.0, W 12.0, DPT 17.5; modern base H 9.0, W 17.5, DPT 20.0.

Technique: A drill was used between the fore legs and in the opening of the mouth.

Marble: White.

Decoration: On the left hind leg, traces of bluish and brownish pigments.

Condition: The ears are broken, as is part of the tail, and small pieces of the neck.

Bibliography: Panofka 1847, 133: *tre lepri*; Pancaldi 1848, 31: *rane*; Falkener 1852, 78: a toad (?); Bechi 1852, 12: *tre conigli*; Niccolini 1854, 17: *due conigli, come sembra*; Minervini 1855, 56; Breton 1855, 306; Fiorelli 1875, 393: *due conigli*; *Inventario* 207–208: *un coniglio*; Kapossy 1969, 50: *zwei kleine Hunde*; Jashemski 1979, 43; Dwyer 1982, 47:xx, pl. XIII, fig. 50: hare; Appleton 1987, 86 (no. 110): hare; Jashemski 1993, 232: hare; King 2002, 410, 430, see above No. 12; Kuivalainen 2008, 135–136.

Description and comments: The hare and the original base were made of one piece of marble. The hare is lying on its forelegs, with its hind quarters raised and both legs

wide open; the toes and the spine are clearly marked; the neck is ringed; the short muzzle is depicted only by the opening for the spout, without any nose; the very long ears were originally attached to the back, now indicated only by a knob; the eyes are big.

¹²⁰ Dwyer 1982, 47. This statue is mentioned as “the hare eating grapes” described by Falkener 1852.

¹²¹ Appleton 1987, 86 (no. 111). The ears were missing here as well. King 2002, 410 describes it as a dog, probably a house or lap dog.

Nos. 12 and 13 were both found near the round basin in the garden; the mouths were designed as water spouts and thus used as fountain pieces.

I.1.14 Deer (Figs. 34–35, Cat. 253)

P20466 (not in the former inventory).

Place of discovery: Garden (18), southeast side of the basin (29.4.1847).

Dimensions: H 21.0, W 33.0, DPT 19.0; plinth W 36.6, DPT 22.0; base H 3.0, W 40.0, DPT 25.0.

Technique: High-quality workmanship. A drill was used for the holes attaching the antlers, and for the hole on the top of the head, and the hole in front of the right hind leg in the terrain. The body is well polished.

Marble: White.

Decoration: None, except antlers made of bronze.

Condition: Fractures in the base with modern filling; the animal is intact, the antlers are missing.

Bibliography: PAH II, 463–464: *Una cerva di lunghezza pal. 1 ½. e di altezza con la base 3/5 di pal. priva delle corna.*; Panofka 1847, 133; Quaranta 1847, 74; Pancaldi 1848, 31; Falkener 1852, 78: a hind; Bechi 1852, 12: *un cavallo*; Niccolini 1854, 17: *una piccola cervetta*; Minervini 1855, 56; Breton 1855, 306: *un cheval couché*; Fiorelli 1875, 393: *una piccola cerva*; Döhl 1976 I, 53; Jashemski 1979, 43; Dwyer 1982, 46: xviii, pl. XIII, fig. 48: deer; Appleton 1987, 29–30 (no. 31): deer; Jashemski 1993, 232; King 2002, 418: red deer (*Cervus elaphus*); Stefani 2011, 201 (no. 184); Kuivalainen 2008, 136–137.

Description and comments: The quasi-oval plinth is attached to the rectangular base. A small circle was carved in front of the hind legs in the base. The deer is lying on its left side, the plinth and animal are made of one piece of marble. The head is turned towards the right, the antlers were attached below the small ears; another hole was made on the top of the head; there are some well-defined details such as the folds of the skin in the neck. Deer are a well-known subject in Roman gardens, and are also depicted in wall paintings.¹²²



Fig. 34.



Fig. 34.



Fig. 35.

¹²² King 2002, 417–419.

I.1.15 Cow (Figs. 36–37, Cat. 255)

P20467 (former 2065).

Place of discovery: Garden (18), south of the basin (4.5.1847).*Dimensions:* Animal H 13.9; W 21.5, DPT 8.0; base H 3.0, W30.0, DPT 16.00.*Technique:* Ears made of separate marble pieces have been joined to the body, separate horns were probably made of iron, or separate pieces attached with iron.¹²³ A drill was used for details, such as on the muzzle to shape it into a spout, and in the details that separate the hooves.*Marble:* The animal is made of white transparent, probably Greek marble and greener than Parian with yellowish veins.*Decoration:* Separate ears and horns, otherwise none.*Condition:* Surface was originally damaged by lichen, both ears and horns are missing. The tail is broken in the upper part.*Bibliography:* PAH II, 464: *un torello*; Panofka 1847, 133: *una vacca giacente*; Quaranta 1847, 74: *Un torello*; Pancaldi 1848, 31; Falkener 1852, 78: a cow; Bechi 1852, 12 *una vacca*; Niccolini 1854, 17: *una vacca*; Minervini 1855, 56; Breton 1855, 306; Fiorelli 1875, 393: *una vacca giacente*; *Inventario* 209–210: *una vacca*; Kapossy 1969, 51, 60¹²⁴; Döhl 1976 I, 53; Jashemski 1979, 43; Dwyer 1982, 46:xvii, pl. XIII, fig. 47; Appleton 1987, 16 (no. 16); Jashemski 1993, 232; Kuivalainen 2008, 136.*Description and comments:* The rectangular base is modern whitish marble with grey veins. The cow is laying on a circular small plinth made of the same piece of marble as the animal. It is resting the weight of its body on its right side, and the head is turned to the left, seemingly ruminating. It is of a high quality workmanship with expressive eyes. Small folds of the skin are visible in the chest and on the left hind leg. Another marble cow used as a fountain is in the Naples museum, but with unknown provenience.¹²⁵ In Pompeii, a fragmentary cow was discovered in the atrium of the Casa*Figs. 36–37.*¹²³ Information given by the conservator Christina Danieli 17.3.2008.¹²⁴ Kapossy 1969, 60 also lists another cow, which may actually refer to the deer.¹²⁵ Kapossy 1969, 51. The inventory no. 212 is problematic, most probably from one of the previous inventories; Appleton 1987, 14–16 (no. 15): H with base is 21.0, W 33.0, so it is a little larger statue. There are also some bronze cows, one probably from Herculaneum, but if not from Pompeii, Appleton 1987, 13 (no. 14).

di Gavius Rufus (VII 2,16), but it is now lost.¹²⁶ A cow used as a fountain spout is a rare object. The miniature size is understandable because of the small size of the garden, and was usual also elsewhere in Pompeii.

I.1.16 Duck (Fig. 38, Cat 251)

P20377 (former 2053).

Place of discovery: Garden (18), northeast of the basin (29.4.1847).

Dimensions: Animal with base H 37.0; L 52.0; H base 12.5, W base 6.5, DPT base 4.5.

Technique: Some tool marks visible on the back, possible use of claw chisel.

Marble: White with greyish veins, probably Carrara.

Decoration: No traces of colour visible, though some of the original surface is in good condition.

Condition: Underbody corroded, stain under the neck caused by an iron pin. The broken neck was restored in 2008 by adding a steel pin and filling the gaps with dentist's gypsum and mortar. Only about half of the bill is preserved.

Bibliography: PAH II, 463: *Un'anitra di lunghezza pal. 1 1/2, e di altezza con la base pal. 1 priva di piedi.*; Panofka 1847, 133, *un oca*; Quaranta 1847, 74; Pancaldi 1848, 31; Falkener 1852, 78: a goose; Bechi 1852, 12: *un' oca*; Niccolini 1854, 17: *un' oca*; Minervini 1855, 56: *un' oca*; Breton 1855, 306: *un canard*; Fiorelli 1875, 393: *un' oca*; *Inventario* 207–208: *un'oca*; Döhl 1976 I, 52; Jashemski 1979, 43: duck (or goose); Dwyer 1982, 45–46:xvi, pl. XII, fig. 46: a duck; Appleton 1987, 57–58 (no. 66); Jashemski 1993, 232: duck; Watson 2002, 364–365: a duck; Kuivalainen 2008, 136.

Description and comments: The bird is a domestic duck represented almost in natural size.¹²⁷ It was discovered without feet, and was later attached to a modern pillar. The body is asymmetric, the head is slightly turned to the right, the closed wings are clearly marked with feathers in relief. The roughly finished underbody may point to the bird's original stance as lying in the grass, which is also suggested by the place of discovery next to the circular basin.



Fig. 38.

¹²⁶ Appleton 1987, 16 (no. 17).

¹²⁷ This marble statue representing a waterfowl (*Anseriformes sp.*) is identifiable as a Domestic Duck (*Anas platyrhynchos domesticus*) by the shape and relative size of the bird, in particular by the characteristic head and bill. The shape and relative sizes of the head and bill, with vague remains probably representing the nostrils relatively close to the head, as well as the length and position of the primaries of the wing in relation to the tail, exclude the identification as a Domestic Goose (*Anser anser domesticus*), and also as an Egyptian Goose (*Alopochen aegyptiacus*), despite the more duck-like bill of the latter species. The identification as a 'duck' by Dwyer 1982, 45–46 and Watson 2002, 364–365 s.v. '*Anas platyrhynchos, Anas sp.*' is correct, despite the somewhat inaccurate definition as a "small statuette" by Watson. Hence, here is corrected the previous erroneous identification as an Egyptian Goose suggested in *Domus Pompeiana* and repeated in Tammisto – Wassholm 2016, 261. I thank my colleague Antero Tammisto for his perseverance in analysing the bird.

I.1.17 Ibis (Figs. 39–41, Cat. 256)

P20376 (former 2055).

Place of discovery: Garden (18), north of the basin (26.4.1847).¹²⁸*Dimensions:* H 11.5; W 8.7, L 26.1.*Technique:* Good quality workmanship. Two holes in the roughly finished underbody for inserting the legs, which were spread wide apart.*Marble:* White Carrara with parallel grey veins.*Decoration:* Orange colour is iron oxide.*Condition:* It was discovered in several pieces. Tail broken, legs and head missing. Now attached to a small pillar.*Bibliography:* PAH II, 463: *un uccello aquatico, forse un ibi, in più pezzi*; Quaranta 1847, 73; Panofka 1847, 133: *due Ibis*; Pancaldi 1848, 31; Falkener 1852, 78: two birds; Bechi 1852, 12: *due ibis*; Niccolini 1854, 17: *due augelli a lungo becco somiglianti nella forma all' ibis*; Minervini 1855, 56; Breton 1855, 306: *deux ibis*; Fiorelli 1875, 393: *due ibis*; Döhl 1976 I, 53; Jashemski 1979, 43: two birds that look like ibises; Dwyer 1982, 45:xiv, pl. XII, fig. 44; Appleton 1987, 106 (no. 135); Jashemski 1993, 232; Watson 2002, 391: glossy ibis (*Plegadis falcinellus*) or more probably sacred ibis (*Threskiornis aethiopicus*) 397; Kuivalainen 2008, 136.*Description and comments:* Long groove across the back (spine). Holes for the separate legs. Two possible parallels come from the temple of Isis, which suits very well the possible cultic theme. A statue of an ibis attacking a serpent was found in another Pompeian house.¹²⁹ Also see comments below, for No. 18.

Fig. 40. Detail. R. Rive's photo ca. 1859 shows a separate head. (Getty Research Institute.)

I.1.18 Ibis (Fig. 42, Cat. 288)

P20378 (former 2064).

Place of discovery: Garden (18), south of the basin (4.5.1847).¹³⁰*Dimensions:* H 8.2, W 11.7, L 24.6.*Technique:* Simple workmanship, originally details painted and added to the body.*Marble:* White.*Decoration:* No traces of colour.*Condition:* Head and legs missing. Attached to a modern base, which prevents properly observing the underbody, with holes for the legs.

Fig. 39. Niccolini 1854, pl. 1, no. 12.

¹²⁸ I would say that this ibis from the northern side of the garden was discovered at this date, because it was in several parts; the head may have been found as well, as it is seen in old pictures. The next statue discovered which can be clearly located was the satyr No. 7.

¹²⁹ Watson 2002, 391 & 397; attacking the serpent comes from house II 2, 2.5, P 2899. The ibises from the temple of Isis, MANN 765 and 766 in the Egyptian collection, have heads, necks and legs made of bronze, body of marble.

¹³⁰ The ibis discovered at this time was found together with the cow (*torello* in PAH).



Fig. 41.



Fig. 42.

Bibliography: PAH II, 464: *un ibis*; Panofka 1847, 133: *due Ibis*; Quaranta 1847, 74: *un uccello*; Pancaldi 1848, 31; Falkener 1852, 78: two birds; Bechi 1852, 12: *due ibis*; Niccolini 1854, 17: *due augelli a lungo becco somiglianti nella forma all' ibis*; Minervini 1855, 56; Breton 1855, 306; Fiorelli 1875, 393: *due ibis*; Döhl 1976 I, 52; Jashemski 1979, 43: two birds that look like ibises; Dwyer 1982, 45:xv, pl. XII, fig. 45; Appleton 1987, 106–107 (no. 136); Jashemski 1993, 232; Watson 2002, 391: glossy ibis (*Plegadis falcinellus*) or more probably sacred ibis (*Threskiornis aethiopicus*) 397, Kuivalainen 2008, 136.

Description and comments: What is left of these two ibises is a characteristically smooth body. Both of them must have had painted details, because of the simplicity of their form. They were positioned symmetrically nearer the eastern side of the basin, towards the tablinum.

1.1.19 Head of Bacchus (Figs. 43, Cat. 94)

MANN 6441 (San Giorgio inv. 1626).

Place of discovery: Cubiculum and closet under stairs¹³¹ (24.3.1847).

Dimensions: H 16.0.

Technique: A drill was used on the berries of the ivy, and some of the curls. The backside was left rough.

Marble: Rosso antico.

Decoration: No traces.

Condition: Intact.

Bibliography: PAH II, 460: *una testa Bacchica*; Niccolini 1854, 21: *una bacchica testa di rosso antico*; Minervini 1855, 86; Döhl 1976 I, 52; Dwyer 1982, 25–26:i, pl. III, fig. 7–8: Bacchus¹³²; D'Acunto 2008, 164–166 in *Marmora pompeiana* (no. D 06): *Dioniso giovane*.

¹³¹ Dwyer 1982, 25: either in room 3 or 4.

¹³² Dwyer 1982, 26; Falkener 1852, 51, writes about a cup made of *rosso antico*, and the error is repeated by Niccolini and Minervini, who present both objects. Niccolini uses Minervini's text in the list of objects.

Description and comments: The quadrangle shape of the bust justifies the interpretation as a part of a herm. The face is broad and masculine, though San Giorgio inv. mentions the head as “*una baccante*”. There are shallow rectangular cuttings for the attachment of the bosses (rudimentary arms). He has a large mouth, straight nose, and large eyes with clearly marked lids. The hair is parted in the middle. On the top of the head there are clusters of berries (*korymboi*), and both ears seem to be decorated with additional clusters. Long tresses fall to the muscular chest.

I.1.20 Mask¹³³ (Figs. 44, Cat. 278)

MANN possibly 6610 (San Giorgio inv. 1629 is lost, given also inv. 456 but possibly inv. 656).

Place of discovery: Garden (18), south side (25.5.1847).

Dimensions: H 27.3; W 18.0; Th max 10.0.

Technique: Ample use of drill. The concave mask is perforated at several points: mouth, eyes, behind the ears twice on both sides. High quality workmanship.

Marble: White.

Decoration: Some traces of colour.

Condition: Almost intact.

Bibliography: PAH II, 466: *una testa virile della grandezza del vero con corti capelli, con mustacchi, con orecchie faunine e colla bocca aperta, certamente per getto*; Falkener 1852, 73: A marble mask of the head of a Faun, with short hair, moustaches, long ears, and open mouth, probably formed one of these suspended decorations, if, indeed, it did not serve as the ornament of a fountain on the upper; Döhl 1976 I, 53; Dwyer 1981, 272 (no. 43) but more likely 281 (no. 114); Dwyer 1982, 40:vi; Carrella 2008 in *Marmora pompeiana*, 254–255 (no. E82): Pan.

Description and comments: The item corresponding to the general description is a mask with unknown provenience from Pompeii.¹³⁴ Although it is not certain, it is probable that MANN 6610 is the mask found in the House of Marcus Lucretius. A masculine face with thick hair with volute-like curls, also in the beard and moustache. The large smiling mouth is open, the nose is strong and broad, the small eyes have a sharp look, the eyebrows are drawn together, the tapering ears have big lobes.



Figs. 43.



Fig. 44.

¹³³ Farrar 2000, 125–127 defines the masks as *oscilla*, but the *pinakes* as standing on marble posts, otherwise rectangular *oscilla*. – The exact meaning of the two words is not quite clear.

¹³⁴ I owe this information to Ria Berg, who kindly took the trouble to search in the store rooms in Naples. According to her the San Giorgio no. proposed by Dwyer for the faun of the House of Marcus Lucretius is false because this number 1629 refers to a relief head as “*la testa di un faunetto con bocca aperta poggiata contro un masso a forma di pilastro*”. *Registro delle Immisioni* has a number San Giorgio inv. 456. The number 456 could be mistaken for 656, which has a description more similar to the PAH entry: “*maschera di satiro con corna e barba folta, occhi e bocca forata. Alta palmo uno ed oncia una, per once sette*”.

There are clusters of ivy berries over the temples and under the ears. There are small goat's horns on the top of the head.

There are masks nearly similar to this one, the best example comes from Herculaneum (MANN 3490).¹³⁵

I.1.21 Oscillum (Figs. 45–46, Cat 289)

MANN 6648 (San Giorgio inv. 1627).

Place of discovery: Garden (18) north side (26.4.1847).

Dimensions: D 30.8; DPT 2.5.

Technique: Relatively high relief with careful workmanship. A drill was possibly used for the eyes on the side A. Holes for hanging in upper and lower edges.

Marble: White.

Decoration: Traces of colours (mainly yellow and red) on both sides.

Condition: Indentations and cracks on the edge. Greyish dirt.

Bibliography: PAH II, 463: *Un disco per intercolunnio, che da un lato ritrae il sacrificio d'un vitello, e dall' altro una figura virile barbata, che offre una cesta ripiena innanzi ad un'ara, su cui è acceso il fuoco, il suo diametro e di pal. 1 1/5; Quaranta 1847, 73; Falkener 1852, 73: ...the fourth circular, 15 ins. in diameter, with a sacrifice of a calf on one side, and the other a bearded figure, presenting a cista full of gifts to an altar; Niccolini 1854, 21–22¹³⁶; Minervini 1855, 86: *Un uomo vigoroso con succinto gonnellino di giallo colore, il quale tiene colla sinistra la testa di un nereggiante vitellino, e colla destra gl'immerge nella gola il coltello. Innanzi è un Satiro barbato con coda, che tiene il vaso destinato a raccogliere il sangue della vittima, ...una irregolare costruzione, sopra di cui scorgesi una enorme testa di cornuto Pane, tinta di rosso, destinata certamente ad indicare una fonte. In mezzo è un panciuto e nudo Sileno con rossa barba, e con breve panno azzurro, che ne ricopre porzione del corpo, il quale tien con ambe le mani una cesta colma di frutta, offrendola innanzi ad un' ara accesa, da cui sorger si mirala fiamma di rosso.* – He links the sacrifice to the Attic festival of *Buphonia* and Bacchic mysteries; Albert 1881, 199 (no. 18); Döhl 1976 I, 52; Dwyer 1981, 272 (no. 44); Dwyer 1982, 38–39:i, pl. VII, fig. 24 & 25; Bacchetta 2006, 447 (no. T112), pl. XVII, fig. 4; D'Acunto 2008, 166 in *Marmora pompeiana* (no. D 07).*

Description and comments: This is a circular disk with both sides decorated. Inside a simple frame



Fig. 45. Side A.

¹³⁵ Mastroberto in *Domus – viridaria – horti picti* 1992, 119–120 (no. 37). Another mask is in a statue depicting a cupid holding Pan's head from Pompeii IX 7,20 (MANN 114595), published e.g. Dwyer 1982, 76–77:xxii. Masks can be also of different type e.g. a satyr mask from Cosa has a ruder character compared to these more detailed works of art, Taylor 2005, 86.

¹³⁶ Is the same as the following Minervini.



Fig. 46. Side B.

is a satyr mask on top of a rocky formation. The bearded mask has an open mouth and two horns pointing forward. The composition is relatively simple compared to parallel oscilla, which are overflowing with paraphernalia.¹³⁹

I.1.22 Oscillum (Figs. 47–48, Cat. 294)

MANN 6663 (San Giorgio inv. 1628).

Place of discovery: Garden (18), possibly east side (19.5.1847).

Dimensions: H 23.0; H to the central feature 16.0; W 30.7; DPT 2.5.

Technique: Quite simple workmanship with only few details. The lower edge curves towards side B.
Marble: White.

Decoration: Traces of colours (yellow, red and black) on both sides.

Condition: Two parts missing: the central feature and one terminal. Fractures and some brownish stains.

Bibliography: PAH II, 465: *un scudo ... a forma di pelta lunata*; Falkener 1852, 73: *two* resembling the Amazonian pelta; Niccolini 1854, 21: *alcuni scudi a guise di pelta lunata... una testa satiresca... pochi ornamenti graffiti*; Minervini 1855, 86; Döhl 1976 I, 53; Dwyer 1981, 272 (no. 45); Dwyer 1982, 39:ii, pl. VIII, fig. 26 & 27; Bacchetta 2006, 524–525 (no. P42), pl. XXXVIII, fig. 3; D'Acunto 2008, 167 in *Marmora pompeiana* (no. D 08).

Description and comments: An oscillum in the shape of a pelta. The remaining terminal is customarily griffin-headed. Side A depicts a central bust in three-quarter profile facing to the right, the head of bearded satyr, with longish undulating hair with upright front lock, moustache, large strong

on side A, a pig is being sacrificed.¹³⁷ The weight of the pig's body is on its hind legs. Its snout is being held upwards by the sacrificial attendant's left hand. He is holding the animal between his legs. He is bending over the animal, and pushes the knife with his right into the animal's throat. He wears a loin cloth. The other attendant on the left is a bearded, naked, muscular elderly satyr who concentrates on keeping the blood bowl in his hands. The composition is placed on the bare ground, marked by a simple straight line. Inside a simple frame on side B there is another sacrificial scene, with a bearded elderly man standing in the middle. He holds a basket full of fruit and cones with his left hand, and is picking at the fruit with his right hand.¹³⁸ He wears a loin cloth under his big belly. On his right there is an altar with red flames, and on his left there

¹³⁷ The animal is clearly a pig, not a calf as in e.g. Dwyer 1981, 272 or Dwyer 1982, 38. There is a good parallel from Pompeii: a wall painting from a lararium in insula VIII, 2 (MANN 8905), which shows a sacrificial pig being led by an attendant. According to Varro, a pig was the most common animal for private sacrifices, *rust.* 2.4.9.

¹³⁸ Fruits were widely offered as *praemetium*, or tithes of the harvest. *Fest.* p. 319 and p. 235.

¹³⁹ *Domus – viridaria – horti picti*, nos. 13, 15, 34.

nose, bulbous eyes and huge eyebrows, and tapering ear lobes. In front of/underneath him, on the right, there are one or two staffs, probably a thyrsus.¹⁴⁰ Side B depicts a leather bag, or a hemispherical basket, with three round objects.¹⁴¹ Dwyer has identified the peltas (Nos. 22–24) and the pinax (No. 26) as being made by the same local hand.¹⁴² They might have been inspired by an Apollonian context as well, but Dwyer believed that the griffin pelta could have had Dionysiac religious meaning.¹⁴³

I.1.23 Oscillum (Figs. 49–50, Cat. 320) MANN 6669 (San Giorgio inv. unknown).

Place of discovery: possibly in the garden (18).

Dimensions: H 22.0; H to the central feature 16.0; W 30.0; DPT 1.7.

Technique: Quite simple workmanship with only few details. The central feature may have been made of a separate piece of marble, which left a small vertical groove.

Marble: White.

Decoration: Traces of yellowish colour on both sides.

Condition: Fractured into two pieces, parts of one edge and the central feature are missing. One beak is lost.

Bibliography: Falkener 1852, 73: *two* resembling the Amazonian pelta; Minervini 1855, 86: *alcuni scudi a guise di pelta lunata*; Dwyer 1981, 272–273 (no. 47), pl. 106, fig. 1 & 2; Bacchetta 2006,



Fig. 47. Side A.



Fig. 48. Side A.

¹⁴⁰ A thyrsus is connected with a satyr in profile to the right in another pelta MANN 6661, Inserra in *Marmora pompeiana* 45 (no. A 25). About the object in front of the satyr, see also No. 24; a thyrsus is also shown in a pinax in the Ashmolean museum in Oxford, see Hundsalsz 1987, 235–236 no. K 144.

¹⁴¹ Drummond – Nelson 1994, 80: "In the year 100...fruit and vegetables were shipped in leather bags." The idea of there being three apples is not justified, even possibly mythological ones as proposed by Dwyer 1982, 39. – A basket of the same shape, with clearly marked wicker, is depicted in Bacchetta 2006, 661, tav. 42, 4. That is why our leather bag may rather be a basket, which has now lost its painted wicker. Another is 518 no. P26 (tav. 35,4); Cullin-Mingaud 2010, 82–84.

¹⁴² Dwyer 1981, 291, 293: "Of the entire collection of reliefs from the House of Marcus Lucretius, four are by the same hand. It is likely that these were purchased as asset from a single workshop, or from some merchant who represented that workshop. No other works by the same hand have as yet been identified." He attributed these to the "local hand no. 1".

¹⁴³ Dwyer 1981, 253–255; Thompson 1968, 48–52; Lippold 1909, 492–500.

525–526 (no. P44), pl. XXXVIII, fig. 5; D’Acunto 2008, 167–168 in *Marmora pompeiana* (no. D 09).

Description and comments: An oscillum in the shape of a pelta. Terminals are griffin-headed, as was usual. On side A, in an irregular field, is a beardless satyr in profile to the right. The chin is square, the mouth is wide open; he has a short hooked nose, small eyes, and thick wavy hair with an upright front lock. The big earlobe is not pointed. On side B, the field resembles the leather bag or basket in No. 22. To the right, a dolphin is swimming in calm waves. There is no dorsal fin. Dwyer relied upon the similarity of this oscillum to those certainly found in the House of Marcus Lucretius for his attribution. There is confusion in the archives in Naples as to its identification.¹⁴⁴

I.1.24 Oscillum (Figs. 51–52, Cat. 321) MANN s.n. (San Giorgio inv. unknown).

Place of discovery: Garden (18)?

Dimensions: H 15.7; W 23.0; DPT 3.1.

Technique: Quite simple workmanship with only few details. Very wide marks of the chisel on the ground.

Marble: White.

Decoration: Minor traces of colour remaining, e.g. red in the hair.

Condition: Both ends, with their terminals, and the central feature are missing; only the central field with its simple border remain. The lower edge is fractured on side B.

Bibliography: Falkener 1852, 73: *two* resembling the Amazonian pelta; Minervini 1855, 86: *alcuni scudi a guise di pelta lunata*; Dwyer 1981, 272 (no. 46); Dwyer 1982, 39:iii, pl. VIII, fig. 28 & 29; Bacchetta 2006, 525 (no. P43), pl. XXXVIII, fig. 3.

Description and comments: An oscillum in the shape of a pelta. Side A has a field shaped like a leather bag or a basket, as in Nos. 22 and 23. A beardless satyr is depicted in profile to the right. He has a very strong protruding chin, very open mouth and puckered/pouting lips. The nose is long, ears



Fig. 49. Side A.



Fig. 50. Side B. In a museum photo from 1927 the pelta is better preserved, with its central feature and more of the lower left edge preserved.

¹⁴⁴ Dwyer 1981, 271 note 82. D’Acunto 2008, 167 does not have any doubts about its origin.

exceptionally pointed. He has small eyes and thick wavy hair with an upright front lock. The curving line in front of the face has been interpreted as the edge of a tympanon,¹⁴⁵ for which the edge is too narrow in my mind. As it covers the whole length of the field, it seems rather to be the curving arm of either a barbiton or a lyre.¹⁴⁶ Consequently, the open mouth of the satyr would mean that he is singing, and is accompanying himself with the instrument. Side B also has a field shaped like a leather bag or a basket, as in Nos. 22 and 23. Depicted therein is a *syrinx* and a *pedum*, of which only the top part is visible.¹⁴⁷ The two musical instruments complete the picture of the singing satyr on side A.

I.1.25 Oscillum (pelta) (Cat.302)

MANN s.n. (San Giorgio inv. 1632)
lost.

Place of discovery: Garden (18), possibly south side (8.6.1847).

Dimensions: H appr. 31.0.

Technique: Not known.

Marble: White.

Decoration: Not known.

Condition: Broken; three parts were found, but some were already missing when excavated.

Bibliography: PAH II, 466: *uno scudo per intercolunnio a forma di pelta lunata in tre frammenti*; Falkener 1852, 73: *two* resembling the Amazonian pelta; Niccolini 1854, 21: *una comica maschera a destra, ed innanzi un corno rovesciato: all' opposto lato un ramo con tre fiori*; Minervini 1855, 86; Döhl 1976 I, 53; Dwyer 1982, 39–40:iv; Bacchetta 2006, 525 (no. P45).

Description and comments: According to earlier reports, side A depicts a comic mask, side B an ornament composed of three flowers. Both subjects appear frequently in pelta shaped oscilla.



Fig. 51. Side A.



Fig. 52. Side B.

¹⁴⁵ Dwyer 1982, 39; Bacchetta 2006, 525, 537–538 nos. P 76, P 77. The indefinite object is usually interpreted as a tympanon.

¹⁴⁶ Barbiton was more favoured by the Romans than by the Greeks.

¹⁴⁷ The Syrinx could also be a decorative oscillum on its own, e.g. *Domus – viridaria – horti picti*, no. 21.

I.1.26 Pinax (Figs. 53–55, Cat. 238)

MANN s.n. (San Giorgio inv. 1630).

Place of discovery: Garden (18) (25.5.1847).

Dimensions: H p. 16.0; W 39.2; DPT 2.0.

Technique: Quite simple workmanship but more detailed than the peltae. Drill used.

Marble: White.

Decoration: Traces of colour, e.g. red on the hair of the maenad.

Condition: Fragmented, two joining parts, approximately 60% of the work remains. On side B there are several small cavities on both boards on the short sides, and in the image field two sets of horizontal lines, one of ten holes above the first dolphin, and another of four holes above the second dolphin. Some modern restorations.

Bibliography: PAH II, 466: *due frammenti di scudo di forma quadrata per l'intercolunnio*; Quaranta 1847, 74: *due frammenti di scudo di forma quadrata per intercolunnio*; Falkener 1852, 73: one of a square form, broken; Döhl 1976 I, 53; Dwyer 1981, 273 (no. 48); Dwyer 1982, 40:v, pl. IX, fig. 30 & 31; Cain 1988, 202 (no. 53); Bacchetta 2006, 565–567, pl. LII, fig. 1; D'Acunto 2008, 168 in *Marmora pompeiana* (no. D 10).

Description and comments: This is a rectangular pinax. On side A, a field with a pronounced border; two heads are depicted in profile facing to the right. On the right, a bearded satyr with his mouth shut, a long nose, small eye, and thick wavy hair with curvy front lock, and horns. Slightly in front of him on the left hand side is a maenad with wavy hair and conical Phrygian cap, with a tip with a knot askew to the right. On side B, two dolphins are in profile facing to the right. The foremost dolphin, on the right side, is depicted with melon (forehead) and eye, thin dorsal fin, and tail flukes. Of the other dolphin, only parts of the tail flukes and the dorsal fin remain. The regular arrangement of the small holes may indicate that the pinax was attached to a wooden frame, partially obscuring the picture on side B, or else e.g. hanging garlands were fastened to them, as is known from wall paintings.¹⁴⁸



Fig. 53. Side A.



Fig. 54. Side B.

¹⁴⁸ Jashemski 1993, 392.

I.1.27 Silenus (Cat. 13)

MANN or P, now lost. *Registro delle immissioni* 22.2.1847 lists several statues for the museum, but this one with the addition to remain in Pompeii.

Place of discovery: atrium (2), in front of the tablinum, possibly fallen down from the first floor¹⁴⁹ (29.3.1847).

Dimensions: H ca. 80.0.¹⁵⁰

Technique: Not known.

Marble: White?

Decoration: Not known.

Condition: The head, right hand, and right foot were lost when discovered.

Bibliography: PAH II, 460: *Una statuetta frammentata mancante della testa, della mano destra, e del piede destro. La medesima tiene sulla coscia sinistra forse una otre: la sua intera altezza compresovi la testa e la base, ch'è di figura circolare, è di circa pal. 3; come pure altri piccoli pezzi di lastre frammentate;* Quaranta 1847, 72: *Una statuette rotta...Essa ha sulla coscia sinistra come un otre.*; Falkener 1852, 43: a marble statue, 2 feet 7 inches high, the head, right hand, and right foot of which were missing, might have served as the ornament of the fountain, as it holds a wine-skin on its left thigh, and might have been cast aside on account of its dilapidated condition when found, 70: the statue of a man with bagpipe, and 2 ft. 8 in. in height; Niccolini 1854, 3; Döhl 1976 I, 52 and II, 143; Dwyer 1982, 24–25:i.

Description and comments: This Silenus was a little bigger than the more complete No. 1 from the niche. Döhl suggested that it could have been its predecessor, from before the earthquake.¹⁵¹ Dwyer supported Falkener's first suggestion, that it might have been used as a silen fountain in the atrium.¹⁵²

I.1.28 Tree trunk (Cat. 45)

MANN or P, now lost.

Place of discovery: atrium (2), possibly fallen down from the first floor, or even from an upper garden¹⁵³ (10.4.1847).

Dimensions: Not known.

Technique: Not known.

Marble: White?

Decoration: Not known.

Condition: Fragmented detail only.

Bibliography: PAH II, 461: *un tronco di albero per sostegno di statuette;* Quaranta 1847, 73: *un pezzo a foggia di tronco d'albero.*; Falkener 1852, 70: a marble trunk of a tree, which had served as support to some statue; Niccolini 1854, 21: *un tronco d'albero;* Minervini 1855, 86; Döhl 1976 I, 52; Dwyer 1982, 25:ii: base, in the form of a tree-trunk.

Description and comments: This trunk is more probably from a different statue than No. 27, as it was not linked to it in early reports; they were both discovered in the atrium, but not at the same time. The marble was not described by early scholars, but is probably white.

¹⁴⁹ Falkener 1855, 69–71: upper floors.

¹⁵⁰ The measurements vary according to different authors: ca. 78.4, 79.2 or 81.28. Three *palmi* would be ca. 79,30.

¹⁵¹ Döhl 1976 II, 143. – His suggestion that the tree trunk and the mask would be parts of this statue is not supported by any evidence.

¹⁵² Dwyer 1982, 126, note 4.

¹⁵³ Falkener 1852, 69–71: upper floors; Niccolini 1854, 21: *giardinetto superiore.*

Conclusions

The above catalogue consists of 28 pieces, which is more than the total researched by previous scholars. The larger number is a result of my accepting the identifications made by Dwyer, and including the forgotten and stolen pieces.

Materials and artists

Marcus Lucretius' statues were for the most part made of white Italian marble, certainly of Carrara, with veins of different colours but mostly greyish. It can still be considered pure white. Some statues were fashioned from different marbles. Two varieties were used for the two herms: (No. 2) white for the protomes, and white with greyish veins for the shaft, and (No. 4), white with violet veins for the protome, and white with darker veins for the shaft. Three varieties were used for the satyr (No. 7): the figure itself was made of crystalline white, the base of possibly *bardiglio*, and the pillar of greyish marble. Imported marble came from Paros for Silenus (No. 1), an unidentified greenish Greek marble for the cow (No. 15), and *rosso antico* for the head of Bacchus (No. 19). Marcus Lucretius' choice of materials follows the common picture derived from other Pompeian gardens.¹⁵⁴ According to the early reports the sculptures were painted with bright colours, although now only vague traces remain. An exception is the oscillum (No. 21), with some details still retaining their colours.

Information on Pompeian sculptors working in marble is limited. There certainly was a local production, and generally the workshops can be traced when the question is of serial production, such as peltae and herms. The peltae and the pinax have clearly several common features. The two statuary groups depicting cupids, dolphins, and octopuses are also by the same workshop.

Hermes

Four examples of herms, so popular in Pompeii, were also found in the garden of Marcus Lucretius. They were all double herms with young and old features, thus beardless and bearded, and with horns or with effeminate curls. The protomes were probably made by different craftsmen than the shafts. The height of Marcus Lucretius' remaining garden protomes varies from 18.5 to 21.0 cm. The red example is 16.0 cm high, and the smaller size may be due to the use of a more costly material. The shafts vary from 99.0 to 120.0 cm, leaving the faces visible across the low walls of the back side of the garden.

¹⁵⁴ Overbeck 1856, 219. On a general level, there were some statues of bronze, which led e.g. Johannes Overbeck to have false ideas about the material when describing the House of Marcus Lucretius, when he commented that the small animal statues around the *piscina* were made of bronze. Later edition Overbeck – Mau 1884, 318 had it corrected. Overbeck had written the first edition without research done in Italy, so the book was full of mistakes, Moormann 2015, 58. – Other rare materials in Pompeii were, according to the excavation reports: 'alabastro', 'gesso', 'pasta egizia', 'smalta vitrea'. Döhl 1976 I, i.

The identification of specific subjects for the herms in Marcus Lucretius' garden has been difficult; previous research, e.g. Panofka, identified the herm (No. 5) correctly as "due Bacchi", with young and old face, and the other ones incorrectly as Bacchus and Proserpina (No. 4), and Mercury and Vesta (Nos. 2 & 3). Fiorelli, for his part, wrote that the double herms' old face depicted a bearded Bacchus and young faces satyrs or bacchants.

The double herms in the front of the garden (Nos. 2 & 3) are very similar, with only minor differences, and were thus perhaps even made by the same sculptor.¹⁵⁵ These two herms had their bearded faces towards the viewer standing in the tablinum. The two herms next to the *aedicula* (Nos. 4 & 5) had their young beardless faces towards the main view towards the tablinum, while a viewer situated behind this vantage point (i.e. in the peristyle corridor 41 and the *oecus* 21) saw only the bearded faces. From the main point of view from the tablinum towards the *aedicula*, the old faces were surprisingly placed first, and the young ones behind them. The differently aged faces are most probably situated in this way in association with the main protagonist, Silenus, inside the *aedicula*. This follows the normal combination seen in wall paintings: Silenus is with the young beardless Bacchus.¹⁵⁶

Suspended Reliefs

The seven suspended reliefs, analysed here, correspond with the available locations for each object around the peristyle. Marcus Lucretius' oscilla represent all three of the characteristic types: round discs, rectangular pinakes, and lunate peltae shields. In addition to the oscilla proper, a hanging mask was also included in this category. Peltae were clearly the favoured oscillum type of Marcus Lucretius. The griffin-headed pelta was a novelty in the Roman world, and was also fashionable elsewhere in Pompeii in the first century AD. Most probably they were made locally and their main motifs were linked with Bacchus. As to the iconography of Marcus Lucretius' suspended reliefs, the Dionysiac offering scene is a rarity.¹⁵⁷ Other representations, such as the face of a satyr, a syrinx, and a dolphin belong to the Dionysiac sphere. The mask depicting Pan (No. 20) also belongs to the Dionysiac sphere. Its head is decorated with cluster of berries as is the head of Bacchus (No. 19). Marcus Lucretius' three pelta-shaped oscilla (Nos. 22, 23 and 24), and even the pinax (No. 26), are probably by the same artist, judging from the similar iconography. Not all of Marcus Lucretius' suspended reliefs were newly made. The holes in the pinax indicate that at some point it was only visible from one side and was perhaps reused.

Statues

As elsewhere in Pompeian gardens, the companions of Bacchus were the main protagonists. Silenus (No. 1) stood inside the *aedicula* in Marcus Lucretius' garden, dominating the whole scene. The exact location of the other acephalous Silenus (No. 27) is unknown. Silenus was not only depicted in sculptural form in this house, as he is also one of the most

¹⁵⁵ *Marmora pompeiana*, 269.

¹⁵⁶ More to follow in my doctoral thesis.

¹⁵⁷ Hundsatz 1987, 68–72.

important subjects of the wall paintings, together with the infant Bacchus, in the central panel of the south wall in room 16 (now MANN 9285). There were three satyrs, Nos. 7 and 8, one behind the other in the northern side of the garden, the Aposkopos and the hip-herm with a goat and a kid. The third (No. 6) satyr with Pan was in the forepart of the garden. These mythological figures must have drawn most of the viewers' attention due to their larger size and fine workmanship. Besides these two groups, there were two more groups consisting of a cupid, a dolphin and an octopus. (Nos. 8 and 10). Exceptionally, the cupids are depicted in considerable agony from the ferocious attacking octopus. Interestingly, these two groups were not situated nearby their natural element, the water in the basin. They were instead presented in the foreground near the tablinum, possibly due to their small size.



Fig. 55. Detail of the A side of the pinax I.I.26.

The other isolated statues, three hares, three birds, a cow, and a deer, were not rendered in the same scale. The cow is about the size of the rabbits, and the deer only a little larger. The birds (two ibises and one duck) are about their natural size, as are the hares. It is difficult to distinguish between the hares and the rabbits. They were neither considered wild nor tame. Pliny compared their relationship with men to that of dolphins; both were of an intermediate nature, like swallows and bees.¹⁵⁸ The long ears of the hares have not often survived, which is why it is often not easy to differentiate between hares and other animals, e.g. dogs, as in the case of the stolen hare (No. 11) known only from the pictures.

Two of the three birds were ibises, sacred in Egypt but unusual in Italy. Egyptian or eastern influences are not visible in Marcus Lucretius' sculpture except in these ibises, and ducks were rare in Nilotic scenes. In addition, a glazed statue discovered in the house depicts the god Bes.¹⁵⁹ Nilotic scenes and other Egyptian subjects were a common motif in Pompeii, visible e.g. in the garden of the house of Octavius Quartio (II 2,2), and even in a wall painting (Isis-Fortuna) in a house neighbouring Marcus Lucretius'.

Some small animal statues would originally have been placed very near to the basin, and could have functioned as water spouts. Examples include the hares' muzzles (Nos. 12

¹⁵⁸ Plin. nat. 8,220. *Hi mansuescunt raro, cum feri dici iure non possint; complura namque sunt nec placida nec fera, sed mediae inter utrumque naturae, ut in volucris hirundines, apes, in mari delphini.*

¹⁵⁹ Pietilä-Castrén p. 130.



Fig. 56. Giorgio Sommer's photograph (albumen print) ca. 1875. The original number is 1221.

and 13) and the cow's muzzle (No. 15).¹⁶⁰ The main water spout was Silenus' wine skin (No. 1), from which water ran over the steps and the platform leading to the basin.

Evaluation of the Collection

The mismatched statues have been a problem for realistically minded viewers. One could even hazard a comparison to modern garden gnomes.¹⁶¹ The quality and workmanship as visible in their current state varies from mediocre to high. They certainly must have looked better when fresh, painted and surrounded by greenery. They have suffered through weathering after their discovery, and from vandalism, either partially or over their entire surface. There were both art sellers and local sculptors in Pompeii. It is not possible to say which of these examples were of local production and which imported. However, it is clear that some pieces in the collection were reused, e.g. the satyr *aposkopos* (No. 7) and the hip-herm satyr (No. 8).

¹⁶⁰ In *Domus Pompeiana*, 69, Eeva-Maria Viitanen and James Andrews listed the cow, but only one of the hares, however both of them have drilled holes.

¹⁶¹ Farrar 2000, 104. She calls this feature 'rusticity'. Many motifs would not have been used inside the house, but only in the garden.

Marcus Lucretius' collection of sculptures is not unique by any means. The Sileni with wineskins are common – in fact here we have two copies. The Bacchic double herms are common as well, four out of about fourteen found in Pompeii. The herm with horns (No. 5) is especially important because it is a rare feature in sculpture, but it is a more common type in wall paintings. The groups depicting cupids with dolphins belong to a larger category of statues combining humans with dolphins. Hares and deer were also typical subjects of animal statues in Pompeii, and elsewhere in the Vesuvian area. All of the suspended reliefs also depict typical motifs. The rarest type in Marcus Lucretius' collection is the hip herm (No. 8), as well as the cow (No. 15), with even its material of Greek marble being exceptional. The garden of Marcus Lucretius was a mixture of the wild, the half-wild, and domestic elements.

The similarity and symmetrical position of many of the statues may indicate that some were purchased at the same; this could be the case for both the double herm pairs, both groups of cupids, octopuses and dolphins, and possibly the hares as well.

Marcus Lucretius' garden may have been small, but the owner wanted to make it visible from many perspectives – for his *familia*, for guests, and even for passers-by. It opened onto several rooms, through the tablinum to the atrium, and to both the *triclinia*. It was important to its viewers. The main axis was from the *ianuae* all the way to the *aedicula*. But it was also an intimate one, visible from the small study and the peristyle corridor.

In the garden of the House of Marcus Lucretius, Bacchus was depicted in various forms. Herms are the most common sculptural depiction of Bacchus in Pompeii, and the other statues were either his companions (Sileni, satyrs, cupids) or animals (most certainly dolphins) linked to him. I would like to criticize Döhl's idea that the large quantity of Bacchic material makes it nonreligious. Mythic elements were visible everywhere in the collection, and were certainly of importance to the owner. All of the 28 pieces of sculpture presented in the catalogue – including the Egyptianizing material so much favoured by the Ptolemies – depict the Bacchic entourage and its habitat, and thus the owners' Bacchic/Dionysiac interests. The eight animal statues can be linked either to wildlife, or to nature in general.

One, if not two of the three hares, were eating grapes, the iconic gift of this precise god. In addition, deer and dolphins were his own particular animals, the latter being painted also on the walls of the *aedicula* behind Silenus.

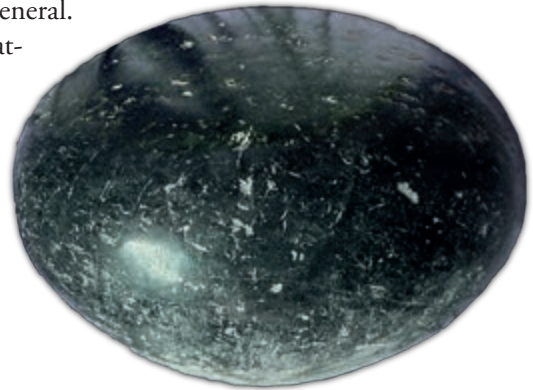

Fig. 57. The polished stone of dark green porphyry was later placed in the garden. Diam. 35 cm, P 59426.

Through their iconography, all of the statues, herms, and oscilla direct ones thoughts to the Bacchic world. The sculpted and painted images of the house did tell a tale. The garden is admittedly not a ritual cave, nor a large setting in the wilderness, but there was a clear theme to follow while looking around the home. The collection was a combination from different sources, some reused, out of their original context, and of various quality, but they formed a unity. At the very least, we could say that Marcus Lucretius combined meaningful aesthetic and religious elements in the spaces of his everyday life.



The picture taken by Wilhelm (Guglielmo) Plüschow shows that time was spent idling in the midst of the statues. The Italian boys were Edoardo and Vincenzo Galdi. Alma-Tadema's collection. (Cadbury Research Library, University of Birmingham.)

I.2 Minor Arts of Terracotta

LEENA PIETILÄ-CASTRÉN

Introduction

Sigilla arte fictili, sigillaria, strenae – these were the Latin words most often used for terracotta figurines in Roman times. Sometimes, the Greek terms *apophoreta* and *xenia* were also used. During the last days of the Saturnalia, little images of various kinds were given as popular New Year's presents, even earning themselves a special feast, the *Sigillaria*.¹ They were initially offered, according to Macrobius, as propitiatory votives to Saturn, on behalf of Dis, on behalf of the male head of the house as well as his family.² After the feast, the figurines sometimes found a place in the house, or even in tombs. In the city of Rome, we know that figurines were sold (albeit likely not exclusively) in a place also called the *Sigillaria*, along with books, crockery, and silver.³ An equivalent locale at Pompeii is not known, but a workshop in the southern area outside the city walls has been identified. It was active until the last days of Pompeii, and produced both bronze and terracotta figurines.⁴ It would be natural to think that, in general, the sale of figurines took place in the coroplasts' workshops, and perhaps seasonally by itinerant street traders as well.⁵

Ten items were analyzed for this chapter and in addition to the figurines, a glazed statuette, the only one of this type in the EPUH-material, No. 10, was also taken into consideration. The criteria for including in this research was small size (the largest dimension not exceeding 20 cm), material (fired clay), and the item's nature as a work of visual art. Among the earlier researchers on the figurines from the House of Marcus Lucretius, some confusion seems to have prevailed concerning the correct draped male and the gladiator.⁶ This is perhaps unsurprising, as figurines in general, and especially in this house with its splendid wall paintings and luxury items, often seem to possess little appeal to researchers, without much need to categorize them properly. Indeed, one of the first individuals to research the figurines, Hermann von Rohden, described their workmanship as often "sehr roh, roh und wertlos," and "künstlerisch ohne jeden Wert."⁷ These items originate from

¹ Macr. *Sat.* 1.10.24; Suet. *Claud.* 5.

² Macr. *Sat.* 1.11.49; Arnob. 6.11.2. Nilsson, *s.v.* Saturnalia, *RE* IIA1 (1921) 204.

³ Suet. *Nero* 28.2; Gell. 2.3.5; 5.4.1. D. Palombi, *s.v.* Sigillaria, *LTUR* 4 (1984) 310.

⁴ d'Ambrosio – Borriello 1990, 15. See also Frese 2016, 54, about a deposit of figurines with moulds, instruments, and colour pigments near the temple of Apollo, from the second century BC.

⁵ The set of five figurines, discovered in Pompeii at the intersection between the Via delle Suonatrici and the Via dell' Abbondanza, may have been part of a vendor's stock, *Pompeii AD 79*, figs. 36–40.

⁶ Vacillation can be seen, *e.g.*, in the exhibition catalogues *Pompeii AD 79*, figs. 299–302, *Sangue e arena*, 363–364, figs. 80–84, and *Domus Pompeiana*, 143, figs. 10.4–5. The references in the original diaries are not always explicit, but Hermann von Rohden was already as meticulous as possible in 1880, thirty-three years after the excavation, likewise Dwyer 1982, 23. In verifying the figurines in the current catalogue I owe thanks to Dr. Ria Berg for her persevering work.

⁷ von Rohden 1880, 49, 50, 56: "very crude, crude, and worthless" and "without any artistic value."

the first excavation in 1846–1847. Four more were discovered during that time, but could no longer be located during this course of research.⁸ Seven (Nos. 1, 4–9) were discovered in the service area of the House of Marcus Lucretius and three (Nos. 2, 3, 10) elsewhere in the house.

Catalogue

The catalogue is organized according to subject matter: female, male, groups, and grotesques. The description of each item covers the pose from feet to head (or bottom to top), beginning with an overview of the whole and then proceeding to the description of details. The words *right* and *left* in the descriptions refer to the item's own right and left, i.e. according to its own facing. Technical features such as moulding marks and traces of tooling are also taken into consideration. All dimensions are given in centimetres. The clay is described using the *Munsell Soil Color Charts*' equivalents, noting the quality, possible inclusions, and the tactile feel. As for the decoration, all traces of painted colour are noted, in an endeavour to reconstruct the original visual effects. Analyzing the iconography of the figurines, both individually and as a group, may further our understanding of the use and decoration of the domestic spaces and possibly even the items' initial function and distribution in the house.

Abbreviations used in the catalogue:

D = diameter

H = height

L = length

MANN = Museo Archeologico Nazionale di Napoli

p = preserved

San Giorgio inv. = Ms. inventory of the Naples Museum, compiled ca. 1840–1868.

Th. = thickness

W = width

Female (Nos. 1–5)

1.2.1 Standing Draped Female (Fig. 1, Cat. 195)

MANN 20638 (San Giorgio inv. 5262).

Place of discovery: Kitchen or nearby rooms (11–14; August 13th 1847).

Dimensions: H 14.3; W max at elbows 5.2; H base 1.5.

⁸ Dwyer 1982, 32:iii–iv, and 35xviii–xix. We were luckier than Dwyer, as we succeeded in locating his 35:xx = No. 5, and 36:xxiv = No. 9.

Technique: Front and back moulded. Open underneath. Tooling on right side from temple to elbow, on left side from shoulder to shoulder blade.

Clay: From light reddish brown (5 YR 6/4) to light brown (7.5 YR 6/4). Very hard, fine.

Decoration: Creamy yellow slip on palla, reddish brown on face, darker brown on tunic.

Condition: Intact. Blisters on shoulders. Traces of fine roots on lower parts.

Bibliography: PAH II, 469⁹; Falkener 1852, 82; von Rohden 1880, 70; Dwyer 1982, 35:xvii, pl. V, fig. 17; Pietilä-Castrén 2008, 140, fig. 10.2.

Description: She stands on a square base, rounded at the back and cast with the figure. Her weight rests on her right foot, with her left knee projecting and her feet almost assimilated into the base. The cloak is tightly swathed around her body and over her head, forming a diagonal fold from her right knee to her left hip, and concealing her right arm, which is lifted up to her breast, but leaving the hand uncovered; her left hand rests on her hip. At the back, the cloak falls in a narrow fold on the left side. The hair frames a round face with pointed chin; the eyeballs and flat nose are barely visible. Either long hair or a veil is visible on the upper back.

Comments: This is a late version of the heavily draped female figurine type, also called Sophoclean due to the similarity to representations of the philosopher enveloped in his himation. The Sophocles type, created in Athens around 330 BC, was adapted to the portrayal of females by the addition of a chiton, and was since produced with many local subtypes over a large area from mainland Greece to the Black Sea, from Cyprus to Sicily and Latium.¹⁰ This Pompeian Sophoclean is a sturdy representative of the type, giving a blurred impression, since all the outlines are indistinct, and was perhaps produced from a later generation mould, or a mould worn from use. In the Roman context she represents a married woman, with the appearance of her dress – she wears a *tunica* and *palla* – recalling the widespread type of *Pudicitia*, emphasizing modesty and piety.¹¹ More particularly, the figurine could be interpreted as the very popular comedic character of the shrew, which made frequent appearances in various literary situations. In the form of this parodic character, she is well known among the terracotta statuettes at Lipari in the early third century BC.¹²



Fig. 1.

⁹ PAH gives two robed females of 13.2 cm and respectively 15.8 cm of height. Only one was now discovered.

¹⁰ Tanagra, 199–201; Parisi 2016, 189–190.

¹¹ An example in marble is the statue of Viciria from Herculaneum, *Ercolano*, 160–161, 262, no. 49, and a more modest version in the portico of the Stabian Baths in Pompeii, with her right hand hidden by the folds, H. Eschebach, *Die Stabianer Thermen im Pompeji*, (Denkmäler antiker Architektur 13), Berlin 1979, p. 17, pl. 52, b.

¹² Tanagra, 133, fig. 79; Bernabò Brea 2001, 101–102, figs. 100–104; Bernabò Brea 2002, 59, fig. 33.

I.2.2 Standing Draped Female (Fig. 2, Cat. 221)

MANN 21612 (San Giorgio inv. 5268).

Place of discovery: Tablinum (15; March 31st 1847).

Dimensions: pH 7.8.

Technique: Front moulded, concave back; details added by tooling. The object on the left arm is of added clay.

Clay: Dark reddish gray (5 YR 4/2), with black inclusions. Hard. On back side pinkish gray (5 YR 6/2) lumps of plaster.

Decoration: Yellow (10 YR 8/6) slip all over. Traces of gilding on left side, tympanon, and hem.

Condition: Acephalous torso, preserved from shoulders to ankles. Several cracks.

Bibliography: PAH II, 461; Quaranta 1847, 72–73; Falkener 1852, 57–58; von Rohden 1880, 56–57, pl. 46,2; Levi 1926, 188, no. 824; Dwyer 1982, 37–38:iv, pl. VII, fig. 23; Pietilä-Castrén 2008, 142, 145, fig. 10.7.

Description: Her weight rests on her left foot, with right knee thrust out. She wears a tunic with highly accentuated drapery, and a palla, which covers the waist, wraps around the left shoulder, and hangs down in vertical folds. Her right elbow is bent, with her palm touching the circular shallow object resting on her left hip; underneath the object, the left fingers are modelled with a small lump of clay. The figurine is pierced at the left hip, apparently for affixing the figurine to its background with a nail. See No. 3 below.

Comments: The iconographic type of a female figurine wearing a mantle over a chiton is extremely varied, and dates back to the fourth century BC.¹³ An early parallel from the Athenian Kerameikos, considered to be either a worshipper of Cybele or an Aphrodite, depicts a draped female leaning on a low column with vertical fluting under the tympanon.¹⁴ The similarity in stance and overall iconography to our example is striking, despite our figurine's strong tooling, which adapts the flutes of the column to the drapery's vertical folds. A related pose is depicted in another female figurine striking a tambourine, from second or first century BC Egypt.¹⁵

The unspecified round object, balanced on the left arm or hip of a standing draped female, attracts numerous proposed interpretations, from a patera, a crown, or a fan, to a Muse's theatrical mask. In the earlier literature, the object on our figurine was considered to be either a tympanon or a small shield, thus



Fig. 2.

¹³ Merker 2000, 139–142; *Tanagra*, 276, fig. 214.

¹⁴ Vierneisel-Schlörb 1997, 48–49, no. 144, pl. 28.

¹⁵ Bailey 2008, 68, no. 3202, pl. 36.

depicting Athena/Minerva.¹⁶ The ample cloak and the position of the right arm and palm, admittedly difficult to discern on such a small scale figurine, seem to favour the idea of a tympanon, and thus an association with the rites of either Phrygian Cybele and Attis, or Bacchus,¹⁷ if she is not a generic musician in a musical group. For further comments, see No. 3 below.

I.2.3 Standing Draped Female (Fig. 3, Cat. 219)

MANN 21611 (San Giorgio inv. 5267).

Place of discovery: Tablinum (15; April 1st 1847).

Dimensions: pH 8.3.

Technique: Front moulded, concave back; details by tooling.

Clay: Dark reddish gray (5 YR 4/2), with black inclusions. Hard. Pinkish gray (5 YR 6/2) plaster on the back side, on the upper body.

Decoration: Yellow slip (10 YR 8/6) all over. Traces of gilding on neckline on both sides (=back and front), and hem.

Condition: Preserved from shoulders to mid-calf.

Bibliography: PAH II, 461; Quaranta 1847, 73; Falkener 1852, 57–58; von Rohden 1880, 56, tav. 46,1; Levi 1926, 188, no. 823; Dwyer 1982, 37:iii, pl. VII, fig. 22; Pietilä-Castrén 2008, 142, 145, fig. 10.7.

Description: Her weight rests on her right foot, with left knee forward and left arm at rest. She wears a peplos with short overfold (*apoptygma*), framed by vertical pleats, which forms a deep V-shaped fold at the neck and dips in zigzags diagonally to the hips. In large-scale statuary this severe drapery style often appeared with a fold (*kolpos*), but this detail was usually omitted by coroplasts.¹⁸

Comments: As an iconographic type, the peplophoros dates back to the fifth century BC, the garment being especially ideal for representing the robes of Athena or Persephone. Well-known peplophoroi of the early Imperial period are the famous Herculaneum bronzes, found in the garden of the Villa of the Papyri. They are considered to be dancers, hydrophoroi, or Danaids; two of them in particular (MANN 5620 and MANN 5604) seem to represent the same pose as our little figurine, which in the older literature was interpreted alternatively as Minerva or Ceres. As it is without any identifying attributes, the figurine could also be a generic votary.



Fig. 3.

¹⁶ In the bibliography above and in the *Inventario Generale* of the *Soprintendenza archeologica delle province di Napoli e Caserta* for the year 1979.

¹⁷ In the Villa di Cicerone in Pompeii there are eight dancing maenads in a wall painting, presented in vignettes, assuming various poses and with different attributes. One of them, robed in a tunic and a large cloak, is striking a tambourine, though with uplifted hands, but obviously in a Bacchic cult frenzy, *Rosso pompeiano* 162.

¹⁸ Merker 2000, 24–25.

Von Rohden pointed out the resemblance to woodwork of the vertical, strongly tooled drapery on both this peplophoros and the preceding tympanophoros (I.2.2).¹⁹ Falkener interpreted these figurines as ancestral portraits, but female figures as caryatids traditionally served as supports, taking the place of a column. They must have been rather parts of the decoration of the gilded stucco ceiling of the tablinum,²⁰ perhaps forming parts of slender columns in imitation of candelabra and emerging from the calices.²¹ Regardless their actual function, both of these figurines carried on, albeit on a small scale,²² a Greek iconographic tradition of considerable longevity.



Fig. 4.

I.2.4 Standing Naked Venus (Fig. 4, Cat. 194)

MANN 20316 (San Giorgio inv. 5264).

Place of discovery: Kitchen or nearby rooms (11–14; August 13th 1847).

Dimensions: H 16.5.

Technique: Front and back moulded, open underneath. Tooling on details and joins. Vertical brush strokes. Clay between legs and arms not removed before firing.

Clay: Yellowish-red (5 YR 5/6). Fine and hard.

Decoration: Reddish-brown (5 YR 5/4) and light reddish-brown (5 YR 6/4) slip all over.

Condition: Intact.

Bibliography: PAH II, 469, Falkener 1852, 82; von Rohden 1880, 50:2, pl. 38:2; Winter 1903, 213:2; Levi 1926, 189, no. 830; Dwyer 1982, 34:xvi, pl. V, fig. 16; Pietilä-Castrén 2008, 142, 144, fig. 10.6.

Description: She stands on a low circular base, which is cast with the figure. Her weight rests on her right foot, with her right hip out thrust and left knee projecting forward. The toes are clearly distinguished. The body's details are indicated. She wrings out her hair, parted in the middle, with both hands, elbows out and fingers towards front. The face is round, with a rectilinear mouth and small indistinct nose; both eyelids are pronounced, with the left eye larger than the right. She is accompanied by a short ithyphallic herm whose tapering shaft stands on a square

¹⁹ von Rohden 1880, 56.

²⁰ According to PAH II 461, "alcuni frammenti di cornicette dorate" were discovered in the same connection. – On the use of gilding in architecture, both for protection and for decoration, Mulliez 2014, 128.

²¹ They may have taken their inspiration from earlier wall paintings, analogous to the female figures of the late Second Style on the walls of the Villa della Farnesina in Rome with their surprisingly varied drapery, see E. La Rocca, *La pittura di un impero*, I.11–12, p. 166–169, 173–174, 273. Perhaps comparable also to a late Augustan pair of peplophoroi in stucco standing on pedestals from a tomb outside Rome, see H. Mielsch, *Römische Stuckreliefs*, (RM 21), 1975, 27, 226, K14, pl. 9, or to the warrior figures in high stucco relief, standing on consoles in tepidarium E in the more closely contemporary Suburban Baths in Herculaneum, Ling 1991, 97. Guidobaldi 2008, 68. In room 42 of Nero's Domus Aurea is a combination of polychrome painting and figurines modelled of stucco: see, e.g., I. Iacopi, *Domus Aurea*, Rome 1999, 109, 125, fig. 118. Cf. also

²² Bartman 1992, 41.

plinth. He leans tightly against her legs, reaching up to her hip. His head is that of a child, a little Cupid with a rounded face, small smiling mouth, snub nose, and round eyeballs. The hair is parted in the middle.

Comments: She is the goddess Venus, the tutelary deity of Pompeii, born from the sea. She is not represented as the Greek full-fledged Anadyomene, but a maturing girl in her teens. The type originated in the fourth century BC. and became widespread from the second century onwards, with continual variations.²³ It imitated the pose of the Polycleitan Diadoumenos, its weight resting on the right foot and the upper body turned slightly to the right with arms lifted,²⁴ and continued to be produced in terracotta as late as the end of the fourth century AD.²⁵ Our miniature figurine may once have decorated the domestic shrine (lararium) of Marcus Lucretius' house.²⁶

A mould sibling comes from the *bottega* VII, 16, 18, dated to the first century BC or later.²⁷ The same iconographic type also appears in other materials at Pompeii, for example a bronze statuette discovered in a cubiculum of the Casa di Trebius Valens (III, 2, 1) along the Via dell'Abbondanza,²⁸ and a small, half-draped marble statue found in the portico of the temple of Isis as a votive offering.²⁹

I.2.5 Bust (Figs. 5a–b, Cat. 200) MANN 21198 (San Giorgio inv. 5247).

Place of discovery: Kitchen or nearby rooms (11–14; August 13th 1847).

Dimensions: H 13.5; D base 5.0.

Technique: Front, back of head, and shoulders moulded; torso inserted into circular base; tooling on the joins, sides, under the shoulders, and the strands of hair.

Clay: Reddish-yellow (7.5 YR 6/6). Fine.

Decoration: Reddish-yellow (7.5 YR 6/8) slip on hair. Pink (10 R 8/3) on tunic. Dark brown (7.5 YR 3/2) eyes, eyelashes and brows. White slip under chin and upper right part of face.

Condition: Intact.



Fig. 5a–b.

²³ Berg 2017, 213–214: “una vera e propria icona culturale della bellezza alla greca”.

²⁴ N. R. Bloch – N. Minot, *s.v.* Aphrodite, *LIMC* 2 (1984) 54–55.

²⁵ Grandjouan 1961, 7.

²⁶ Bartman 1992, 45; Bowes 2015, 2011. – About the role of Venus, Van Andringa 2009, 266–267.

²⁷ MANN 13555; d’Ambrosio – Borriello 1990, 30, pl. 8, fig. 28: Venere con ermetta priapica.

²⁸ SAP 2275, in *Storie da un'eruzione*, 132–133, standing with her weight on her left foot.

²⁹ MANN 6298, a naked marble statuette, has the weight on her left foot and the same pose: D’Acunto 2008, 176, no. D19. The Pompeian Anadyomene copies are listed in Carrella 2008, 93.

Bibliography: PAH II, 469–470; Quaranta 1847, 160; von Rohden 1880, 70:7, Dwyer 1982, 35:xx (unable to locate item).

Description: The bust rises from a round, low foot, set off by a groove, and consists of a fully modelled head, and chest modelled naturalistically in front and cut diagonally at the back. The tunic, which appears lightweight, is draped symmetrically, forming a low V above the bosom. She has a long neck with Venus rings and a nascent double chin. The face is round, with a small mouth, full lips, and straight nose. Her brown eyes, with dark lashes and brows, look to the right and upwards. The coiffure is rendered with two rows of small snail-shell curls that frame the face, the forehead, and the temples, leaving the earlobes visible; undulating lines of single strands of hair fall below the ears. The hair on top of the head is drawn back in narrow waves and bound with ribbon to a plait at the nape of the neck.

Comments: This miniature portrait probably represents the lady of the house, already of mature years. It may have been originally displayed either in the lararium as part of the domestic cult, or elsewhere in a prominent location, perhaps the triclinium.³⁰ According to the earlier reports, it was originally gilded, thus creating an illusion of being fashioned from precious material. Representing a lightweight tunic as the only drapery was customary between the late first century BC. and the late first century AD.³¹ In female portraits, personal identity and physiognomy were usually suppressed and replaced by idealized beauty, in common with contemporary imperial portraiture.³² In this case, the physiognomy can be identified with Iulia Agrippina Minor, a prominent female member of the Julio-Claudian dynasty, and especially with the Stuttgart type depiction of the Empress's later years, around 54–55.³³ Our terracotta bust has two rows of small snail-shell curls, a reduced number compared to the marble bust's three rows, understandable due to its small size and the material used.

Male (Nos. 6–7)

I.2.6 Standing Draped Male (Figs. 6a–b, Cat. 198)

MANN 20258 (San Giorgio inv. 5271).

Place of discovery: Kitchen or nearby rooms (11–14).

Dimensions: H 16.0.

Technique: Front and back moulded; open underneath. Joins visible on left side.

Clay: Reddish-yellow (7.5 YR 7/6). Fine.

Decoration: Pinkish-gray (7.5YR 7/2) slip on neck, arms, and legs. Face, darker food item, and strap of the basket yellowish-red (5YR 4/6). Hair dark reddish-brown (5 YR 3/2), basket reddish-yellow (5 YR 6/6), the light breads in the basket reddish-yellow (7.5 YR 7/6). Off-white slip on tunic.

³⁰ Fejfer 2008, 91, 173. – In the House of M. Gavio Rufo also an unidentified feminine bust, though made of bronze, belonged to the domestic pantheon, Van Andringa 2009, 259.

³¹ Fejfer 2008, 255.

³² Fejfer 2008, 331, 355. Small terracotta busts of women resembling other wives of emperors were still made a hundred years later as is shown by the busts of the younger Faustina and Crispina in the British Museum, inv. nos. GR 1868.8–10.16, Terra Cotta C 692, and GR 1912.4–16.3.

³³ Trillmich 2007, 52–54, figs. 9–10.

Condition: Intact, except for the broken fingertips of the right hand.

Bibliography: Falkener 1852, 82 †; von Rohden 1880, 49, pl. 37:2, calls this figure a bread or fruit seller; Dwyer 1982, pl. VI, fig. 18, presents a photo of this figurine, but omits it from both his text and the running item numeration. He suspects some confusion, 35 n. 1, and instead describes another draped male, 35:xxi, as coming from the House of Marcus Lucretius; this figurine, MANN 20253, originates however from La Tomba del Vaso di Vetro Blu, for which see Valentin Kockel, *Grabbauten vor dem herkulaner Tor in Pompeji*, 152, no. 7, Mainz am Rhein 1983.

Description: He stands barefoot on a low circular base, cast with the figure. His weight rests on his right foot, and the toes are differentiated with parallel lines. He wears a white, knee-length tunic with a round neck and short sleeves. On the right shoulder is a cloth-like item with a fringe, hanging down to the chest in front and below the shoulder blades in the back. His outstretched right hand, which is disproportionately large, probably displayed an example of whatever he was selling. His head is turned slightly to the right; the face is round with a small mouth, small nose, and oval eyes with clearly marked eyebrows. The hair is cropped, leaving the ears visible. The basket, held in the crook of his left arm, has a strap that passes over his right shoulder.

Comments: The plaited basket with its clearly defined rim, possibly a *sportula*,³⁴ contains a dark brown item and two yellowish items which, following von Rohden, can indeed be interpreted as bread. The colour would depend on the ingredients – darker bread, perhaps *panis rusticus*, is depicted as shorter, with diagonal slashes across the top, and the lighter baguettes made with more wheat flour were perhaps *panis secundarius*.³⁵ The cloth on the figurine's right shoulder could thus be explained as a *mappa* to cover the basket and keep the bread warm. A mould sibling (Figs. 6c–d) comes from a Pompeian bakery (VI,



Fig. 6a–b.

³⁴ White 1975, 68–70. Cullin-Mingaud 2010, 201–202.

³⁵ Blümner 1912, 77–78. Palmeri 2007, 3. Borgongino – Stefani 2015, 104.



Fig. 6c–d.

3, 3),³⁶ supporting the identification of these two figurines as sellers of bread.

This figurine belongs to genre art. A comparison with the famous Pompeian wall painting from La Casa del Panettiere (VII, 3, 30) may help illuminate it. In the painting, a young beardless man wearing a white toga and large mantle distributes bread with his right hand. The majority of the bread displayed on the stall is white, but on the right-hand side is a basket holding darker coloured items. The scene is interpreted as a

distribution of free bread conducted during certain festivities,³⁷ or else as part of the activities of a *candidatus* campaigning for office.³⁸ Our figurine in his knee-length unbelted tunic might be performing these activities as a client for his patron.³⁹

1.2.7 Gladiator (Fig. 7a–b, Cat. 197)

MANN 20257 (San Giorgio inv. 5270).

Place of discovery: Kitchen or nearby rooms (11–14; August 13th 1847).

Dimensions: H 15.9.

Technique: Front and back moulded; open underneath. Tooling on right arm, right leg, and across middle of face. Clay between legs not removed before firing. Visible joins. Stud of added clay on left side of helmet.

Clay: Pink (5 YR 8/4). *Fine.*

Decoration: Dark red (10 R 3/6) slip on feet, right leg, and face, reddish-yellow (7.5 YR 7/8) between legs, and very pale brown (10 YR 8/2) on shield, greave, arm guard, loincloth, and shield.

Condition: Arm guard broken at biceps. Stud missing on right side of helmet.

Bibliography: PAH II, 469; Falkener 1852, 82. von Rohden 1880, 49, 52, pl. 41:1, presents a smaller (H 13 cm) but otherwise similar figurine. The difference is too great to allow for the same mould having been used. The same gladiator was thus created in the workshop in different sizes;

³⁶ TC 343 in the Antikensammlung in Berlin. It was discovered in 1809, as already noted by von Rohden 1880, 49. Also Winter 1903, 453, no. 2b.

³⁷ *La pittura di un impero*, 231, fig. IV,3, 296.

³⁸ De Caro 2001, 104–105, no. 107. *Life and death*, 28–29.

³⁹ In the frieze of the Tomb of Eurysaces, the baker, at Porta Maggiore in Rome, there is a three-man group on the far left side of the south frieze, the scene showing flour being sieved. Unlike most of the other *tunicati* of the frieze, the one in the middle is unbelted. He gives the *togatus* on the right, believed to be Eurysaces himself, something, a sample of the flour, or a receipt, thus being in a position of trust. Ciancio Rossetto 1973, 56; Zimmer 1982, 108; Wilson 2008, 408.

Winter 1903, 387:2; Levi 1926, no. 851, talks about several gladiators, and probably confuses MANN 20267 with our MANN 20257; Dwyer 1982, 36:xxiii, pl. VI, fig. 21, saw some gilding; Pietilä-Castrén 2008, 142–143, fig. 10.4.

Description: He stands on an oval base, cast with the figure, in the act of attacking an adversary. He is barefoot, with his weight on his left foot. The toes and kneecap are clearly modelled, the muscles of the right calf are differentiated with incised lines, and the left leg is protected by a greave (*ocrea*). He wears a loincloth (*subligaculum*) which ends in front in an oblong fold and covers the buttocks in schematic semi-circular folds held together with a belt (*balteus*). The spine and shoulder blades are indicated. The left side of the torso is hidden under a rectangular, slightly curved large shield (*scutum*), whose central vertical ridge (*spina*) is naturally reinforced by the joins of the two connected halves of the figurine. His right arm is protected by a padded guard (*manica*). He is armed with a short sword (*gladius*), and the head is protected by a helmet (*galea*) with crest, brim, and possibly a visor. The right eye, or eyelet, is indicated as a ring, the left one as a hollow.

Comments: His costume and armour are those of a Samnite (*Samnes*), the most heavily armed type of gladiator, or *hoplomachus* as they were later called, after the reign of Augustus.⁴⁰ From the Augustan era on, the helmet developed rapidly; around 10–20 AD it covered the face, leaving two openings for the eyes. Samnite armour was still in use in the Neronian age.⁴¹



Fig. 7a–b.

⁴⁰ Jacobelli 2003, 7.

⁴¹ P. Sabbatini Tumolesi, *s.v.* gladiatore, *EAA*, suppl. 2:2 (1994) 791.

Groups (nos. 8–9)

I.2.8 Sedan Chair Porters (Figs. 8a–b, Cat. 199)

MANN 20255 (San Giorgio inv. 5265).

Place of discovery: Kitchen or nearby rooms (11–14; August 13th 1847).

Dimension: H 12.7; W 15.8.

Technique: Front and back moulded. Tooling on head, face, ears, and at joins.

Clay: Pink (5 YR 8/3). Fine.

Decoration: Very pale brown slip (10 YR 7/3) all over, reddish-brown slip (2.5 YR 5/4) on the heads, legs, and arms of the porters, the neck, and lower part of the face of the seated person. Reddish-yellow slip (7.5 YR 7/8) between legs. Brown slip (7.5 YR 4/2) on the leather straps.

Condition: Fragments of the first porter's hand, calves, and base missing. Vertical crack on the base in the middle, and a horizontal crack above the base across the whole figure. A few blisters on the back. Encrusted in places, with traces of roots.

Bibliography: PAH II, 469; Falkener 1852, 82; von Rohden 1880, 23, 50, 70, no. 6, pl. 38,1; Winter 1903, 453:1; Levi 1926, 199, no. 857; Dwyer 1982, 36:xxii, pl. VI, fig. 20; Pietilä-Castrén 2008, 141, fig. 10.3.

Description: This figurine depicts a sedan chair (*sella gestatoria*) and its porters (*sellarii*), who stand on a tapering oval base cast with the figures. The men advance barefoot towards the right, knees bent under their burden; the rear porter is stooped. Both wear short chitons and padded cloths that are draped over their collarbones and form small oblong cloaks at the back. The leather straps are attached vertically between each porter and the poles; the straps go crosswise over their backs, forming a knot between their shoulder blades. Both men have their heads turned in three-quarters profile. The shape of the heads and the facial features seem to indicate an African origin; the faces are round, with prominent ears and cropped hair. The facial features are more clearly indicated on the rear porter; his mouth is straight with thick lips, the nose large and flat, and the forehead high. Only the right eye is distinguished by the curving line of the upper lid.

The *sella gestatoria* is a rectangular construction with feet at the corners, carrying poles, and a ridged roof. The curtain is drawn up from the inside on top of the roof, to reveal a rectangular opening on the right side. A female figure, portrayed as a bust, sits inside, resting her right arm on the sill. Her head is turned toward the right. The face is round, its features only vaguely indicated. The hair is drawn back and adorned with a diadem, indicated by an incised line.



Fig. 8.

Comments: The parallel to our *sellarii* in terracotta, of unknown though possibly Campanian origin, is now in Karlsruhe.⁴² It is dated to the second century BC on the basis of the porters' hairstyle, a plait on top of the head. While the basic composition is the same, its execution is of inferior quality. The porters, standing upright, seem to be wearing chitons and hip-length cloaks. The *sella gestatoria*, its roof low and vaulted, is open on both sides; its female occupant sits frontally, with her hair parted in the middle and her shoulders covered with a symmetrically draped cloak.⁴³ The basic subject is the same, but the workmanship and representation differ considerably.

The *sella gestatoria*, whose occupant was seated instead of lying in a recumbent position as in a *lectica*, was used by both men and women, in both town and country.⁴⁴ Porters were usually low-ranking members of the household,⁴⁵ but in this composition they are elevated in size to the status of protagonists, while the lady of the house is reduced to a diminutive size. This would perhaps indicate an apt gift for the Saturnalia, a feast where the normal roles in the household were reversed.

Our miniature figurine may once have decorated a domestic shrine of Marcus Lucretius' house, analogously with the famous terracotta group depicting Aeneas carrying ailing Anchises and holding young Ascanius by hand.⁴⁶

I.2.9 Twin Bacchic Heads (Fig. 9, Cat. 209)

MANN 24109 (San Giorgio inv. 5276).

Place of discovery: Kitchen or nearby rooms (11–14; August 13th 1847).

Dimensions: pH 6.2; pW 7.2; Th. 3.2.

Technique: Front and back moulded. Tooling on tops of heads and joins.

Clay: Yellowish-red (5YR 5/6). Hard.

Decoration: Red (2.5YR 4/6) slip in places on right head.

Condition: Broken below necks, extending lower in the back than in the front.

Bibliography: PAH II, 470; Falkener 1852, 82; von Rohden 1880, 70, no. 8; Dwyer 1982, 36:xxiv (unable to locate item).

Description: The two heads are depicted side-by-side. Both are decorated with fillets across the forehead that are fastened with corymbes at each side. The right-hand figure, depicted frontally, has a round face with bulbous eyes, an ill-defined nose (a common result when removing a figurine from the mould), and a small crooked mouth. The left-hand figure, with long curly hair, is rendered in three-quarters profile, turned slightly towards the centre; the facial features of both are identical.



Fig. 9.

⁴² Schürmann 1989, 257–258, no. 980, pl. 162.

⁴³ A chair, carried similarly on two poles by two porters, is part of a procession in a painting in La Casa delle Nozze di Ercole (VII, 9, 47), on the right side of the frieze. For an interpretation and possible connection to the banquet of the *sellisternium*, often held in a theatre, see Brian Madigan, *The Ceremonial Sculptures of the Roman Gods*, Leiden – Boston 2013, 98–99.

⁴⁴ E.g., Tac. *Ann.* 14.4; Suet. *Nero* 26.2; Suet. *Vit.* 16.1. W. Ramsay, s.v. *sella* III, *Greek and Roman Antiquities*, 1016. Daremberg – Saglio 1918 (3:2), s.v. *lectica*, 1005–1006, fig. 4378; Daremberg – Saglio 1918 (4:2), s.v. *sella*, 1179.

⁴⁵ Pesando 2012, 88, 191, fig. 42.

⁴⁶ Discovered in the lararium of the Casa di M. Gavio Rufo VII, 2, 16, for which e.g. M. Borriello, “Alle origini del mito”, 227, no. 127, *Giulio Cesare. L'uomo, le imprese, il mito*. Milan 2008.

The small pine cone of the thyrsus staff stands upright between the heads. The back is not modelled. *Comments:* A complete pair in terracotta with the same composition from late Hellenistic Capua has been interpreted as Bacchus and Ariadne.⁴⁷ Full-length examples of the couple, represented both standing and seated, were popular among the eastern coroplasts, especially in the first century BC.⁴⁸ A medallion from Herculaneum offers a parallel in a wall painting, in which the couple is interpreted as Bacchus and a maenad; the same poses are portrayed, but the thyrsus is on the maenad's far left.⁴⁹

Grotesques (No. 10)

I.2.10 Bes (Fig. 10, Cat. 139)

MANN 22589 (San Giorgio inv. 5259).

Place of discovery: Right-hand side ala (8; April 14th 1847).

Dimensions: pH 13.2; W 9.0; Th. 0.3–1.4.

Technique: Back and front made with the same mould.

Clay: Pink (2.5YR 8/4). Very hard, porous.

Decoration: Covered inside and out with turquoise blue glaze with a silvery tinge.

Condition: The better-preserved side is broken under the tongue. The tip of the nose, eyebrows, top of the forehead, right ear, and corners of the headgear are chipped. On the more poorly preserved face, only the right eye and forehead survive.

Bibliography: PAH II, 461–462; Quaranta 1847, 73; Falkener 1852, 55; von Rohden 1880, 61; Levi 1926, 31, I, pls. IV, fig. 13 and V, fig. 14; Dwyer 1982, 31:i; Di Gioia 2006, 119, no. 5.6; Pietilä-Castrén 2008, 138, 142, 145, fig. 10.1.

Description: The bifrontal head of this glazed statuette has its tongue lolling out, framed by a moustache, upper teeth, and a long beard. The snub nose is broad, the wide round eyes are surrounded by puffy lids, and the eyebrows form an open V on the strongly arched forehead. The double ears are prominent. The headdress consists of a tapering support decorated with upright petal-like ribbing on its lower section. The upper part is flat, with a quasi-rectangular opening on top, thus indicating the statuette's function as a fountain spout; the spray of water must once have simulated Bes's crown of feathers. Because of the glazing, it was watertight and especially appropriate for fountains and gardens.⁵⁰



Fig. 10.

⁴⁷ Besques 1986, 19, D3420, pl. 15.

⁴⁸ Mollard-Besques 1963, 78–79, pls. 94–95.

⁴⁹ *Romana pictura*, 235, 313, fig. 143.

⁵⁰ Di Gioia 2006, s. 15, 115, 139. *Cleopatra*, 203, 291, no. 130. In *La Casa delle Nozze d'Argento* (V, 2, i), a frog and a crocodile, both of glazed faience, were used as fountain spouts: *Life and death*, 154–156. Falkener 1852, 43, suggested a

Comments: Bes, the grotesque dwarf god and beneficent household deity, was very popular with all classes of society. He had apotropaic powers and protective functions, especially for women giving birth and people who were sleeping. Luxury items such as faience statuettes depicting Bes became fashionable from the Augustan era on, either through the direct influence of a local Egyptian colony, as at Pompeii, or from trade relations overseas. Our Bes, along with the other glazed objects, is considered to be an Egyptian import, possibly from Alexandria.⁵¹

Concluding Remarks

Our ten items come from the House of Marcus Lucretius, which was being renovated in 79 AD.⁵² Seven figurines (Nos. 1, 4–9) were salvaged from rooms 11–14 on the northern side of the house, earlier referred to as a “kitchen and related rooms”.⁵³ The EPUH Project managed to define their use more accurately: Room 11 was the corridor linking the service area to the atrium. Room 12 was probably used both as a light well and for storage, as deduced from the shelves on its eastern side. Room 13 was a toilet, and room 14 a kitchen, which in addition to specific constructions contained an unidentified element, possibly a cupboard.⁵⁴ Thus, there were two places available for the figurines: either storing them temporarily in the room 12, or for more established safekeeping in the room 14 perhaps as a kitchen lararium.⁵⁵

Two figurines (Nos. 2–3) were recovered in the tablinum, with its ceiling of gilded stucco. This was the space appropriate for receiving guests, even if the household’s prosperity was demonstrated unabashedly all around the house. Judging from the two figurines’ different technique and gilded surface treatment, they must originally have belonged to the tablinum, where they remained until the moment of their discovery. The fragmentary Bes (No. 10), for its part, was found in the southern ala (8), used for reception and as a waiting room for the adjoining triclinium. Its waterproof material shows that it was designed for outdoor use, perhaps as part of the fountain in the nearby garden.

As to the workshops and individual hands involved in their production, both the clay and the techniques employed may tell us something. The colours of our figurines are poorly preserved. The general presumption that locally made figurines were first coated with whitish or pale brown slip is supported by the traces on Nos. 1, 5, and 7–8. The clay used by the Pompeian coroplasts provides little help in drawing conclusions about indi-

marble statue for this function.

⁵¹ Di Gioia 2006, 140; Bailey 2008, 17–18.

⁵² Depending on the use of the rooms and the extent of the rebuilding activity in progress in AD 79. Dwyer 1982, 21, on the rebuilding after the earthquake in 62 AD, and on the changes made in the tablinum, 22, n. 3. Dwyer 1991, 35, says further that the House of Marcus Lucretius “was proudly inhabited at the moment of Pompeii’s destruction”. See also Viitanen – Andrews 2008, 61–62. About the portable material associated with religious activities, Allison 2004, 144–145.

⁵³ Dwyer 1982, 20.

⁵⁴ Viitanen – Andrews 2008, 63. On the use of internal corridors, Allison 2004, 82.

⁵⁵ There are numerous houses with more than one domestic shrine, Van Andringa 2009, 261.

vidual workshops, as it is believed to come from a single source not far from Pompeii.⁵⁶ The quantity of material is also too limited to identify any mannerist features, which might mark the product of individual hands. Hazarding a guess based on the overall impression of the figurines, however, Nos. 2–3 may have come from one workshop, Nos. 4 and 6 from another, and Nos. 7–8 from a third. The items are consistently from the first century AD.

Distinguishing between purely religious and decorative elements in a Pompeian display of the first century AD is not easy. From the religious point of view the Venus Anadyomene (No. 4) and the twin Bacchic heads (No. 9) are noteworthy, but figurines and statuettes had overlapping roles and micro-histories of their own, manifesting the personal taste and the interests of the owners.⁵⁷ In attempting to understand them, iconographic analysis is our greatest help, offering insight into both domestic life and life out-of-doors, including private and public religion and various purposes ranging from advertisement to entertainment. Among the items from the House of Marcus Lucretius there are subjects of Greek origin, which enjoyed considerable longevity, as well as characteristically Roman elements. In the female group we have the Peplophoros (No. 3), the oldest type, originating in Greece as a votive gift in the fifth century BC and still fashionable in the Augustan age, while the heavily draped ladies (Nos. 1, 2) and the naked beauty (No. 4) go back to late Classical and early Hellenistic models. The three explicitly Roman themes are the Gladiator (No. 6), proof of the popularity of gladiatorial spectacles, the female bust (No. 5) as an example of portraiture, and the genre figurines. Episodes from everyday life are portrayed by the porters with the sedan chair (No. 8), probably representing an outing of the lady of the house accompanied by her two slaves, but at the same time alluding also to the Saturnalia. The bread seller (No. 6) was also performing an ordinary task, but may have alluded to the insula's two bakeries as an important figure for the whole enterprise, but he may also have been advertising a free distribution of bread on a festive day. Bes (No. 10), an isolated example of Egyptian iconography, had religious significance as a protector of the household in addition to its practical role. The twin Bacchic heads (No. 9) belonged to the Bacchic world and the theatre. Our heavily robed female (No. 1) may also have alluded to the theatre as a Roman matrona, or else it was another reference to the matron of the house, as was the person sitting in the sedan chair depicted as a miniature portrait (No. 8).

When the principal lararium of the House of Marcus Lucretius was discovered by the western wall of the atrium in the 1840s, it was devoid of statues.⁵⁸ Taking into consideration the house's ongoing renovation, the most valuable items, perhaps of bronze,⁵⁹ may have been removed elsewhere and are currently lost. Whether some of the now remaining figurines of terracotta made originally part of its contents and were perhaps incorporated with those in the servants' premises, remains a possibility but impossible to verify.

⁵⁶ d'Ambrosio – Borriello 1990, 14.

⁵⁷ Kaufmann-Heinimann 1998, 182; Van Andringa 2009, 256.

⁵⁸ Falkener 1852, 51–52; Dwyer 1982 24, n. 2. The lararium was of the type of miniature temple on a high base, Bassani 2008, 25–26. The description of the lararium by Boyce 1937, 83, no. 408, with the wrong attribution, though, of five bronze statuettes belonging to this shrine. For which Giacobello 2008, 249, A38, IX 3,5,24.

⁵⁹ For the various materials used for the statuettes and figurines and the compositions of the lararia, Kaufmann-Heinimann 1998, 185.

II VESSELS

RIA BERG

Vessels comprise a significant part of the finds from the house: 137 catalogue entries (27.24 %).¹ The exact function of vessels is often unknown; they were often multifunctional, possibly adapted to improvised uses. Therefore, an artificial division according to the materials of the vessels is more practical than a functional classification, and it is also revealing about the relative value and status of the vases, and the catalogue of extant objects, below, follows this division. The materials of the vessel (or their parts) were: terracotta 48, bronze 46, glass 40, marble 2 and bone 1.

In Pompeian houses, comparisons between the relative quantities of vessels of different materials have been attempted by various scholars. As noted in previous chapters, terracotta vessels are quite obviously underrepresented in the early excavations. The specimens collected in the 19th century were either intact, contained some organic material (grain, olives), were stamped, or had an inscription. This is illustrated by the unfavourable comparison of the 48 terracotta vessels recovered from the House of Marcus Lucretius with the House of Julius Polybius, excavated in the 1970s, which contained 206 whole vases.²

The quantity of glassware from the House of Marcus Lucretius (40), in contrast, should be a somewhat more realistic total, even though it is clear that smaller fragments were not collected if they did not instantly appear to form a complete vase. There are also differences between the preservation of different vessel types. For example, unguent vessels tend to remain whole more often than larger, open forms, and therefore their recovered quantity should be considered reliably close to the original. Notably, in the House of Julius Polybius only 32 glass vessels were found (131 also counting sherds).³

Ernesto De Carolis (2004) has calculated percentages for vessels in various materials (glass, bronze, pottery, silver) for a number of Pompeian houses of different types.⁴ Glass wares amounted to an average of 41.3% in all types of houses. Large atrium houses with complete peristyle had 37.1% of glass vessels, atrium houses with an incomplete peristyle 34.4%, small houses with atrium and small garden 45.5% and tabernae 46%. De Carolis recognized a general trend of smaller houses having a slightly higher percentage of glass ware, whereas the more precious metal wares comprised a higher percentage in larger houses. The House of Marcus Lucretius glass percentage, 34.8%, is close to the peristyle house

¹ Minervini 1852, 20; Minervini 1855, 82: "E' inutile fare una particolare enumerazione di tutti i vasi rinvenuti nella casa di M. Lucrezio. Solo diremo brevemente che sono essi di forme e di usi differentissimi. Vedi varie conche, patere, olle, *coli*, unguentarii, caldaie (*ahena*), ed altri vasi di svariate dimensioni."

² Castiglione Morelli 1996, 105–108, fig. 5.

³ Castiglione Morelli 1996, 108, fig. 5.

⁴ De Carolis 2004, 75–77, tav. A-E.

average, thus indicating considerable wealth. The total amount of 40 glass vases equals Casa del Menandro with its 40, and is closely paralleled by Casa della Statuetta Indiana with 39, Casa del Fabbro, with 41, and Casa di Helvius Severus with 43 items.⁵ Lucia Scatozza Höricht has statistically analysed the relative quantities of glass and bronze vessels in the Houses of Regio I. She likewise observed that modest tabernae and officinae present very higher quantities of glass vessels, confirming their relatively low cost and status.⁶

The relation between domestic space and bronze vessels is particularly interesting, as bronze vases are, for several reasons, ideal indicators of a household's status. Bronze was an expensive material, and therefore indicative of the general wealth of a household, but not to the point that it would have been likely salvaged during or after the eruption. It retains its form and identifiability better than friable glass and corrodible iron. It was also considered an item of value by the 19th century excavators, who kept all bronze items, even loose rings and fragments of locks, and carefully marked them in inventories. Their morphology is also relatively standardized, and thus the types are well recognizable even from small fragments or inventorial descriptions.

Comparing the total numbers of bronze vases in a group of 14 wealthy Pompeian domus, the House of the Menander ranks as the richest with 52 vessels (Table 1).

The average amount of the above cases is 18 vases, but this is somewhat lowered by the Casa delle Nozze d'Argento, which was probably partially in a state of abandonment, containing only three bronze vessels, a number that could not have maintained the house on a



Table 1. Quantities of bronze vases in 14 Pompeian domus (according to Tassinari 1993).

⁵ De Carolis 2004, 75–76.

⁶ Scatozza 2012, 30, 39–43, tav. E2–G2; see also Castiglione Morelli del Franco, Vitale 1989, 212, tav. A, for percentages of glass in insula I, 8; Proto 2006, 22–27, for glass vessels in tabernae.

functional basis. The House of Marcus Lucretius, with its 46 items (39 whole vases), thus has a very a notable amount. Counting the average number of bronze vessels per house in the whole Region I, from the catalogue of Tassinari, among those houses that had at least one bronze vessel the average was 11.2 vases per house.⁷

The distribution of bronze vessels in Pompeian households has been discussed by Joan Berry and Bernhard Sigges. Both have calculated the number of bronze vases per square meter in a group of atrium houses; Berry has calculated an average 0.26 bronze vases/m² for the houses in her sample group (insulae I 7–I 9).⁸ Sigges presents the following table for the houses in his sample group (Table 2).⁹

	Surface m ²	Number of Bronze Vessels	Bronze Vessels/m ²
Casa dei Ceii	290	7	0.02
Casa di Paquius Proculus	1176	8	0.007
Casa delle Nozze d'Argento	1650	3	0.002
Casa del Principe di Napoli	260	28	0.11
Casa dell'Ara Massima	180	17	0.09
Casa di M. Lucretius	555	46	0.08

Table 2. Quantities of bronze vases in the houses analysed by Sigges 2002, with the addition of the House of Marcus Lucretius.

Sigges notes that this number, vases/m², is not a direct indicator of wealth, as the smaller houses tend to have a higher index of frequency for bronze vessels.¹⁰ In fact, there are indications that, to the contrary, higher status *hospitiae*, *cauponae* and bars may have had numerous bronze services crammed into relatively small spaces, and therefore the highest bronze vessel 'density'.¹¹ However, whether counting by numbers of single items, or by the space/vase index, the bronze vessels in the House of Marcus Lucretius are abundant and high in status.

Some remarks about the functional divisions of all the vases of the House of Marcus Lucretius should be made. By rough morphological-functional division, the largest group is relative to 'culinary consumption' (28), including tableware like small cups, plates, and spoons. In second place are vessels intended for 'pouring' (25), comprising jugs, ladles, and dippers, functional in the dynamic moving of liquids, serving, carrying them from one space to another, and transferring from one container to another.¹² The category of 'medi-

⁷ Tassinari 1993.

⁸ Berry 1997, 139.

⁹ Sigges 2002, 530.

¹⁰ Sigges 2002, 531.

¹¹ Berg 2018.

¹² Jugs in glass: two askoi (II.2.6, II.2.7, Cat. 127–128), in bronze, a handle of jug (Cat. 4), two two-handled jugs (186, 445–447); in terracotta, one jug called *olearo* (Cat. 204), one *piccolissima langella* (Cat. 486); amphorae (defined olla) (274, 303). Dippers with horizontal handle include five paterae (148, 218, 322, 358), one terracotta handle of a patera (21), three

cal/cosmetic' containers, i.e. unguent vessels and pyxides is notably high (24), and may be overrepresented in older excavations, considering the good chances of preservation of these relatively resistant small closed vessels. 'Storage' includes larger amphorae and larger glass bottles (over 15 cm) (14). 'Cooking' indicates vessels with a rounded bottom, often suspended, and lacking decoration (6). Often the cooking/storage cannot be separated by inventorial description ('ollae', 'pignatte') (9). Some cauldrons clearly served for heating water (1). The category of 'containing liquid' contains basins for ablutions, i.e. wide mouthed, low and large bowls standing on a stable foot (4), while food preparation only has two entries, a mortar and pestle (2).

II.1 Bronze Vessels

A considerable number of bronze vases or their parts (46) were found in the House of Marcus Lucretius, but only four have been located at the MANN.

Of the bronze vessels, 13 can be attributed to a prestigious banquet service.¹³ At the head of the banquet set are the large twin amphorae (H 27.5 cm), with richly relief-decorated and silvered handles. Both have been newly identified in the present research into the MANN collections as inv. 69469 and 69470; they were tracked down through a chain of inventory descriptions, helped by a detailed drawing of one of them in Niccolini 1854, pl. IV. The Dionysiac imagery of the handles, including the head of a wreath-crowned baby Dionysus, *syrix*, and fruit-chests indicate that the vases were used in a tricliniar context. They were defined in the *PAH* as 'olearia', which seems to be a name generally used for pelike-type wide and sagging or ovoid two-handled vases (II.1.1–2, Cat. 274, 303), and were found in the garden area over two consecutive days. They belong to the relatively uncommon type A1000 of Tassinari, and are rarely decorated not only on the handles, but also along the rim.

A notable prestigious feature of the bronze amphorae is, precisely, the fact that there were two. The aesthetics of twinned vases can be traced back to the symmetrically arranged banquet services on *kylikeia* tables in Etruscan tomb paintings.¹⁴ A good example of similar aesthetics in Pompeii is the *cartibulum* fresco of the tomb of Vestorius Priscus, with an equally symmetrical silver service.¹⁵ The preserved Pompeian silver services also obey the

casseruole (257, 359, 448), one funnel (187), two strainers, (50, 185), and one bucket (304).

¹³ Not counting the five cylindrical containers perhaps used for medical purposes. This is the maximum figure; it cannot be excluded that some vessels from the rear part of the house might have been confused with finds from neighboring houses.

¹⁴ For example, the Tarquinian tombs of Querciola I, Demoni Azzurri, and Tomba dell'Orco, see Guggisberg 2015, 188–189.

¹⁵ According to Isler-Kerenyi 2003, 46–47, twin vases were particularly common in Italy. For the tomb of Vestorius Priscus,

rule of symmetrical doubling, with the services of the House of the Menander and Villa of Boscoreale as prime examples, using them as a visual method to augment their status. Among Pompeian bronze vessels, the phenomenon of twin vases is particularly notable among larger jugs, both one- and two-handled. Since they have a larger capacity, they may not have been used for wine, but rather for pouring water to be mixed with wine during the *commisatio*. Analysing the vessels published by Tassinari, sixteen pairs of identical jugs (five amphorae and eleven pitchers) can be identified: the twinning is most common in types A3220 and B1200.¹⁶ In the collections of the MANN, the phenomenon is exemplified by several pairs of identical large jugs in bronze and silver.¹⁷

Other bronze vessels (not located at MANN) also called ‘oleari’ in *PAH* include ‘tre oleari co’manici dissaldati’ (Cat. 449–451). These may have been further, non-decorated vases of type A.

In the banquet set of the House of Marcus Lucretius, one of the most prestigious pieces was a bronze patera of Tassinari type H, with a ram-head handle, and a silvered decorative plate with a female head, probably Medusa, in low relief at the centre of the bowl (Cat. 148). The vessel can be considered unique among Pompeian finds, in particular because of the high quality of its central medallion. At present, however, only the silvered central medallion has been located in the MANN collections. The complete patera was studied at the MANN by Dwyer, who published a photograph in which the object is still complete, although showing some *lacunae* on the corroded bowl. Such paterae were used in ablutions, during banquets, or in ritual, to collect the water used for rinsing the hands, and was held in the left hand of a servant.¹⁸ The right hand would normally have held a jug for pouring water, normally a pitcher type D, with trilobed mouth, that forms a fixed couple with patera H. In the House of Marcus Lucretius, only one bronze handle found in the fauces R1 could be related to such a bronze pitcher (Cat. 4), as it is described in the *Inventario San Giorgio* as decorated at the lower attachment with a mask and a leaf, “con maschera giovanile e foglia”, decoration particularly common in pitchers of type D.¹⁹

Other ‘paterae’ have been preserved only through inventorial descriptions. Bronze dippers with one horizontal handle are a category of notoriously versatile nomenclature, and Sigges has clearly shown how varying the vocabulary for these vessel forms was in early Pompeian inventories. In our case, Cat. 257 has been called a ‘saucepan’ by Falkener, a ‘casseruola’ in the *Annali comunali*, a ‘cazzaruola’ in the *PAH*, but a ‘patera’ in *Registro Immissioni* and *inventario San Giorgio*. The most commonly used name for various dippers is ‘patera’, which can refer to Tassinari’s ‘patera H’, but sometimes also to ‘casseruola G’, or

Mols – Moormann 1993/94, 30–31.

¹⁶ Tassinari 1993. Casa del Criptoportico I 6, 2–16: A2000; Casa dei Quadretti teatrali I 6, 11: B1242; Bottega di Nirae-mius I 7, 18: A3220; Casa di Epidio Primo I 8, 14: A3220; Casa dei Quattro stili I 8, 17: A3220; Casa I 11, 6 B 1242; Casa I 11, 13 B1251; Casa I 18, 5: A3220; Casa di Arrius Crescens: III 4, 2 ‘lagoena’; Casa V 3, 2: B1222; VI 16, 32: Casa dei Poppaei: B1222; VI 16, 35: A3220; Insula Occidentalis B1222; B1222; B1251.

¹⁷ For example, two silver amphorae MANN 111768-11169 (h. 46 cm), see Guzzo 2006, 80, cat. 1 and 2.

¹⁸ Nuber 1972; Tassinari 1993, I, 232–233; Allison 2006, 21.

¹⁹ Tassinari 1993.

‘attingitoio da bagno I’.²⁰ For the House of Marcus Lucretius, four ‘patere’ are mentioned in the *PAH* (besides the Medusa-patera, Cat. 148, also 218, 322, 358). One of them (Cat. 322) has a diameter of 24 cm, and its handle is detached. Both the rim diameter, and the detail of the detached handle, and thus presumably a separately cast handle, suggest strongly patera H as its identification. The patera Cat. 218 also has its handle detached. The ‘patera’ Cat. 358 has a notably smaller diameter, ca. 16 cm, and is described as ‘rounded’, a ‘patera circolare’, and the vessel was also ‘broken at the handle’ – this might be, from the diameter, either a small patera H 2400, or a bathing dipper I, or even, but less likely, a large casserole G. As the handle is not detached, but broken, and the form is described as notably rounded, it might most plausibly be a dipper I, making it part of the hygienic/ablution utensils rather than banquet equipment. Thus, it can be suggested that at least paterae H, for banquet ablutions, and a third dipper, plausibly type I, were present in the house (Fig. 1).

Four ‘casseroles’ or ‘cazzaruole’ are listed among the finds from the house in the *PAH*. The primary supposition is that they belong to Tassinari’s category ‘casseroles’ G. Antiquarian interpretations saw these undecorated vessels, with one flat, perforated handle as ‘casseroles’ for cooking, but this function has been definitely ruled out by their lack of any burn marks; the current opinion sees them as multipurpose ladles useful in serving liquids.²¹ White, in particular, has associated the type with the ladle *trulla*.²² A probable

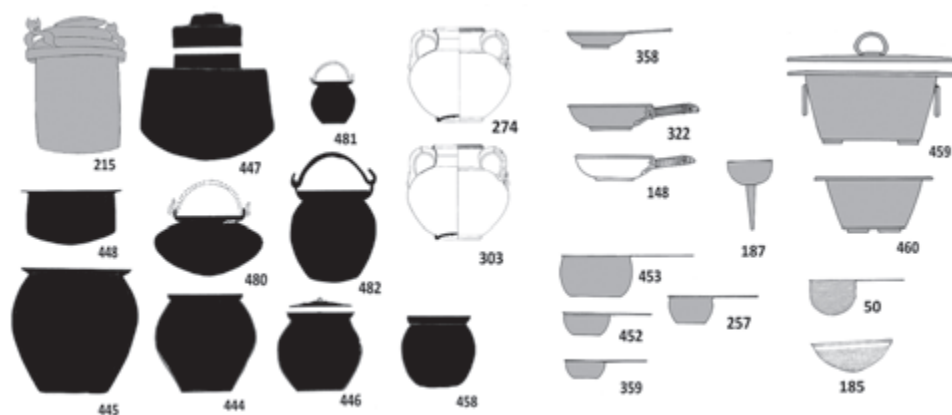

Fig. 1. A reconstruction of the bronze vases from the House of Marcus Lucretius: in white, the extant vessels; in grey vessels with known type and dimensions, in black vessels of which only very generic type and dimensions are known.

²⁰ The form called patera in Latin literature is certainly not the same as that referred to by the archaeological vocabulary. A patera was a *phiale*-type handleless and footless shallow vessel used for drinking and libating wine, see Hilgers 1969, 71–72, 242–245. See also Allison 2006, 21–22.

²¹ Tassinari 1993, I, 232–235; Allison 2004, 60–62; 2006, 25.

²² Radnóti 1938, 68; Boersterd 1958; White 1975, 192–193.

function for these vases is a ladle-measure, as they have a standardized series of (and sometimes internal) dividing lines.²³ Their role in the banquet would have been to measure wine and water for the individually mixed portions.²⁴

The ‘cazzaruola’ found in the garden area (Cat. 257), translated as ‘saucepan’ by Falkener, is described – without giving a diameter – as being ‘broken at the base’. This strengthens the hypothesis that the object is indeed most probably a ‘casseruola’ G, as the vessels of this category have a very thin bottom without a stand-ring, and thus are liable to break at base. The other three were found in the rear part of the house, without a more precise location given. One has a relatively small diameter (Cat. 359), (10 cm), typical of ‘casserole’ in category G. Two, of different measures, were found together, Cat. 452, (diam. 13.0 cm) and Cat. 453, which has a much larger diameter (20.8 cm), but was described in the *PAH* as being ‘similar to the previous one’; thus, here an identification as casserole G is again the most plausible, even if with such a diameter it would be among the largest ones extant in Pompeii. Thus, in sum, four casseruole G were plausibly found in the house (Fig. 1). Being the most common bronze vessel type in Pompeii, it seems to be an indispensable household object, both for utilitarian and display purposes, in use both in the kitchen and in the triclinium.²⁵

A further instrument for pouring wine should have been the bronze funnel (Cat. 187). Two strainers, also part of the prestigious banquet service, have differing forms. The first, which has not been located, is described as a ‘passabrodo’, or a ‘cullender’ with one handle (Cat. 50) and should belong to Category ‘colini’ K 3000 of Tassinari with one long horizontal handle, and decorated at bottom with ornamental perforations.²⁶ The other ‘cola-liquidi’ has been identified in the present research (II.1.4, Cat. 185), and belongs to Tassinari category M 2000 ‘colatoi’, the large bowl-like type. Interestingly, at the centre of the bowl a low relief image is impressed, not mentioned in any inventory. It shows a flying Cupid, and makes this find unique in Pompeii, and also ties it more closely to the representative pictorial context of the banquet. This vase completes the collection of 13 prestige vessels primarily intended for tricliniar use/wine service (two amphorae, three paterae, a jug, four ‘casseruole’, two colanders, a funnel).

A second, important group among bronze vessels is formed by the utilitarian vases for cooking, and for carrying and heating water.²⁷ One type is called ‘pignatta’ in the *PAH*. The word seems to be mostly applied to terracotta jars, but in five cases it is used for bronze vessels. The word should primarily refer to olla-shaped globular vases with a restricted, slightly out-turned mouth, but the it also seems to have been used in quite an indistinct

²³ Un esemplare pompeiano presenta, infatti, il suo interno segnato con cerchi incisi che dividono il volume in tre parti uguali, l'uso dei quali è sottolineato da incrostazioni di colori diversi in corrispondenza di essi (inv. P12865), Beretta – Di Pasquale 2004, 319, no. 4.32.

²⁴ Dunbabin 1993.

²⁵ Tassinari 1993, I, 232.

²⁶ Tassinari 1993, II, 160–161.

²⁷ For this group, see in part: Tassinari 1996.

way for kettles and cauldrons, simple cooking vessels, and also water-buckets of similar shape (*situlae*). A group of three ‘pignatte’ was found during the most hectic and confused excavation day, 30th August, in the rear part of the house. Only their respective heights were recorded as 25.5 cm (Cat. 444), 34 cm (Cat. 445), and 21 cm (Cat. 446), and they can only generically be referred to under the categories U ‘pentole’ or X ‘secchie’ of Tassinari. The lack of any mention of a handle, missing or not, would make the identification as a ‘pentole’ U more probable. One bronze ‘pignatta’ (Cat. 448), exceptionally described as cylindrical (D 26 and H 13) was found in an unknown location of the house. This could correspond to Tassinari’s category U1000, ‘pentola con ventre cilindrica’, a kettle for cooking.²⁸ A ‘pignatta col manico di ferro’, of height 24 cm, could also belong to this type; or, more probably, be an olla-shaped bucket with an arched iron handle, Tassinari X (Cat. 482).

The word ‘caldaia’ would have been used in the 19th century to describe larger round bottomed cooking vessels with a relatively narrow mouth, most probably boilers for water.²⁹ These should roughly coincide with Category V of Tassinari, called ‘caldaia’. Six such objects are listed in the *PAH*. The most notable (Cat. 215) is described as having two handles in a double dolphin form; its height, to the top of the lid, is ca 41.6 cm. Tassinari’s category ‘pentole con ventre troncoconico o cilindrico’ V 1000, with rounded bottom, high cylindrical body, and narrow neck, often have a lid decorated with dolphin figures, but cauldrons with two dolphin-shaped handles are not present in Tassinari’s typology. This vessel should belong to the tall, cylindrical, two-handled cauldrons interpreted by Anna Rocco as water-heaters, *miliaria* in the MANN collections (Fig. 1).³⁰ This vessel, and another, also a cauldron, were still attached to iron ‘fornelli’ (Cat. 458), or tripods. A third ‘caldaia’ present in the house (Cat. 447) was of exceptional height, 52.8 cm. Of the other three ‘caldaie’ found in the rear part of the house, their diameter is given – respectively 18.9 cm (Cat. 454), 26.4 cm (Cat. 480), and 13.2 cm (Cat. 481) – but not their height. Of the latter two, the documentation states that they were missing their handle – suggesting that their basic form would consist of a single handle. The larger of these three might have a form in which the diameter is larger than the height, with one transverse handle, i.e. Tassinari V 3000, a common type of cauldron with a lenticular body, a relatively narrow mouth, and one transverse arched handle; the average diameter of these vessels, intended to be suspended over the fireplace, is ca 25–35 cm. The two others, with small diameters, may have been smaller cauldrons of type U.

In sum, 11 vases can be suggested to be part of the cooking/water-heating service: three large boilers, four smaller cauldrons (type V/U) and four smaller kettles called ‘pignatte’ (U/W). None of these objects has been located in the MANN collections. The find spots of this category are unfortunately confused, as the largest bronze group was found on 30 August, when excavations were carried out in several places in the house, and possibly

²⁸ Tassinari 1993, I, 99–101. Of similar measurements, for example, 24–11 cm, is the smallest example of U1120.

²⁹ Allison 2006, 25.

³⁰ Rocco 2017, 17–18: type I; 246, fig. 3.

even in adjoining houses. According to Falkener, many bronze vases were found in the kitchen, proving its functional condition. A neat division can be seen in the locations of the banquet service, found in the main storage areas in the front part of the atrium zone, and the utilitarian vessels found in the servile areas and in the rear part of the house.

It has been impossible to identify the large vase (according to *Inv. San Giorgio*, H 26 and D 29) called ‘a two-handled *modius*’, ‘*modio con due manici*’ (Cat. 304), or even connect it with any known form. From the dimensions, it could indeed be a cylindrical *modius* measure, of ca 8.7 l, that are very rare among Vesuvian finds but may have been connected with the bakery activities present in the insula.³¹ A more common identification could be a ‘cylindrical bucket’ Tassinari form W1100.³²

Four vessels defined as ‘conca’ in the *PAH* can be interpreted as basins, but none of them has been identified in the MANN collections. A bronze ‘conca’ from R3/4 has a small diameter of only 23,5 cm, and might rather be classified as a bowl (Cat. 49). The ‘small oval basin’ found in the upper layers of the garden area R18, described as having two detached handles, is difficult to identify (Cat. 286). The two remaining bronze basins (Cat. 459–460) come from the large group of bronze vases with uncertain provenience. They are, however, the only vessels that can be defined as larger basins. Both are described as ‘conca bislunga’ in the *PAH*, both are furnished with handles and a lid (the lid is complete with a handle), with feet in the form of crescent, with dimensions respectively of H 20.8



Fig. 2.



Fig. 3.

³¹ Among the rare intact bronze *modii* from the Roman Empire is a *modius* from, Ponte Punide, with a capacity of 9.7–10 liters, D 22, H 27, Salazar 1913. One bronze *modius* was also found in Herculaneum, MANN inv. 6531/74600, see Roberts 2013, 56, fig. 48.

³² Tassinari 1993, II, 295.

and H 13.2, L 34.1. These undoubtedly belong to Tassinari type T, which she connects with ablutions (Fig.1). This type is interpreted by Sigges as a *matula*, and in his sample of five houses it is present in four; in three cases in or near the latrina of the house.³³ He also sees it as a strong sign of the inhabited status of the house. All in all, only 15 examples were catalogued as conserved from Pompeii deposits, meaning that this is a relatively rare form, evidently in use mostly in elite houses.

A small bronze vase defined as an 'olearia', with one (missing) handle, of ca 8 cm height (Cat. 186), from its scant height can only be an aryballos, Tassinari type F.³⁴ Together with the bronze strigil (Cat. 353) and the suggested bathing dipper I, discussed above, it would form a functional thermal bathing set. A cylindrical pyxis filled with sulphur should also be counted (Cat. 410) amongst the bronze toiletry items. All in all, seven bronze vases (two basins, two *matulae*, a dipper, an aryballos, a pyxis) would have formed the well-furnished hygienic equipment of the House of Marcus Lucretius.

Besides these 35 vessels discussed above, the remaining ten are defined too vaguely to be recognized, or consist only of handles.

Catalogue

II.1.1 Bronze amphora (Figs. 2–4, Cat. 274)

MANN 69470 (San Giorgio 8439).

Place of discovery: Garden R18 (May 25, 1847).

Dimensions: H 27.5; D rim 12.0; D base 11.4; D max 26.0, Th. wall 0.15.

Technique: Cast. Handles cast separately.

Condition: The vase is complete. The whole surface of the vessel is covered by a green patina.

Bibliography: Rocco 2017, 39. See Cat. 274.

Description: A vessel with two vertical handles and a spheroid body. The short concave neck is slightly offset by two grooves and a convex band. The rim is out-turned with a slightly pendant, thickened lip, which is decorated on the convex exterior by a continuous egg-and-dart pattern; along the upper edge of the rim runs a row of raised dots. The base, a low ring foot, is a separately cast piece, turned with a lathe, with four raised rings on the underside. The handles are richly decorated. The lower end of the handle presents the head of an infant, with rounded cheeks and curls flanking the face, wearing an ivy wreath; at top of the head the hair is bi-parted and tied with a ribbon. The head emerges from three pointed leaves,



Fig. 4. Niccolini 1854, pl. IV, 15.

³³ Sigges 526.

³⁴ Tassinari 1993 I, 48–50; II, 90–91; Allison 2006, 18.

above. On the middle part of the handle, three Dionysiac objects are presented, one on top of the other. The lowermost object is a rectangular base, on which a low plate with three rounded objects (fruit?), are placed. The second is a wicker basket in the shape of a *calathus*, from which a row of rounded and a row of triangular objects emerge; the basket lays on a horizontal line, from which a simple linear garland is hanging. The uppermost of the three objects is a pan flute, *syrinx*, set on its side; from behind it, on the right, a curved form emerges – this might be a *pedum*. Above, two elongated and pointed leaves part from a double band of raised dots, and reach towards the upper attachment.

Comments: The form corresponds in its general proportions (neck, handles) most closely to Tassinari A1000, two-handled jugs with a spheroid, somewhat flattened body (1993, I, 28; II, 1), although the form of the body, with the maximum diameter slightly larger in the upper part, the lower part narrowing towards the base, points to Tassinari A3121 (1993, I, 29; II, 3), which, however, have more elongated necks and handles. The form is quite rare; in Tassinari's catalogue only two whole examples of A1000, plus one pair of handles, are listed as recovered from the archaeological deposits of Pompeii (P3211 from I 7, 1; P2495 from V 3, 4, P2415 from V 3, 10). These do not present any decoration. Instead, several examples of A3000 have Dionysiac masks at the handles. Only a few handles in the Pompeian material are as richly decorated as these: three one-handled jugs of the form B1222 can be pointed out: inv. P3326 (Tassinari 1993, II, 29) has the head of a Satyr, a fruit basket, and a *syrinx*; inv. P18768, (Tassinari 1993, II, 30), a figure of a Satyr, a *calathus* with fruit, and a theatrical mask; inv. P10758 (Tassinari 1993, II, 35), a Satyr whipping a maenad, a *calathus* with fruit, a theatrical mask, a garland. First century BC to the first century AD.



Figs. 5–6.

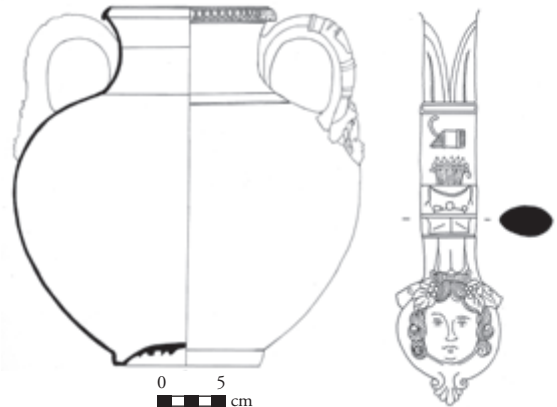

Figs. 7–8.

II.1.2 Bronze amphora (Figs. 5–8, Cat. 303)

MANN 69469 (San Giorgio 8440).

Place of discovery: Garden R18, possibly fallen from upper floors (June 8, 1847).

Dimensions: H 27.5; D rim 12.0; D base 11.0; D max 26.2; Th. wall 0.15.

Technique: Cast. Handles cast separately.

Bibliography: See Cat. 303.

Condition: Handles are detached, on the inside of the attachments there are silvery traces of soldering. There is a large horizontal breach on one side of the vessel, ca. 20 cm in length; part of the surface missing. The rim is slightly deformed and broken, and the upper edge of the lip is therefore discontinuous in places. The whole surface of the vessel is covered by a green patina, and at places with greyish encrustations.

Description: The vase is one of an identical pair, see above.

Comments: The form corresponds to Tassinari A 1000 with spherical body, see above.

II.1.3 Bronze patera (Figs. 9–11, Cat. 148)

MANN 73455 (San Giorgio 8438).

Place of discovery: Left ala (May 22, 1847).

Dimensions: D medallion 6.7; H medallion 1.1; Th. wall 0.2. According to Dwyer, the dimensions of the vessel were: H 1.9; D rim 20.8; L. handle 12.8. Of these, the height seems improbably low, as normally vessels with 20 cm diameter have a height of at least 4 cm.

Condition: The body and the handle of the vase have not been found in the deposits of the MANN. Dwyer found the vessel still whole, and published a photo of it, also giving its dimensions. In the photo, the body has some holes and missing pieces, and the surface is strongly corroded; it might have broken after the photo was taken. A copy of the object was made for the Field Museum of Natural History, which also has published a photo of it in the 1909 catalogue (Tarbell 1909, no 211).³⁵ An early photograph of the patera has been published in the posthumous volume by Anna Rocco 2017, 255, fig. 15 (Fig. 9). In the catalogue *Domus Pompeiana*, an associated handle was published together with the medallion, but a closer comparison with the preserved photo has revealed that this cannot be the original handle. All three parts were already detached at the moment of discovery, and they had been restored at the museum. Only the detached decorative medallion



Fig. 9.

can at present be identified with certainty. It is intact, with some superficial corrosion on the cheeks of the figure; some locks of hair still present traces of the original silver coating.

Bibliography: Tarbell 1909, no 211; Dwyer 1982, 32, i, fig. 15; *Domus pompeiana* 2008, 113, fig. 8.4; Rocco 2017, 255, fig. 15. See also Cat. 148.

Description: In Dwyer's photo, the object is complete with bowl, and shows a low basin with slightly out-turned rim, a cylindrical handle with ribbed stem, and a convex moulded band at both ends;

³⁵ In this catalogue entry, Tarbell interestingly notes that the open mouth of the Medusa figure would impede the practical pouring of liquids from the vase, and presumes it is only a decorative piece. However, the mouth may have originally been filled with some substance to allow its use.

the finial is in the form of a ram's head. The still extant central medallion is a separately cast piece, in the form of a convex disc, with hollow interior. It presents in low, finely worked relief a protome of Medusa, with classical, melancholy but not non-grotesque features. The eyes are large, the mouth is open and perforated. The loose hair, composed of separate disordered locks (no snakes), is tied above the forehead with a simple band; the hair fills the surrounding space of the tondo. An identification as a maenad could also be proposed.

Comments: The Pompeian paterae with handle ending in ram's head all belong to low bowls with discontinuous base, i.e. Tassinari's Category H 2000 (I, 58–60; II, 132–141). Although the H type paterae are quite common in Pompeii, only very few have central relief decoration. Tassinari published three such examples from Pompeii, all of type H2322 (II, 139, depicting mythological figures, inv. P1928, P10282, P11654). None has a Medusa head at the centre, although such an apotropaic element appears on some *fulcra*, jug handles, and water basins. A patera H at Pompeii Archaeological Storerooms has a Medusa head as a filial of the handle (P13384, Tassinari 1993, II, 149). A patera H in the British Museum (inv. 1882,4–5.1) has a Medusa head, albeit in higher relief, and with snake heads, at the centre. However, the identification of the figure as Medusa is not completely certain, as it does not present neither snakes nor wings in its dishevelled hair. First century AD.

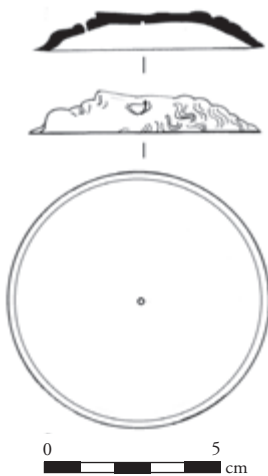

Fig. 10.



Fig. 11.

II.1.4 Bronze strainer (Figs. 12–14, Cat. 185)

MANN 77603 (San Giorgio 2670).

Place of discovery: Kitchen area R11–14 (August 13, 1847).

Dimensions: H 7.2; D rim 23.0.

Condition: About two-thirds of the vase are preserved. The whole surface is covered by a strong green patina, blue in some spots; the exterior is particularly rough with corrosion, the interior is smoother and better preserved. On the interior, and the upper part of the exterior, there are several spots of grey, mortarlike encrustation. There are two breaking lines at the centre of the interior, crossing the



Fig. 12.

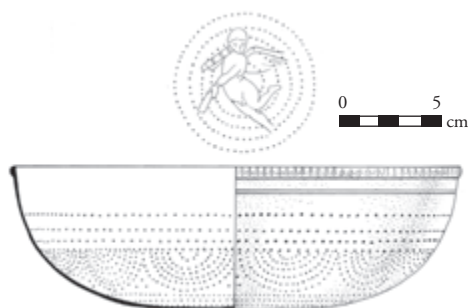

Fig. 13.



Fig. 14.

relief. The vessel surface is slightly deformed.

Bibliography: See Cat. 185.

Description: A hemispherical bowl, with a narrow, concave moulding on the exterior of the lip; the moulding is decorated by an egg-and-dart motif in relief. Below the moulding, an incised double line. Perforated holes over all the surface except for the uppermost third. At the central part of the body, three parallel, concentric lines of perforation; below, the perforated holes are arranged in semi-circular figures, each formed by six parallel diminishing lines of holes. At the bottom, around the centre of the vase, eight concentric circular lines of holes. The central point is left without perforation, and is decorated by a very low relief, hammered with repoussé technique, further retouched by engraving. The relief shows a nude Cupid, flying to the left, with backward-turned face; one wing is visible, and the left foot is bent upwards at the knee to suggest its hovering position. The Cupid holds an elongated object, probably a torch, against its right shoulder; the left hand, adorned with a bracelet, holds another object turned downwards.

Comments: The strainer belongs to the Tassinari category M2000, comprising strainers in the form of a bowl with slightly curving convex wall (1993, I, 79; II, 168). They also normally have a ring for suspension, missing in the present example. The lip is different from the Pompeian examples. The general form, with a relatively flat bottom, resembles most closely M2200, even though the walls are not straight/inward tapering, but rather sloping outwards like in M2100. None of the Pompeian examples has a similar pattern of perforation. First century AD.

II.2 Glass Vessels

There were 43 glass objects found in the house in total. Besides vases, one glass paste bead or counter (Cat. 478), a decorative disc (III.4.3, Cat. 400), and a group of window glass/talcum pieces (Cat. 130) were found. The vessels comprised 39 relatively complete vases, and a group of non-quantified glass shards (Cat. 135). The glass vessels included 13 items classifiable as tableware (7 cups, 2 cups with pedestals, 2 jugs, 1 plate, 1 spoon), 21 medicinal/cosmetic unguent bottles, and 5 storage containers (large bottles with handles).

Of the tableware, ten items have been located at the MANN and studied. These include seven elements of a remarkably uniform table service in colourless glass, turned white by iridescence.³⁶ The pieces were produced using the rare techniques of casting or mould-blowing, and subsequent refining by relief cutting, grinding, and incision. Such techniques appeared for the first time in the Neronian period, and the Vesuvian examples are thus relatively early.³⁷ The two mould-blown and relief cut askoi (II.2.6, II.2.7, Cat. 127–128), two *acetabula* with pedestals (II.3.1, II.3.2, II.3.3, II. 3.4, Cat. 90–91) and the cantharus (II.2.9, Cat. 193) are of a quality rare among Vesuvian glass finds, and indeed among Roman glass in general.³⁸ Thus, the glass table ware of the House of Marcus Lucretius is to be considered a very precious banquet set, possibly a substitute for a silver service, as it is comparable with it in price, or an alternative summer service (*vitrum aestivum*).³⁹ Notably, morphological parallels for all of the forms can be found among silver ware, but not glass vessels.

Three additional, located pieces of the table service were manufactured in coloured glass by casting blanks and grinding, an earlier production technique datable to the first half of the I century AD, thus being already quite old at the time of the eruption.⁴⁰ These include an emerald coloured and lathe-turned plate (II.2.10, Cat. 332) and a very small cup (II.2.9, Cat. 193) and a blue spoon (II.2.5, Cat. 92).

The glass cups or small dishes were originally nine in number, including the five located pieces mentioned above. Unlocated cups included the base of a glass cup ‘coppa’ (Cat. 35), a cup, ‘coppa’, broken on the side (Cat. 265), and a fragmented cup, ‘tazza’ (Cat. 363). A cup in blue glass, evidently decorated with vertical relief ribbing (Cat. 126), cannot be located at the MANN, but can be followed in the inventories at least up to San Giorgio (inv. 2800), “frammenti di una tazza di vetro color bleu”. It should be identical to MANN inv. 12246: “Tazza di pasta vitrea bleu scanalata: è tutta frammentata.” All in

³⁶ The two *acetabulum*-and-pedestal pairs are catalogued together in the Appendix.

³⁷ Harden 1987, 181; Scatozza Hörich 2012, 47, in part. n. 13, discusses the appearance of colourless glass and engraved relief vases among Pompeian finds; several production techniques have been proposed for them.

³⁸ von Saldern 1985; 1991; Price – Cottam 1998, 83; Cool, forthcoming; Scatozza Hörich 2012, 45, and 37, pl. C: mould-blown and mould-pressed glass vessels form an absolute minority among Pompeian glass finds.

³⁹ On other proposed glass services found in Pompeian houses, see Scatozza Hörich 2012, 31–32. *Vitrum aestivum*: Ps. Verg., *copa*, 29.

⁴⁰ Grose 1999; Petrianni 2003.

all, that word ‘tazza’ seems to have been preferred for more open forms, e.g. plates/bowls, while ‘coppa’ refers to more closed cups.

A difficult but important question concerns the division of glass bottles into those mainly used for storage and unguent bottles. The latter are small, narrow-necked, and without handles, while storage bottles commonly have handles and are higher – but it is difficult to draw an exact division line between them. In this study, besides the small *ampullae vitreae*, the spherical long-necked bottles up to ca 15 cm of height have also been counted as unguent bottles.

The most clear-cut types of storage bottles for oil, wine, and other liquid foodstuffs are the forms Isings 51 (cylindrical) or Isings 50 (rectangular base), with one handle and a short narrow neck, ca 20–30 cm high. Four non located bottles have putatively been thus identified as Isings 51: two bottles found in cubiculum R6 (Cat. 132–133), height ca 26 cm or slightly more, one of them interestingly described by Falkener as having had remains of a wicker work covering, of which he made a plaster cast.⁴¹ Two are described as ‘bottiglia bislunga ad un sol manico e col collo corto’ (Cat. 177, 330), the former 13.2, and latter 26.4 cm high.

All in all, 21 glass vessels have been classified as unguent bottles, but none of them has been located. The vocabulary describing unguent bottles is generally rather ambiguous and variable. The word ‘lacrimatoio’, ‘lachrymatory’, has been used in the *PAH* only once (Cat. 16), for a glass bottle 8.8 cm high, most plausibly referring to the tubular or drop shaped small bottle of type Scatozza Höricht 47a (Fig. 15). This form has a long neck with a constriction at its base, an out-turned rim with a sheared edge, and is often unable to stand without support for its rounded base.⁴²

The word unguentarium is used seldom in the *PAH*: only in the case of four small glass vases found in the recess of upper atrium R29 (Cat. 392–395). In this case, both the *PAH* and Falkener use this word.

Besides these, only one terracotta vase (Cat. 42) is defined as ‘un piccolo vasettino forse unguentario’, translated by Falkener (45, n.) as an ‘ointment vase’. The rarity of this word makes it clear that other expressions must also have been used for unguent bottles. In

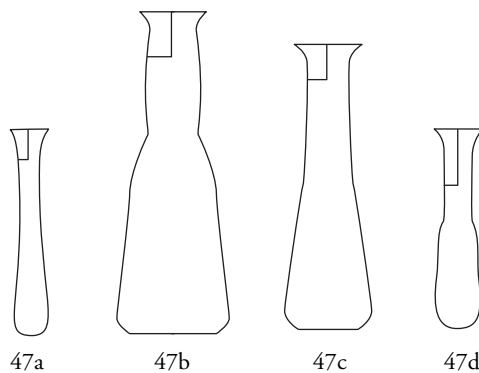

Fig. 15. Unguent bottle of Scatozza type 47.

⁴¹ We have pictorial and textual evidence for such wicker coverings, mostly for terracotta vases (cf. *urnas sparteas*, mentioned in Cato *agr.* 11.2), but also for glass vessels, namely *lagoenae*, Mart. 2.85, Hilgers 1969, s.v. *lagoenae*. Further, see Cullin-Mingaud 2011, 220–221.

⁴² On tubular unguentaria in Pompeii: Allison 2006, fig. 13.11–19; Cool 2016, 59–60.

the above-mentioned case, Falkener speaks of five unguentaria, and the *PAH* of four unguentaria and one ‘caraffinetta’ (Cat. 365). In fact, in the mid-19th century, the most common expression for the glass unguent bottles seems to have been ‘caraf(f)inetta’. Hypothetically, these might belong to the most common forms of unguent bottles in Pompeii, Isings 6 / De Tommaso 12 / Scatozza 46⁴³ (Fig. 16). This word is used, for example, for the glass bottle of undefined height, Cat. 399, a possible unguent bottle, of which hardly anything more can be said. In one case (Cat. 192), a vase called ‘grossa caraffinetta a palla’ seems to be later given a height of ca 8 cm in the *Inv. San Giorgio*, but here a mix-up of numbering hinders certainty. This can, however, be presumed to be a bulbous or spherical unguent bottle Scatozza 41 or 45 (Fig. 16)

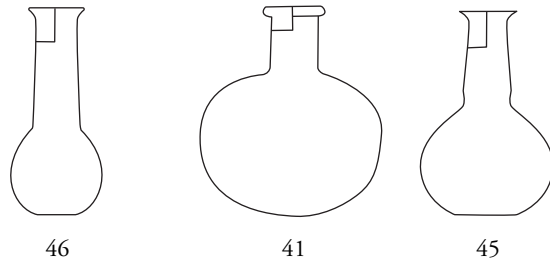

Fig. 16. Scatozza unguent bottle types 46, 41 and 45.

However, the translations given by Falkener for glass ointment bottles vary from case to case: a group of five ‘caraffinette’ ‘of different shapes’, in the *PAH* (Cat. 85–89) is translated as ‘small jars’. A ‘caraffinetta’ ca. 8 cm high (Cat. 178) is a ‘long-necked bottle’. Once, the word ‘caraffinetta’ has even been translated by Falkener as a ‘cup’ (Cat. 7). The word ‘caraffinetta’ thus seems to include different types of unguent bottles, from the bulbous De Tommaso 12 to the types of more cup- or olla-like forms, such as Isings 67.

Another expression that quite certainly refers to unguent bottles is the morphological definition ‘a palla’ given to various larger glass bottles (indistinctly ‘bottiglia’/‘boccia’), which should refer either to the previously mentioned, smaller bulbous forms, or to the larger De Tommaso 32/Scatozza 42/49,⁴⁴ with low spherical body, relatively high vertical neck, and medium height of ca 15 cm (Fig. 17).

Thus, we find two smaller bottles, a ‘piccola bottiglia a palla’ (Cat. 348) and a ‘piccola boccia a palla’ (Cat. 391, translated by Falkener as ‘small spherical vase’); and larger ‘bocchetta a palla’, height 10.4 cm (Cat. 331), *idem* ‘col manico’, height 12 cm (Cat. 264) and ‘bottiglia a palla’ of height 13.2 cm (Cat. 176). A borderline case is a large spherical bottle with two handles, ‘boccia a palla a due manici’, of the height of 18.9 cm (Cat. 398), which considering its spherical form has been interpreted here as an unguent bottle, but could also have had a diverse function.

⁴³ Scatozza 1986, 57–58; De Tommaso 1990, 46. For numerous parallels, see for example: Beretta – De Pasquale 2004, 264, cat. 2.117–122; Allison 2006, fig. 13.1–10. For the most common forms of unguentaria in Pompeii, see Scatozza 2012; Cool 2016, Appendix 3.

⁴⁴ De Tommaso 1990, 58–59. The type was also produced in the Vesuvian area, see Scatozza 1986, 64. For numerous parallels, see for example: Allison 2006, 163–164, cat. 1071–1072; fig. 12.

Of these putative unguent bottles, two major concentrations can be discerned, and very likely they refer to storage patterns: the above-mentioned group of six examples in R29, of which at least four were found in the cupboard recess. The second concentration of five small bottles was found in the front cubiculum area R4(3), together with the majority of high value finds from the house. In the same room, three pieces of blue pigment were found, described in the inventories as a cosmetic substance (Cat. 95). Four examples, including the possible bronze aryballos, were found in (the upper layers of) the servile quarters R11–14, two in cubiculum R30, a room decorated with rich wall-paintings and opening onto the upper atrium (Cat. 398–399) together with a glass medallion (III.4.3, Cat. 400), they were found possibly an ornament of a toiletry box and the latter might well be a use-context. In the last context, cubiculum R32, also opening to the upper atrium, other toilet utensils were also found, including a cylindrical bronze vase, 5 cm high and diam. 6.5, containing sulphur (Cat. 410), quite probably a pyxis that originally had a lid. The rest were single finds (R1, R1 top layers, R2, R18, R25).

All in all, the glass vessel assemblage of the House of Marcus Lucretius has proved to be very rich. On one hand, the total of 21 unguent bottles is a relatively high number among atrium houses. On the other hand, the high-quality banquet service is composed of colourless and relief decorated vessels of truly outstanding and luxurious quality. Furthermore, some remains of an earlier service in cast and cut blue and emerald coloured glass also seems to have remained in use in the House of Marcus Lucretius.

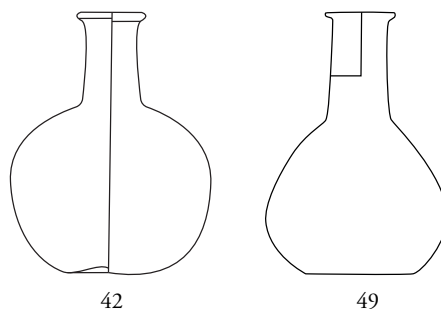

Fig. 17. Unguent bottle types 42 and 49.

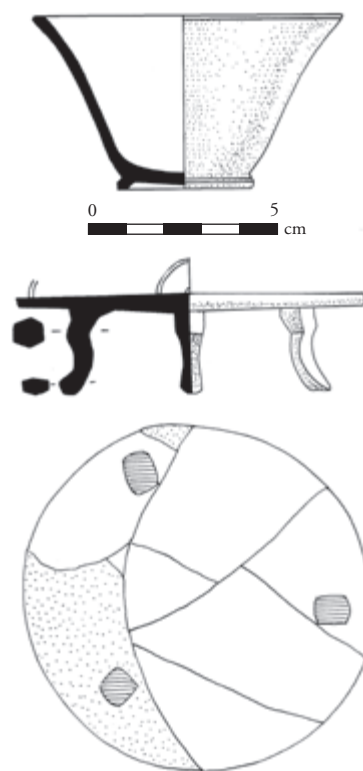

Fig. 18.

Catalogue

II.2.1 Glass cup (*acetabulum*) (Figs. 18–19, Cat. 90) MANN 11668 (San Giorgio 2793).

Place of discovery: Cubiculum R4/R3 (March 23, 1847).

Dimensions: H 4.8; D rim 8.6; D base 3.7.

Technique: The blank vessel, possibly cast, has been finished by turning on a lathe, as is revealed by numerous circular horizontal lines on the body, on both the interior and exterior.

Condition: Integrally preserved. Small micro-breakages inside glass in the base. White, opaque patina on all surfaces; iridation in places. On the interior surface, a band of greyish, sandy encrustation; also present under the base.

Bibliography: Dwyer, 27, x–xiii, fig. 11; Berg 2008a, 104–105, fig. 8.1d, see also Cat. 90.

Description: A cup in colourless glass. The cup stands on a low, full ring foot that is convex on the exterior. The body is sloping, slightly concave, flaring outward in the upper part, the lip is rounded and slightly out-turned.

Comments: The shape of the cup corresponds roughly to Isings form 49. Scatozza Höricht (1986, 36) discusses a similar type in Herculaneum as form 11, ‘tazza trococonica a profile concavo’, which has, however, a less pronounced foot and is produced by blowing (for example inv. E756, 36, 33, pl. XIII). She compares the type with forms in silver, and in this case the parallel is particularly suitable, as these silver cups are often accompanied by similar pedestals. The form can putatively be recognized as an *acetabulum*, a cup for vinegar sauces, and also a liquid measure. Middle of the first century AD.

II.2.2 Glass pedestal (*mensula*) (Figs. 18, 20, Cat. 90) MANN 11669 (San Giorgio 2793).

Place of discovery: Cubiculum R4/R3 (March 23, 1847).

Dimensions: H 2.7; D 9.5.

Technique: The disc is pressed. The disc has then been turned on a lathe, the feet carved to sharpen their form.



Fig. 19.



Fig. 20.



Fig. 21.

Condition: Reconstituted from six fragments; ca. one-fourth has been reconstructed from white gypsum, in which the third foot has been inserted. Colourless, transparent glass, that has turned white and opaque with iridescence on most surfaces.

Bibliography: See Cat. 90.

Description: The pedestal, in colourless glass, is composed of a flat horizontal glass disc, with rounded edges, resting on three S-curved feet, rectangular in section, thinner at base. On the top of the plate two concentric grooves, one D 9.0, along the edge, the other around the central point, D 1.5.

Comments: There are not many parallels for the glass pedestals (cf. the rectangular form 61 of Scatozza Höricht), but several parallels can be found among tripod silver *mensulae* (for ex. Guzzo 2006, 214, cat. 313–316 from the Menander silver hoard).



Fig. 22.

II.2.3 Glass cup (*acetabulum*) (Figs. 21–22, Cat. 91)
MANN 11666 (San Giorgio 2794).

Place of discovery: Cubiculum R4/R3 (March 23, 1847).

Dimensions: H 5.4; D rim 9.9; D foot 4.4.

Technique: The vessel has probably been cast into a mould and finished by turning on lathe, as is revealed by numerous horizontal lines on the body, inside and out.

Condition: The cup is preserved intact, but has become opaque and white with iridescence.

Bibliography: See Cat. 91.

Description: A cup in colourless glass. The cup stands on a low ring foot, that is convex on exterior. The body is sloping, flaring outward in the upper part, the lip is slightly out-turned.

Comments: See above MANN 11668.

II.2.4 Glass pedestal (*mensula*) (Fig. 21–22, Cat. 91)
MANN 11667 (San Giorgio 2794).

Place of discovery: Cubiculum R4/R3 (March 23, 1847).

Dimensions: H 2.7; D. 9.1; Th. plate 0.3.

Technique: Cast and ground.

Condition: Preserved intact.

Description: The pedestal is composed of a flat horizontal glass disc, resting on three S-curved feet, thinned at base.

Comments: See above MANN 11669.

II.2.5 Glass spoon (Figs. 23–24, Cat. 92)
MANN 12086 (San Giorgio 2797).

Place of discovery: Cubiculum R4 (March 23, 1847).

Dimensions: L. (pres.) 6.3; L (bowl) 6.0; W 4.1.

Technique: Cast and ground.

Condition: The handle has broken off, and of it only a stub of ca. 2 mm remains. The bowl is intact except for a small piece that has flaked off at the tip of the bowl.

Bibliography: Dwyer, 28, xx.

Description: Bowl of a spoon in dark brownish glass, quadrangular in section. It is made of dark, brownish glass, mostly covered by a white opaque encrustation. The form is oval, slightly thinned at the tip.

Comments: Spoons were rarely made in blown glass; cast and ground examples are very rare. First half of the first century AD.

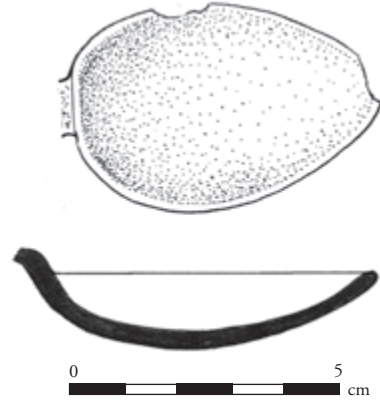

Fig. 23

II.2.6 Glass askos (Figs. 25–26, Cat. 127)

MANN 12008 (San Giorgio 2791).

Place of discovery: Cubiculum R6 (March 23, 1847).

Dimensions: H 13.0; L max 15.5; W 10.0; D foot 6.5–5.0; D mouth 9.0.

Technique: The vessel is mould-blown, as the convex ribs on the exterior are mirrored as concavities on the interior; the outlines of the ribs and the low ring foot have been finished by cutting, and the handle by engraving.

Condition: Complete after reconstruction from fragments. White opaque patina and some iridescence on surface.

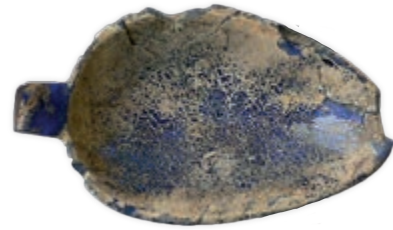

Fig. 24.



Fig. 25.

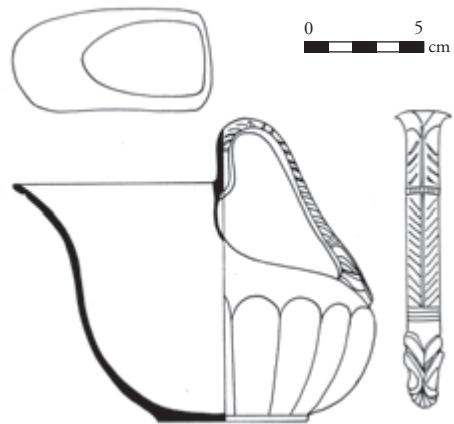

Fig. 26.

Bibliography: Dwyer, 30, iii–iv, fig. 12; Berg 2008a, 104–105, fig. 8.1.a. See also Cat. 127.

Description: Colourless glass. Very low ring foot, bulbous body, wide mouth with flaring rim, just under the lip; on the exterior, an incised line. On the lower body, large convex relief ribs or petals. High, arched strap handle has incised decoration on the exterior: in the central area, an incised herring bone motif, and cut volute mouldings at the base.

Comments: Belongs to general type Isings 59, askoi, that are mostly in blown glass. The refined production technique makes this couple of askoi a unique in the Vesuvian area. Middle of the first century AD.

II.2.7 Glass askos (Figs. 27–28, Cat. 128)

MANN 12010 (San Giorgio 2792)

Place of discovery: Cubiculum R6 (March 23, 1847).

Dimensions: H 12.7; L max 15.5; W. 10.0; D foot 5.5–7.0; D mouth 8.7.

Condition: Preserved intact, except for a small piece broken off from the beak. Originally transparent, colourless, slightly greenish glass is covered by white, opaque patina on all surfaces.

Bibliography: Spinazzola 1928, pl. 228; Isings 1957, 77; Ziviello 1986, 224, Cat. 39 (as inv. S.N.). See also Cat. 128.

Description: See II.2.6 above.

Comments: See II.2.6 above. Ziviello calls it “one of the most refined examples of such askoi”.

II.2.8 Glass beaker (Figs. 29–31, Cat. 129)

MANN 11984 (San Giorgio 2798)

Place of discovery: Cubiculum R6 (March 23, 1847).

Dimensions: D rim 13.4; pres. H 7.4.

Technique: Blown or cast blank, finished by cutting, engraving and polishing. Grooving marks on interior and exterior.



Fig. 27.

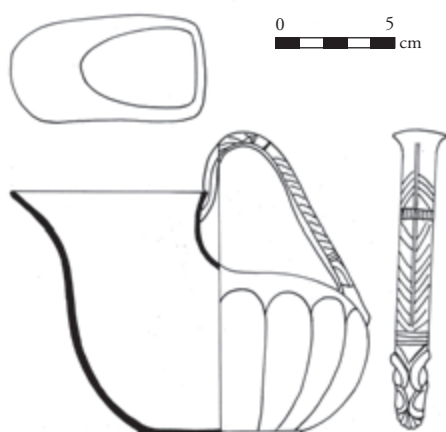

Fig. 28.

Condition: The vessel is broken in eight fragments, four joining and four non-joining. All of the rim is conserved; one of the two handles is complete, the other missing, only the attachments are preserved. The lower part of the bowl and the foot are missing. The white glass is dimmed in places, in other places transparent.

Bibliography: See Cat. 129.

Description: A shallow hemispherical cup in mould-pressed white glass. The rim is plain, slightly curving inward. On the interior, an engraved line just under the lip. On the exterior, relief decoration in the form of pointed leaves, in two superimposed rows of four leaves each. In the upper row, the leaves are alternately turned left and right, in the lower row they alternately point up and down. The handles have as their lower attachment an ivy leaf, pointing downward. The upper attachment is at the rim, and at its two sides the rim had been modelled with undulating, decorative cuts. The narrow strap handle arches high over the level of the rim. The handle is decorated with incised lines, two long vertical lines at the centre, and horizontal double grooves at the top and bottom.

Comments: The fragments were found in the MANN storage rooms without inventory numbers (s.n.). However, the form, decoration, and dimensions of the vase correspond exactly to *Inventario Fiorelli* (diam. 135). Minervini 1854, pl. IV, 4 presents a drawing of a 'graziosa tazzolina' in white glass, identical in form to the present object. The rarity of this type of glass vessel makes the identification very probable. In this case we can recognize its form as a cantharos. A pair of similar mould-pressed white glass cups, with similar relief decoration of pointed leaves, but on a low foot, was found in the Casa della Caccia dei Tori, MANN 133274 (*NSc* 1908, 276–277, Tav. 4, 4a, von Saldern 1985, 32 no. 6, Taf. 5). For such vases, that form a rare group mostly datable to the third quarter of the I century AD, see von Saldern (1985, 1991). Price – Cottam 1998, 83. Similar relief decorated wares come from military sites of the Northern limes area. A glass amphora/pelike of colourless glass, with similar raised leaf patterns was found in Cologne, Bonner Strasse (Römisch-Germanisches Museum Köln, inv. glas 967), and is datable to the second half of the I century AD, Harden 1987, 191, cat. 101, with parallels. This

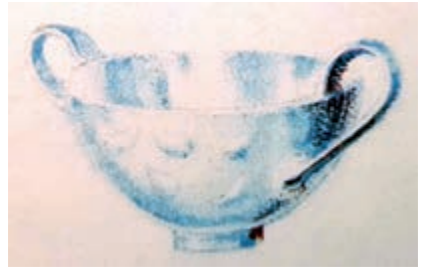

Fig. 29. Niccolini 1854, pl. IV, 4.



Fig. 30.

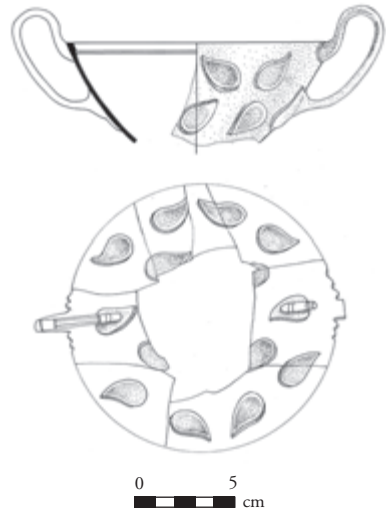

Fig. 31.

amphora also presents on its handles incised herring patterns similar to that seen in the two glass askoi of the House of Marcus Lucretius (see above).

I thank Hilary Cool for pointing out three close parallels for the beaker, found in Roman Britain, and relative bibliographical references. The first in course of publication, comes from Scotch Corner excavations.⁴⁵ The second was found in Fishbourne, in a habitation of very high status possibly with royal connections, of Neronian date (Harden and Price 1971, 332–334 no. 29, fig. 138). The third comes from Silchester, Insula IX, and is of Neronian – early Flavian date, see Cool, forthcoming. Cool suggests that such vessels, that shared the production technique with extremely valuable stone, murrhine and rock crystal vases, were certainly considered luxurious item and may have arrived into Britain as diplomatic gifts. Middle of the first century AD.

II.2.9 Glass cup (Figs. 32–33, Cat. 193)

Place of discovery: Kitchen area R11–14 (August 13, 1847). MANN 13633 (San Giorgio 2808).

Dimensions: H 2.5; D rim 3.8; D foot 2.4.

Technique: The vessel has been pressed into a mould or cast, and then polished by turning on lathe, as is revealed numerous horizontal grooved lines on the body.

Condition: Intact, except for minor flakes broken off the lip. Interior and exterior surfaces covered by a strong, whitish, flaking stratum of iridescence.

Bibliography: Dwyer, 34, xiv.

Description: A miniature cup in dark green transparent glass. Walls are strongly convex, inverted towards the rim. Lip is thinned, plain, rounded, the vessel stands on a low ring foot.

Comments: The cup does not belong to common forms in Vesuvian glass. No similar cup is found among Scatozza's Herculanean or Pompeian examples (1986, 2012). The cup belongs to Grose's Family III of Roman Cast Monochrome Vessels (Grose 1989, 254, fig. 135) and Petrianni's Gruppo II, equated with Isings 20 (Petrianni 2003, figs 85/6). First half of the first century AD.

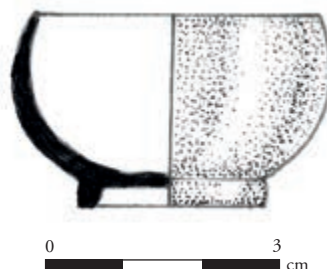

Fig. 32.



Fig. 33.

II.2.10 Glass plate (Figs. 34–35, Cat. 332)

MANN 11646 (San Giorgio 2814 or 2813).

Place of discovery: R 19–20 (September 6, 1847).

Dimensions: H 2.7; D rim 17.5; D foot 10.3.

Technique: The vessel has been pressed into a mould or cast, and then polished by turning on lathe, as is revealed numerous horizontal grooved lines on the body.

Condition: Preserved intact; the surface is partially covered with irided areas of beige colour and bluish spots.

Bibliography: See Cat. 332.

⁴⁵ See Cool (forthcoming).

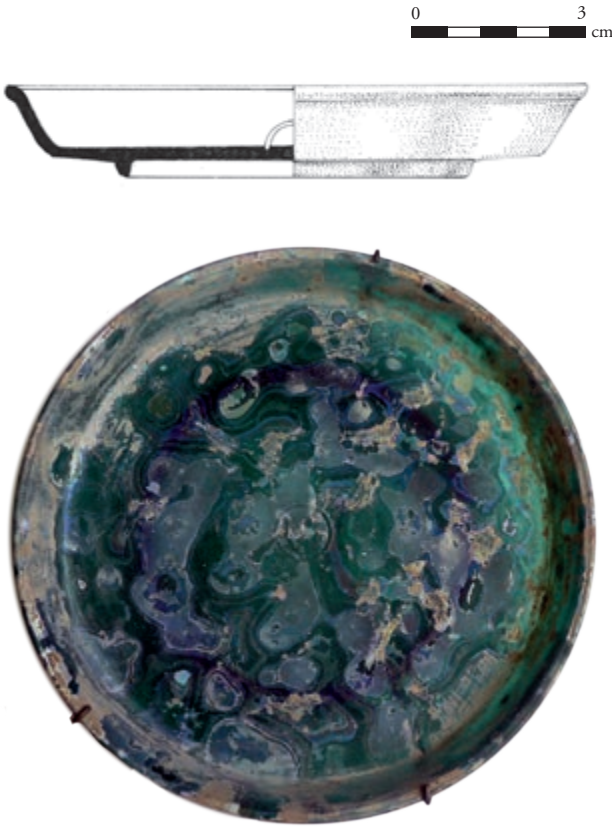

Figs. 34–35.

Description: A low plate in green transparent glass. The foot is low with straight sides, the well is horizontal, wall sloping, the rim a slightly everted bead-rim. The lip has an engraved grooved line on the interior; there is another incised circular line at the centre of the well (diam. 2 cm).

Comments: Form Isings 47, Scatozza 4, datable first half of the I century AD. Scatozza discusses such mould-pressed/cast plates (1986, 31–32, pl. XXV) on the basis of two fragmentary examples from Herculaneum, one in dark green glass, finished turning with lathe (inv. E2796), the other, similar, in dark blue glass (E2930). For technique, see the discussion in Harden 1987, 45, cat. 21; Grose 1989; Petrianni 2003. First half of the first century AD.

II.3 Terracotta Vessels

Terracotta vases (or their parts) form 48 entries in the present catalogue. As stated above, this low number quite evidently represents only a portion of the original number of vases, emphasizing those with some particular features. Only one has been located at the MANN.

Among the specimens listed in the records, the largest group is formed by vessels used for dining at the table, i.e. small, open forms for eating or drinking, such as cups, mugs, and plates, 29 in number. Of these vessels, 15 were named ‘bicchiere’, ‘coppa’, ‘tazza’ or ‘tazzolina’ (Cat. 2, 3, 75–77, 233, 266, 333–334); they appear to be without handles, and have consequently been classified as cups in the present catalogue. Small vases with

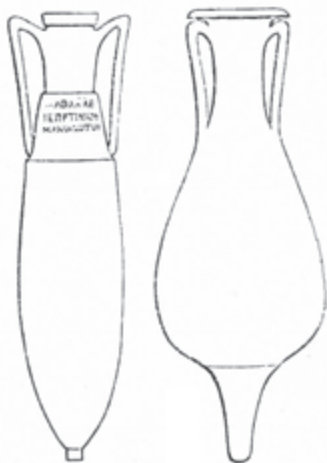

Fig. 36. Falkener's drawings of two transport amphorae, 1852, 79 (Cat. 346, left, and Cat. 347, right).



Fig. 37. A parallel to the titulus of House of Marcus Lucretius amphora might be CIL 2577: *G.F. scombri | ..on | [ex] officina Scaur[i]*. The uppermost row of a similar, worn text would have been read TVSCOLA.

handles, called 'pignatte/pignattini con manico', are classified here as mugs (Cat. 73–74, 179, 180, 202, 290). Most probably the latter category coincides with thin-walled ware one-handled mugs, although the identification of the last two, Cat. 182–183, defined only as 'vasettini privi di manico', might also be larger ollae for storage.

Other than these, only very vague information about the pottery fabrics can be derived – all in all, five have been described as covered with red slip, and are presumably of terra sigillata (Cat. 2, 75–77, 364). Three of these (Cat. 75–77) were found together in the main deposit room R3/4, and one of them (Cat. 76) containing barley. Only one has been described as being stamped, the plate with the *plantapedis FORTVN* (II.3.1, Cat. 364), and this item has also been located in the MANN.

Besides cups, plates ('piatti') appear quite rarely in the *PAH*, and only once in connection with terracotta: a plate containing olives (Cat. 349), found together with a dish of olives (Cat. 350) in R25: "Molte olive carbonizzate in un piatto di terracotta ed altre in un recipiente a forma di conca". The latter has a diameter of 26.4 cm, and can be classified as a bowl.⁴⁶ Among serving vessels, only two pitchers in terracotta were listed in the inventories: a small, even miniature jug, height only 8 cm, 'piccolissima langella' (Cat. 204), and another one called an oil-flask with a handle, 'olearo ad un manico', possibly a *lagoena* (Cat. 489).

Of cooking ware or plain ware storage pots, little can be said. The word 'pignatta' seems to have been generally used for cooking and storage pots in the olla-form, but some-

⁴⁶ Interestingly, low plate-like vessels with short rims were evidently not identified as such in the *PAH*: a glass 'tazza' (Cat. 332), found and identified in the present research in the MANN deposits, turned out to be a plate, and the terra sigillata 'coppa' also appears to be a plate fragment (II.3.1, Cat. 364).

times certainly of thin-walled mugs, and larger bronze kettles as well. One ambivalent ‘pignatta’ 24.3 cm high (Cat. 336) and a ‘vasettino’ 13.5 cm high (Cat. 340) were found in R19/20 together with three lids, ‘coverchiole’ (Cat. 337–339). Consequently, terracotta lids, ‘coverchiole di pignatto’, most probably refer to whole plain or cooking ware ollae. Besides these three, another four lids were found in the house (Cat. 205, 402, 499–500), one from the kitchen, one from cubiculum R31, and two from unknown locations.

Among vessels used for the domestic conservation of food-stuffs, an interesting assemblage is formed by a group of at least two transport amphorae and three *urcei* of garum, that appear in the report of Falkener with a detailed description. They belong to the group of finds, including the two plates above mentioned with olives, in the upper triclinium R25. Of the two large transport amphorae, quite exceptionally a drawing depicting their shapes was published by Falkener (Fig. 36). One amphora (Cat. 346) was for wine, and it had two *tituli*. It is visible also in an aquarelle painted by Falkener (see front cover in this volume). Its text in Latin has been deciphered by Minervini as *Kor(kyranum) opt(imum)*, best quality wine from Corfu. However, the reading *korinthia*, referring to Corinthian wine instead, should be more plausible. The other is an amphora for Iberian garum from Baetica, of the form Beltràn IIB (Cat. 347).⁴⁷ Three *urcei* for garum (Cat. 343–345) from the upper triclinium R25, not drawn by Falkener, must have been of the common one-handled type Schöne-Mau VI. *Inventario San Giorgio* reports the arrival of the three *urcei* at the MANN, one of them missing the handle, and the inscription on the third being very faint. Although their modern inventory numbers have been identified (inv. 17051–17053), the three vases could not be found in the MANN deposits. The first two inscriptions, *liquamen optimum*, referring to high quality garum, are not problematic. The third, in addition to *liquamen optimum*, also had a longer, fragmentary *titulus*, read by Falkener as *TVSCOLA ON OFFICINA SCAV*. This reading is taken up also by Minervini and *CIL* IV 2625. Considering that the *titulus* was fragmentary on both sides, and the reading insecure, I suggest to correct the text as *G(ari) f(los) scombri | o[ptimum?] | [ex] officina Scau[ri]*, referring to the products of the famous Pompeian producer A. Umbricius Scaurus (Fig. 37).

According to Falkener, two further transport amphorae came from an upstairs room above cubiculum R7 (Cat. 137–138); one of them had the inscription *MES | AM. XVII* (*CIL* IV 2603).

Other forms in terracotta were also listed: for example, a one handled *lagoenae*, ollae without handles, but complete with a lid. An enigmatic object is a handle of patera, listed under terracotta objects (Cat. 21). The *iter* of this object can be followed up to the *Inventario San Giorgio* in the MANN, in the volume containing the terracotta pieces, described as as ‘manico di patera con testa di pantera lungo circa once quattro’. This should confirm that the handle did not belong to a bronze patera H, but was indeed a rare terracotta imitation of such a vase.

⁴⁷ For further discussion, see Cat. 346.

Catalogue

II.3.1 Terra sigillata plate (Figs. 38–39, Cat. 364)

MANN 16654 (San Giorgio 5258).

Place of discovery: Upper atrium R29 (August 20, 1847).

Dimensions: Pres. H 2.4; D foot 8.0.

Technique: Four finger-prints are visible along the exterior of the base, as dipping marks.

Fabric: Fine-grained clay with no visible inclusions, pinkish light red. The slip is dark red, opaque, at places slightly transparent.

Condition: Of the plate, only the base and the central part of the floor of the bowl is preserved. On the exterior of the foot, one larger missing flake. Under the foot, the red colour has partly worn off from scratching.

Bibliography: See Cat. 364.

Description: A plate with a flat, horizontal well, on a high, conical foot. The exterior profile of the foot is carinated. On the interior, at the centre, a stamp in *plantapedis* form with the retrograde text *FORTV*, with the three last letters in ligature. Around the stamp, two concentric incised lines.

Comments: CF base type B2.7, belonging to Tiberian–Flavian plate forms 4.6; 6: 12: 18–21. The stamp is similar to *FORTV*, to left, Oxè – Comfort – Kendrick 2000, 846, 6 (*Fortunatus* or *Fortunati*). An earlier inventory number, 582 or 682, is written on the object with pencil. Middle of the first century AD.

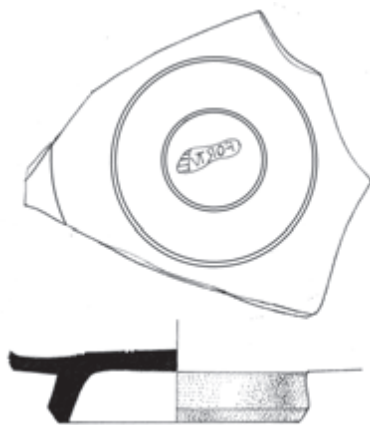

Fig. 38.



Fig. 39.

III INSTRUMENTS AND UTENSILS

RIA BERG

III.1 Lighting

According to the extant documentation, 19 objects that functioned to provide lighting were found in the 1847 excavation of the House of Marcus Lucretius. Of these, 12 were lamps, nine in terracotta (Cat. 20, 206–208, 284, 335, 401, 442, 492), three in bronze.¹ Of the terracotta lamps, only one has been described as decorated, with a figure of horse in relief (Cat. 211); ten have been described as monolychna, and two as bilychna (Cat. 206, 442). Three lamps are in bronze, one with the handle in form of a goose head (Cat. 427), one with a cock head (Cat. 258), and one suspended on chains (Cat. 319). Of these, only one terracotta lamp and the latter two bronze lamps have been located in the MANN, and are catalogued below.

In addition, one well preserved lantern, complete with all its functional parts, was found in cubiculum R6 (III.1.1, Cat. 131). The talcum plates found in the same room (Cat. 130) were connected to the lantern by Falkener, serving as its screens, but this does not seem probable, as their weight, almost 10 kg, is far too heavy. It seems more likely that what we have here is evidence for the use of these transparent mineral plates as window glass. Falkener mentions another lantern in R4, but this can be dismissed as an error (see discussion for R4 in Appendix 1). Additionally, a lantern wick, ‘stoppino di lanterna’, is mentioned among the finds from the servile quarters (Cat. 172), but such an item surviving as a separate organic find seems hardly possible. Minervini mentions that the lantern itself was complete with its wick; the confusion may arise from this object perhaps being either a lantern snuffler, used to extinguish the flame, or the bronze cylinder to hold the wick, found detached.

Whereas these twelve lamps and the lantern were surely all individual, functional utensils providing light in the house, the rest of the items – the six elements of candelabra, and the ‘lantern wick’ – are more complicated to categorize as functional units. Only one candelabrum, found in cubiculum R5 (Cat. 96), can be univocally identified as a whole object. However, there is much confusion in the documentation of this piece. In the *PAH*, it is described simply as resting on three feet, and terminating in a detached plate. This same description can be traced through the *Inventario San Giorgio* and the *Inventario Fiorelli*, but Falkener and Minervini, instead, speak of it as terminating in a Ionic capital and having a hook for suspending the lamp on top, a stem of iron, and four feet. Such a

¹ Minervini 1854, 21, however, cites a total of six monolychna terracotta lamps found in the House of Marcus Lucretius, and is the only author who mentions an iron lamp found in the house (*ibid.* 20).

piece is, actually, also present in the *Inventario San Giorgio*, listed together with finds from House IX, 3, 2. As Falkener also briefly mentions a candelabrum ‘with capital’ found in this house, the most probable conclusion is that the description of this spectacular piece has erroneously been attributed by Falkener and Minervini to the item found in R5. Another problematic piece is a candelabrum that solely according to Falkener was found in R7 (Cat. 134), but is not mentioned at all by the *PAH* – although no other finds from this room were mentioned either. Neither does it appear in a recognizable form in the *Registro Immissioni* or *Inventario San Giorgio*, and thus its existence remains dubious, to the point that it has not been counted among the finds here. The rest of the items related to candelabra are all small fragments: a foot (Cat. 10), a base of foot (Cat. 11), a plate (Cat. 164), and a top plate (Cat. 412). They could well belong to one dismembered candelabrum, the pieces of which were for some reason spread throughout R2, R11–14, and R32. Such a far-flung dismemberment could hardly be explained by damage during the eruption, and should be earlier. The presence of at least two candelabra can, however, be ascertained among the possessions of the house, although only one was evidently functional at the moment of the eruption.

The probable total number of functioning lighting implements in the house is thus 14: that is, 12 lamps, one candelabrum, and one lantern. As the candelabra function as stands for lamps, probably the bronze ones, they might have been paired with the two lamps with handles in the form of a bird’s head. The third bronze lamp was suspended by chains. The lantern, in contrast, would have been mostly used outside of the house.

As for the sheer quantity of lamps, 12, the number can be readily compared with other Pompeian atrium houses of roughly similar dimensions (Table 1). The larger double atrium house of Julius Polybius had the highest number of terracotta lamps, totalling 67, and one bronze lamp and three candelabra were also found in the house. In the large House of Menander there were 45 lamps.² In the House of Helvius Severus, 11 lamps come to the light.³ In Berry’s study of three insulae in Region I, of the 45 houses studied 27 contained terracotta lamps, for a total of 432, or on average 16 per house.⁴ In addition, there were 18 bronze lamps, 15 candelabra, 12 iron lamps, and 3 lanterns.⁵

The House of Marcus Lucretius totals were relatively low for the number of terracotta lamps. This might be partly due to the early excavation date, as these items may not have been saved. However, the total of 3 bronze lamps is plausibly a more efficient indicator of wealth, as stated by Marisa Conticello De Spagnolis and Ernesto De Carolis.⁶ The number of bronze lamps, in fact, is consistently quite low, with only 1–3 items even in large and wealthy houses. The three bronze lamps of the House of Marcus Lucretius, equalling the

² De Carolis 2003 a, 132-133; Allison 2006, 391.

³ Gallo 1994, 97.

⁴ Berry 1997a, 102.

⁵ Berry 1997a, 104.

⁶ Conticello De Spagnolis – De Carolis 1988, 17. In contrast, the small number of iron lamps found in Pompeii has made De Carolis (2004, 73-74) conclude that they were produced only occasionally, probably locally, as modest artefacts.

Casa di M. Lucretius	Casa di Treb. Valens	Casa del Menandro	Casa di I. Polybius	Casa degli Amanti	Casa di M. L. Fronto	Casa dei Quadretti teatrali	Casa del Sacello Iliaco
555 m ²	500 m ²	1800 m ²	700 m ²	460 m ²	570 m ²	575 m ²	500 m ²
12 (9–3)	2 (1–1)	45 (42–3)	68 (67–1)	10 (9–1)	8 (7–1)	3 (2–1)	6 (4–1–1)

Table 1. The quantities of lamps in Pompeian atrium houses, total (terracotta–bronze). Recorded in the database of Penelope Allison Pompeian Households: An On-line Companion, <http://www.stoa.org/projects/ph/home>.

number from the rich House of the Menander, are thus a significant status marker. The lantern is also a relatively rare and prestigious item.

As for the find spots of the lamps, in the House of Julius Polybius the distribution of the 67 lamps was relatively even, with major concentrations in the larger rooms, as described by Nella Castiglione Morelli del Franco.⁷ In the House of the Menander they were concentrated in rooms 1 and 4 near the atrium, and 11 and 22 around the peristyle. Penelope Allison has estimated that of the 94 lamps found in the Insula of the Menander, some 37 may have been in places of use, with the rest in storage.⁸ For the whole insula of the Menander, Allison notes that less than one lamp per room has been recorded, and therefore the illumination must have been generally low.⁹

In the House of Marcus Lucretius the number of lamps (12) is also much lower than the number of rooms (32), not considering the rooms upstairs. The proveniences of the lighting implements, however, point to their rather even distribution about the house. As they are notably absent, except for the lantern, in the main storage areas, and cubacula R4 (3), R5, or R6, several of them may be in their places of use. The major cluster of terracotta lamps is the group of three found in the servile quarters, and could suggest either their storage there, or work being done in this area later in the day. Of the other five lamps, one was found in the atrium R2, three in the garden R18 or its surroundings, one in R19/20, one in cubiculum R31, and two in undefined places in the posterior part of the house. The three bronze lamps were all found in or nearby the garden area: one in the central garden area (Cat. 258), one in its upper layers and possibly fallen from the first floor (Cat. 319), one in the adjacent corridor R34 (Cat. 427). This could be further proof for the placement of prestigious living quarters above the garden. The lamp found in the small cubiculum R30 (Cat. 401), with some toiletry items, could most plausibly be in a context of use. Most of the cubacula, were, however, found without evidence of a means for lighting. The candelabrum was kept in storage or was in use in cubiculum R5, near the triclinium area, together with the medical instrumentarium. The general distribution map of lamps in the

⁷ Castiglione Morelli 1983, 249–250.

⁸ Allison 2006, 391.

⁹ For the lamp distribution in the Insula of Menander, Allison 2006, 390–392; for the distribution in other houses, Allison, *Pompeian Households: An On-line Companion*, <http://www.stoa.org/projects/ph/home>.

House of Marcus Lucretius is in line with the results of Caputo and Tamburrelli,¹⁰ who have examined the proveniences of the terracotta lamps in the MANN collection: they were most often found in cubicula, secondly in atria, and lastly in gardens and servile areas.

Catalogue

III.1.1 Bronze lantern (Figs. 1–3, Cat. 131)

MANN 72070–7207 (San Giorgio 48291–8295).

Place of discovery: Cubiculum R6 (March 24, 1847).

Dimensions: H suspended with chains 55.2; H of the lantern 18.0; D 15.0.

Condition: The objects is preserved intact, except for a small piece missing from the lower cylinder band. The surface is corroded with greenish patina.

Bibliography: Dwyer, 26 iii, fig. 10; Berg 2008a, 123, fig. 8.10; Berg *et al.* 2008, 207. See also Cat. 131.

Description: The base is formed by a metal disc with raised borders. It stands on three feet, each composed of a spherical element, below, and a cylindrical element, decorated with incised lines, above. The circular, raised border of the base disc is connected to another circular band, above, by two vertical bronze bars. The vertical bars have a rectangular section at the base, and above, a faceted section; at the top, they have an elaborately moulded profile, and two holes, one decora-



Fig. 1 (left). Fig. 2 (right). Niccolini 1854, pl. IV, 10.

¹⁰ Caputo – Tamburrelli 2007, 78.

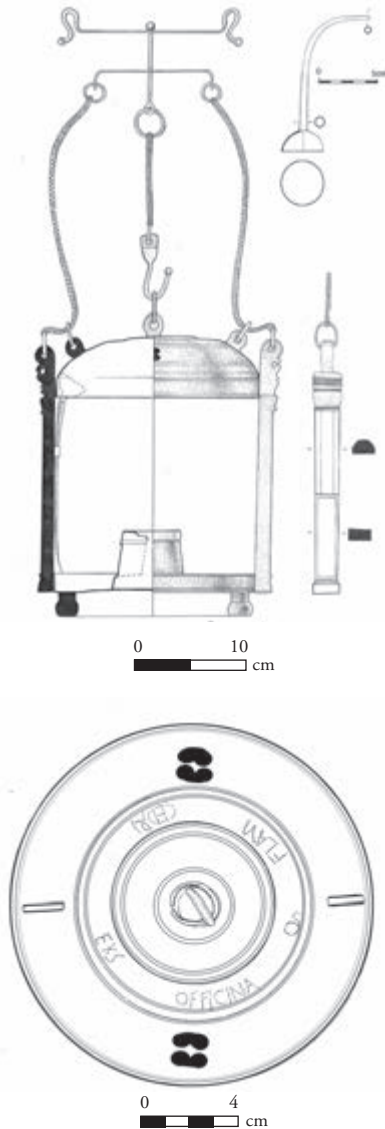

Fig. 3.

tern has been found in the Villa of Boscoreale, *torcularium* Y, now in the collection of the *Römisches Antikenmuseum Berlin* (inv. Misc 8854), Oettel 1991, 52, cat. 36, pl. 31 a–b, with bibliography. It is an exact parallel to the present lantern, even down to the smallest decorative details. A very similar example has also been found in the House of the Menander, among a group of victims of the eruption (inv. P4773), Stefani 2003, 365, cat. IV.361; De Carolis 2003 b, 141, cat. B32. A similar lan-

tive, and one for the chain to suspend the lantern. The chains are attached, above, to a handle made of two horizontal bars and a vertical element. On top of the upper cylinder rests the hemispherical, movable cover. To the sides of this top cover, two rings are attached, from which part hang the chains that serve to suspend the cover, when opening the lantern, to a hook in the horizontal handle above. On the rounded top of the lantern there is an inscription, *EX OFFICINA Q. FLAVI CEDRI*, and it is also decorated with a series of concentric, incised lines. It also has two holes in the form of figure 8. The cylinder for the lamp wick was positioned at the centre of the bottom disc. It is a slightly conical cylinder, decorated with incised lines, with a removable cover, inside of which there is a smaller cylinder; the first is for fuel, and the second for the wick. The translucent sides of the lantern may have been fashioned of thin slices of horn, parchment, or animal bladder. These may have been inserted on the interior of the lower cylinder, where there is another parallel metal band, and also vertical bars flanked on the inside by another plate; the translucent material would have been inserted in between these elements. The snuffler is composed of a long narrowing cylinder attached to a hemispherical bronze bowl.

Comments: Minervini (in Niccolini 1854, 20) not only published a drawing of the object, but also described it at some length. He mentioned, in particular, that the wick (*lucignolo*) of the lantern was still partially preserved, although carbonized, and presumes it was made of hemp (*canapa*). The lantern was accompanied by a snuffler (*spegnitoio*), that can be seen also in Niccolini's drawing (1854, pl. IV, 10), beside the lantern; it has the form of an upturned strainer with a curved stem.

The object is quite probably the same one that Falkener mentions among the finds from R6: 49 'lantern, with talc lights'; 51, n. An identical lan-

tern comes from house I 14, 12, room 2, De Carolis 1999, 260, cat. 332 (inv. P43468). A slightly less elaborate but still similar lantern was found in the House of M. Lucretius Fronto, room *n* (inv. P2174/1900), Moormann 1993, 395–396, fig. 265. Yet another example, slightly different in the mouldings, was found at a crossroads of the Via dell'Abbondanza, see *Rediscovering* 1990, 184–185, cat. 80. A similar lantern in the MANN collection (inv. 72078) was published in Pirzio Biroli Stefanelli 1990, 276, cat. 79, fig. 185; *Collezioni Napoli* 1986, 182, cat. 65. For Roman lanterns in general, Boube Piccot 1975, 54–58, with bibliography; Pirzio Biroli Stefanelli 1990, 93–94.

III.1.2 Terracotta lamp (Figs. 4–5, Cat. 207)

MANN 19904 (San Giorgio 5221).

Place of discovery: Kitchen area R11–14 (August 13, 1847).

Dimensions: H body 2.6; H (pres. with handle 4.3); D disc 5.6; L 9.3; W nozzle 3.5; D base 3.3.

Technique: There are numerous fingerprints resulting from dipping the lamp into the slip.

Condition: The lamp is preserved intact except for the handle, of which only the lower half remains.

Bibliography: See Cat. 207.

Fabric: The clay is compact, without visible inclusions, and light beige in colour.

Description: A lamp with a single, wide triangular nozzle with relief volutes at sides. A vertical ring-handle, decorated with two incised lines. On the disc, outlined with a groove and a ridge, a quadruped in relief, described in earlier inventories as a horse, but possibly a deer (short tail, bifid hooves), running to right. The filling hole is in between the legs of the animal. The whole surface is covered by an uneven coating of dark reddish-brown lustrous slip, with slight metallic reflections.

Comments: Loeschke type 1c; Bisi Ingrassia 1977, type VIB. Flavian date.

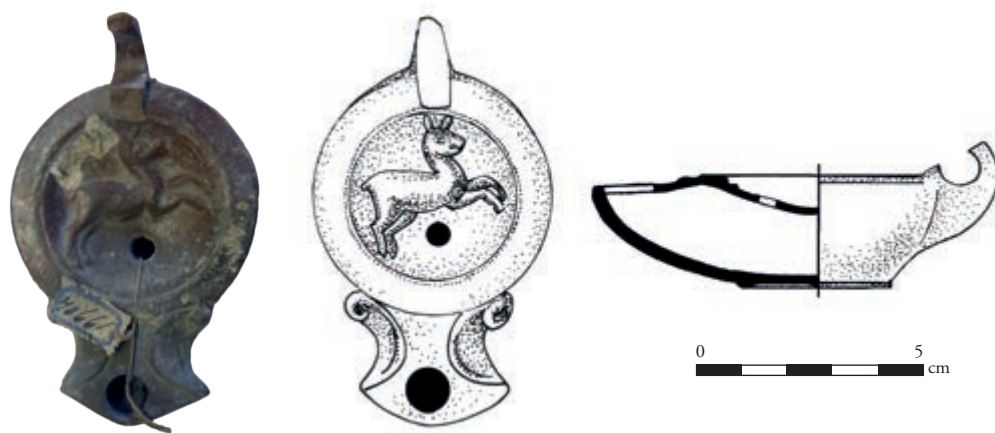

Figs. 4–5.

III.1.3 Bronze lamp (Figs. 6–7, Cat. 319)

MANN 722118 (San Giorgio 8343).

Place of discovery: Near the garden R18 (June 9, 1847).

Dimensions: H body 2.5; H with reflector 4.4; W 5.3; L 10.1; W nozzle 2.3; D base 3.0.



Fig. 6.

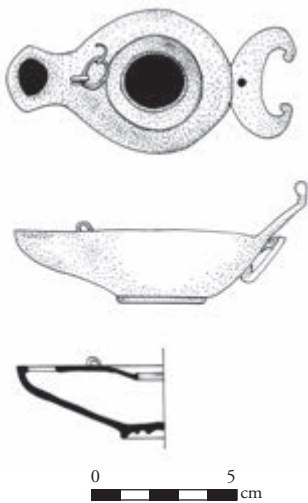

Fig. 7.

Condition: The lamp is preserved intact. The whole surface is covered by a green patina, lighter in the lower parts of the body; the surface is raised at some points. The chain for suspension has broken off, and only the first whole ring and two broken ones are preserved. The circular ends of the crescent shaped reflector are bent.

Bibliography: Valenza Mele 1981, 127–128, Cat. 308, fig. 308–308 a. See also Cat. 319.

Description: The nozzle is not distinct from the body. Reflector in the form of a crescent, with two circular endings, offset with incised lines. At the base of the reflector, a perforated hole. Low ring foot, disc slightly concave, without border. At the join the of the nozzle and body a small vertical loop for the suspension of a chain is attached, matched by a ring handle as another loop. Of the chain, only a very small fragment is preserved. The alimentation hole is provided with a cavity at the border, for the insertion of a tap. Very low ring foot, below the base, of two raised concentric rings.

Comments: The lamp was published by Valenza Mele (without provenience), who identifies this type as a simplified form of Loeschke XXI. Conticello de Spagnolis – De Carolis 1988, 195 discuss this type in the Pompeii and Herculaneum store-rooms: A very close parallel is cat. 127 (cat. P484), 196, fig. 197, from Casa dei Cervi in Herculaneum. Date 1st century AD.

III.1.4 Bronze lamp (Figs. 8–9, Cat. 258)

MANN 72295 (San Giorgio 8324).

Place of discovery: Garden R18 (May 12, 1847).

Dimensions: H body 2.7; H with handle 8.1; L 11.5;

Condition: Preserved intact, handle deformed. On the surface, green patina and corrosion.

Bibliography: Dwyer, 52, i, fig. 56; Valenza Mele 1981, 96, cat. 210, fig. 210–210a; Berg 2008a, 121, fig. 8.8; Berg et al. 2008, 207. See also Cat. 258.

Description: Lamp with pear-shaped body. The shoulder is formed by a horizontal band that circumscribes the whole lamp. The disc is joined to the hole of the nozzle by a channel. The nozzle is narrowed at the join with the body, and ends in a half-circular form. At the centre of the disc, there is a drop-shaped filling hole. The handle is high and curving, and ends in the head of a cock with crest. The head of the cock is offset by a raised ring, and its beak is perforated by a small circular hole. Flat base.



Fig. 8.



Fig. 9.

Comments: The general type is Loeschke XX/Valenza III, one of the most common basic lamp types in the 1st century AD, with 79 examples in the MANN, 23 from Pompeii, and 15 from Herculaneum. For the type, most commonly provided with a goose/swan head handle, see Conticello de Spagnolis – De Carolis 1988, 137–139. At least two similar lamps with heads of a cock are preserved in the MANN, inv. 72293 and 72294, Valenza Mele 1981, cat. 211–212. Datable to the third quarter of the 1st century CE. Conticello de Spagnolis – De Carolis 1988, 144, present two examples of similar ‘pear-shaped’ lamps with a handle ending in the head of a cock, cat. 103, fig. 167 (inv. P3808) from Pompeii I VII, 11 and cat. 104, fig. 168 (inv. E1528) from the palaestra of Herculaneum.

III.2 Medical and Cosmetic Instruments

A remarkable medical assemblage was found in cubiculum R5 of the House of Marcus Lucretius. Nineteen instruments can be attributed to it with certainty, and a bleeding cup discovered in the garden area can also be reasonably included, for a total of 20 objects. On the basis of this evidence, the House of Marcus Lucretius has been included in the list of doctor’s houses in Pompeii, in which Hans Eschebach included 19 and Lawrence J. Bliquez 25 habitations.¹¹ The collection of medical instruments in the house was noted already at the moment of its discovery: Falkener and Minervini discuss it at length in their

¹¹ For the distribution of medical instruments and practices at Pompeii, see Eschebach 1984, 4–5, fig. 2; Bliquez 1994, 78–98; Künzl 1999, 578–591. For the medical context of the House of Marcus Lucretius, Eschebach 1984, 50–53; Bliquez 1994, 82–83. Künzl 2002, 59, fig. 78, too, summarizes 25 doctor’s houses at Pompeii, including the House of Marcus Lucretius, for which in part., p. 61.

texts.¹² Additional, albeit more generic medical and toiletry objects found in other rooms of the house totalled 26: 17 unguentaria, 5 probes, a *pyxis*, a tweezer, and two mirrors.

Amongst the most highly specialized tools in the medical assemblage were five surgical scalpels (Cat. 101). In the *PAH* they have simply been called five ‘tasti da cirusico’, an expression normally referring to probes,¹³ but the *Inventario San Giorgio*¹⁴ specifies that three had a bronze handle and iron blade (length ca. 12–14 cm) and must have been surgical scalpels; the other three consisted only of a handle (L ca. 10 cm). Minervini observed that their form corresponded to those illustrated in Vulpes (1847), pl. VII, confirming the identification as scalpels (Fig. 10).¹⁵ Two handles have been located in the MANN (III.2.1, III.2.2).

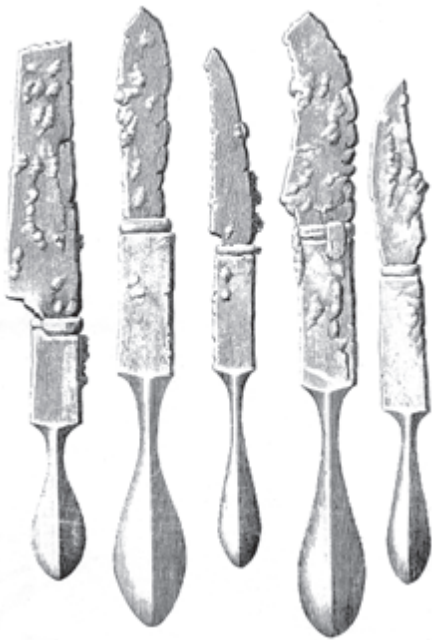

Fig. 10. Scalpels illustrated in Vulpes 1847, pl. VII.

Two sharp hooks, *hamuli acuti*, useful in treating wounds and cuts, were also recovered (Cat. 107–108), and one of them has been located in the MANN (III.2.3). Among the other instruments, there were two tweezers (Cat. 99–100), of which we have only the description of Minervini, who mentions that they both had in-turned, dented jaws, and were thus quite specialized medical instruments.¹⁶ There were also seven cylindrical bronze containers for instruments and medical substances (Cat. 109–114), including a rare silvered one (Cat. 123); two of these have been located in the MANN (III.2.3, III.2.4). One of the cylinders was described as containing a plaster or bandage (‘cerotto balsamico’) at the moment of discovery, and another as containing an unspecified number of probes made of iron (Fig. 12). Minervini calls these iron instruments *specilla*, and comments that two of the bronze cylinders were large and four small. Their dimensions were specified in the *Inventario Fiorelli*: The largest is 18.7 cm, the others between 8.8 to 9.7 cm; the iron probes contained in one of them, 16.5–17.6

¹² Falkener 1852, 52–53; Minervini 1954, 20.

¹³ For medical probes in general, Krug 1993, 93–96.

¹⁴ Inv. SG 8310–8314 (bronzi minuti).

¹⁵ Minervini 1854, 20: “alcuni scalpelli”; Vulpes 1847.

¹⁶ Minervini 1854, 20. Even though Falkener defines them as ‘small forceps’, this would refer rather to pincers than tweezers. *Inv. San Giorgio* 8308–8309 gives their lengths as ca. 12 and 14 cm, which would mean that they were larger than normal cosmetic-medical tweezers. The tweezer with denting is Riha 1986, type A. For the types and uses of tweezers and forceps in medicine, see Jackson 2003, 316; Krug 1993, 88–89.

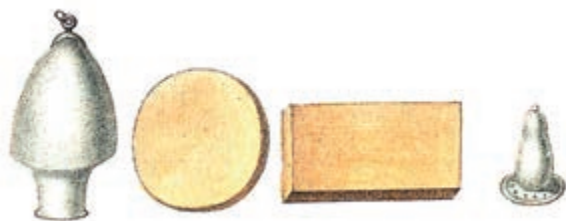

Fig. 11. Medical instruments from the House of Marcus Lucretius, except for the rounded disc: bleeding cup, *coticula*, cannula, Ceci 1858, pl. XII, 29, 31, 32.

could be a medical cannula (III.2.4, Cat. 115). Furthermore, a bleeding cup, recognized as such by Bliquez, was found in the garden area (III.2.6, Cat. 309). The *atramentarium* (Cat. 119) found in the room might also be read as part of this context.

A bleeding cup, a *coticula* slab coloured either green or brown in various editions, and the cannula spout are shown together in an illustration of Carlo Ceci (1858, pl. XII, 29, 31, 32), and are quite probably the items found in the House of Marcus Lucretius (Fig. 11).

In his table, also a tubular container with a tweezer, a probe and a hook is shown (pl. XII, 23); this might be the container with a selection of instruments found in the House of Marcus Lucretius (Fig. 12).

The most closely comparable Pompeian medical instrumentaria, for their size and typology of objects, are the contents of two *thecae vulnerariae*. One, a wooden box, was found in the Palestra Grande, beneath a fallen victim of the eruption, identified as a doctor. It contained 23 instruments: four surgical knives, six cylindrical containers, two tweezers, two sharp hooks, six probes of different forms, a needle and a needle handle, and a slate stone slab, *coticula*.¹⁷ Another similar wooden medical box of rectangular form (17 x 8 cm), divided into compartments, containing 20 instruments, was found in Herculaneum *fornix* 12, amongst the remains of victims, containing a *coticula* slab, seven bronze cylinders, six bronze knife handles, a tweezer, two sharp hooks, a probe, a cataract needle, and other iron instruments.¹⁸

Larger medical contexts in the Roman Empire have been examined and by Ralph Jackson, comparing them by the quantities and types of in-



Fig. 12. A medical container, Ceci 1858, pl. XII, 23.

¹⁷ *NSc* 1939, 220; Bliquez 1994, 87–88; Künzl 2002, 60; De Carolis 2003 b, 378, 381–382.

¹⁸ De Carolis 2003 b, 135–136.

struments contained. On average, 30–40 instruments were found in the larger Pompeian doctor's houses, such as the Casa del Medico nuovo, and in the larger medical funerary contexts in various parts of the Empire.¹⁹ As the total of 21 instruments from the House of Marcus Lucretius is closer to the portable *theca vulneraria* ensembles than these, both in the number and the typology of the objects, this leads us to putatively identify the context of the house as a similar, basic professional and multifunctional portable medical box. Ernst Künzl defines the House of Marcus Lucretius, together with the Casa del Fabbro (I 10, 7), Casa di Apollo (VI 7, 23), and Casa del Centauro (VI 9, 3.5), as a *domus* self-sufficient in medical matters.²⁰ However, the House of Marcus Lucretius assemblage, also including numerous instruments for surgical operations, seems to suggest that a professional doctor operated in or from the house, rather than someone who treated only its inhabitants.

To be remembered, in this connection, is the central image of the centaur Chiron in cubiculum R4, an inventor and teacher of the medical arts, possibly particularly venerated in the house. Furthermore, Eschebach has proposed that a doctor worked in the taberna IX, 3, 6 on the right side of the entrance of the house, where a cylindrical bronze container, 22 unguent bottles and a bronze seal with the name *PHOSPHOR* were found.²¹

Many of the other scattered medical-pharmaceutical objects from the house may have been functional in toiletry uses rather than medicine, such as the tweezer from the ala R8 (III.2.7, Cat. 144). A fragment of a bone spatula (Cat. 8) and a glass unguent bottle, 'lachrimatoio', probably drop-shaped Scatozza 47, (Cat. 16) were also found in the atrium area.

A small array of six toiletry items were found together in cubiculum R32, suggesting that this was a functional set, and possibly also a space used for grooming activities, as has been discussed on p. 64 in connection with gender-bounded activities. These included a rectangular bronze mirror (Cat. 411), four bronze probes (Cat. 416–419), and a pyxis-like bronze container with sulphur (Cat. 410). A second concentration of toilettries was found in the kitchen area, probably in R11: another mirror in the form of a bronze disc (III.2.9, Cat. 166), and three small glass unguent bottles (Cat. 176–178). The above mentioned three groups of objects may be functional use contexts.

The two groups of unguent bottles in storage contexts have been discussed in the chapter on glass vessels.²²

Besides, in R3/4, the principal storage area of the house, a bone knife handle (Cat. 78) and a scales (Cat. 124) were found in cubiculum R6; these may have been functional

¹⁹ Jackson 1995, 196–197, table 1; for the ancient definitions of a basic medical kit, 193–194; Künzl 1999, 578.

²⁰ Künzl 1999, 587, 589.

²¹ *PAH* II, 454; Eschebach 1984, 53.

²² See p. 150. In the secondary atrium R19, six glass unguentaria (Cat. 365, 392–395), called 'caraffinette', were kept in a cupboard recess. Five glass bottles, also called 'caraffinette', were found in R3/4 (Cat. 85–88), or, as one of them is defined as 'piccolissima' (Cat. 89), any form of small unguentaria. As occasional finds, R19–20 produced one more 'bocchetta a palla' ca 10 cm H (Cat. 331), as did the upper triclinium R25 (Cat. 348).

in preparing medicine. A nearly complete, although broken, set of bronze scales was found in R6 (Cat. 124), and is the only example considered in the catalogue. According to the *PAH* this instrument was fragmented, consisting only of the beam and the cup. Falkener, instead, reports scales from both R4 and R6, and describes the latter as including a beam and a weight in the form of the head of Mercury, and thus having a commercial iconographical reference. Minervini, as well, speaks of two scales found in the house, one with beam and cup, and another with beam and weight. He is the only author to mention an iron weight.²³ Another beam from a bronze set of scales was found in the upper layers of the garden area (Cat. 291), and two small bronze weights were reportedly found in the servile quarters R11–14 (Cat. 158, 161). Weighing equipment can serve various uses in a household, depending on their accuracy. Larger stone weights for weighing heavier bulk substances were also present in the house: two of them are mentioned in the *PAH* (Cat. 183, 479). One of the stone weights was found in the servile quarters, while the other is without clear reference to a find spot.

In the end, in the R4/3 storage area pieces of blue colour, defined ‘belletti’ in the *PAH*, possibly for cosmetic use, were found (Cat. 95) as well as a horn (Cat. 79), that might have been kept as amulet, or also raw material to produce, burnt, medical, magic or cosmetic preparations.

Catalogue

III.2.1 Scalpel handle (Figs. 13–14, Cat. 101–106)

MANN 77675 (San Giorgio 8310–8314).

Place of discovery: Cubiculum R5 (April 15, 1847).

Dimensions: L 10.0; Th. 1.1.

Condition: Only the handle is extant, covered with green patina.

Bibliography: Bliquez 1994, 114, Cat. 20, fig. 12. See also Cat. 101–106.

Description: The central part of the handle is square in section. The handle ends in a flat spatula or blunt dissector in the shape of an elongated leaf, divided vertically in two halves by a central ridge. The missing blade was held in place at the other end of the handle in a thin opening between two elements ending in volutes.

Comments: For the use of scalpels in chirurgical operations, and their typology, see Jackson 2003, 314–316, fig. 1, 1–3; Krug 1993, 79–83. Jackson illustrates a selection of similar scalpels, of standardized forms, in 1990, 14, fig. 1, 6–12. See also a recently found example from *Insula* VI.1 excavations, Cool 2016, 90, cat. 28, fig. 4.7. This item belongs to the most common scalpel-dissector type, with 58 examples in the MANN and 18 in the Pompeii collections, Jackson 1994,

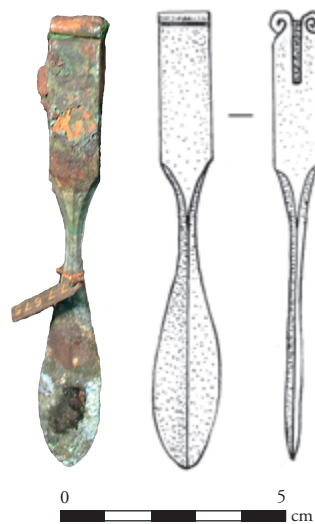

Figs. 13–14.

²³ Minervini 1854, 20; 1855, 83.

207–211. The whole instrumentarium is datable to the 1st century AD.

III.2.2 Scalpel handle (Figs. 6–7, Cat. 101–106)

MANN 77679 (San Giorgio 8310–8314).

Place of discovery: Cubiculum R5 (April 15, 1847).

Dimensions: L 10.1; Th. 1.2.

Condition: Only the handle is extant, strongly corroded with a dark green patina, with some orange spots. There is nothing left of the iron blade except for some iron debris inside and around its socket. *Bibliography:* Bliquez 1994, 115, Cat. 26, fig. 13; Berg *et al.* 2008, 124, fig. 8.11; 207.

Description: See above.

Comments: See above.

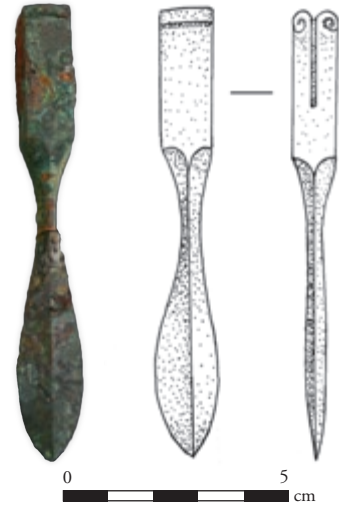

Figs. 15–16.

III.2.3 Bronze instrument with sharp hook (Figs. 17–18, Cat. 107)

MANN 78052 (San Giorgio 8315–8316).

Place of discovery: Cubiculum R5 (April 15, 1847).

Dimensions: L 14.9.

Condition: Preserved intact. All surfaces are covered by green, uneven patina.

Bibliography: Bliquez 1994, 127, cat. 74, fig. 37; Berg *et al.* 2008, 207.

Description: Thin rod with circular section; thinning towards the pointed and curved hook. There is a group of low moulded rings at ca. 2/3 of the length of the stem, which ends, as a handle, in a convex knob, with a projecting moulding at the point of its largest diameter.

Comments: According to the excavation documentation, two similar sharp hooks were originally found together. They were instruments used principally for retracting the margins of wounds, and incisions, but also in many other types of operations, see Krug 1993, 86; Jackson 2003, 317. Jackson 1990, fig. 15, 1–3 illustrates a selection of this type of instrument, called in antiquity *hamuli acuti*.



Figs. 17–18.

III.2.4 Bronze container (Figs. 19–20, Cat. 110)

MANN 78189 (San Giorgio 8317–8322).

Place of discovery: Cubiculum R5 (April 15, 1847).

Dimensions: H 8.6; D base 1.7; D mouth 1.5.

Condition: Integrally preserved, lid missing. The surface is better preserved in the upper, narrowed part, with a brownish colour and minimal corrosion. Other surfaces are covered by green, uneven patina.

Bibliography: Bliquez 1994, 127; Berg *et. al.* 2008, 207. See also Cat. 110.

Description: Cylindrical container. Upper end cut back to take a cylindrical lid 2.4 cm high, now missing. No decoration.

Comments: For numerous finds of such bronze cylinders in Pompeii, see Jackson 1994, 203; and, for example, the group from the Grande Palestra, De Carolis 2003 b, 382, cat. IV.495. A very similar item comes from the medical context of the Casa del Fabbro (I 10, 7, above room 7), L 8.5, D 2.2 (inv. P5389), see Allison 2006, 206, cat. 1512, fig. 51.5, pl. 96.8.

III.2.5 Bronze container (Figs. 21–22, Cat. 109)

MANN 78188 (San Giorgio 8317–8322).

Place of discovery: Cubiculum R5 (April 15, 1847).

Dimensions: H 18.4; D 3.0. The container is 17.0 cm high without lid. H of lid 2.8.

Condition: Preserved intact, and complete with removable lid. All surfaces are covered with green patina. Only the stepped-in upper zone, for the insertion of the lid, has a conserved brown lustrous colour.

Bibliography: See Cat. 109.

Description: A large cylindrical container, upper end cut back to take a lid 1,6 cm high. The cylinder is decorated with seven groups of two rows of ridges, that divide it into zones of approximately 2 cm height. The lid is cylindrical, its top slightly concave and decorated with concentric circles. On the inside, the internal cavity does not extend through the whole capsule, but stops at the depth of 6.5 cm. Thus, the lower part of the cylinder must be an independent, larger capsule, ca 12 cm high. Its lower end, corroded to the degree that it cannot be removed, should thus be a second lid.

Comments: Similarly, a large cylindrical container, H 16 cm, has been found with five other, smaller cylinders in a medical box context in the Grande Palestra (II, 7) of Pompeii, see above, De Carolis 2003 b, 382, cat. IV.495–500.

III.2.6 Bronze cylinder (*cannula*) (Fig. 14–15, Cat. 115)

MANN 69796 (San Giorgio 8323).

Place of discovery: Cubiculum R5 (April 15, 1847).

Dimensions: H 7.5; D 3.0; D rim max 4.1.

Condition: Preserved intact, covered with a greenish patina on all surfaces. Minor breakages at the out-turned rim.

Bibliography: Eschebach 1994, 53; Berg *et al.* 2008, 207. See also Cat. 115.

Description: A cylindrical, hollow bronze object. One end closes

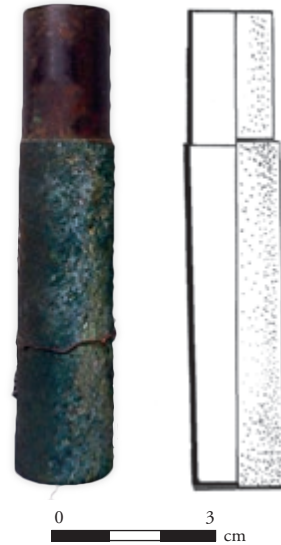

Figs. 19–20.

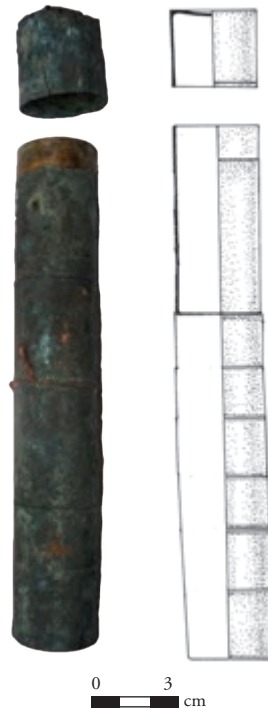

Figs. 21–22.

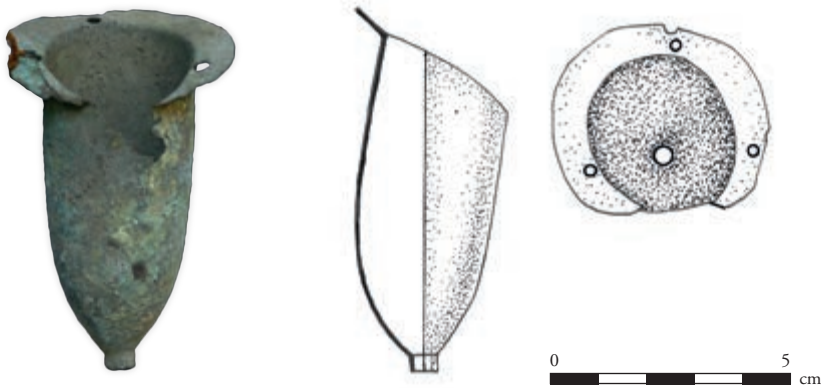

Figs. 23–24.

in a convex curve as a sort of funnel, the other has an oblique rim, with an out-turned flat rim on three sides. The rim is perforated by three small holes, probably to attach it.

Comments: The form of the objects led the excavators to compare it to a phallus. More consistent with the form, which is a sort of funnel or spout originally attached to another object, would be its identification as an orifice for water, i.e. part of a fountain. However, this also seems unlikely, as such objects (*fistulae*) were normally made of lead, and this object has no isolated seal to make it water-tight. According to Eschebach 1994, 53, the object might be a medical cannula, or drain tube. For Roman *cannulae*, as described by Celsus for draining ascites, and extant specimens with a smaller diameter, or other tubular instruments, *plumbae fistulae*, see Milne 1907, 148–150; Jackson 1990, fig. 6, 4. For bronze clysters of tubular shape, Jackson 1990, 19, fig. 6, 5–6.

III.2.7 Bronze tweezer (Figs. 25–26, Cat. 144)

MANN 77847 (San Giorgio 8328).

Place of discovery: Ala R8 (April 14).

Dimensions: L 8.5; W 0.6.

Condition: Completely preserved, except for one edge of the tip. Covered by a greenish patina.

Bibliography: See Cat. 144.

Description: A tweezer with stepped moulding at shoulder, a simple U-shaped hinge, jaws are turned in and narrowed at tip.

Comments: Riha 1986 type F, among the most common in Pompeii.

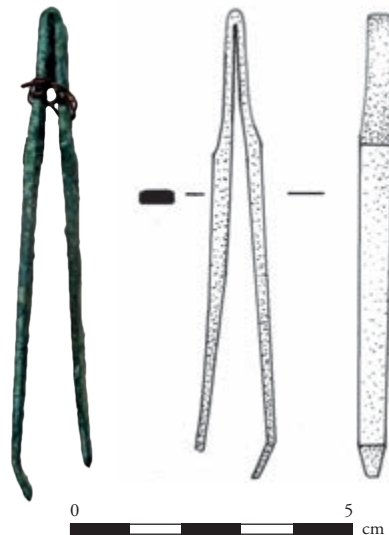

Figs. 25–26.

III.2.8 Bleeding cup (Figs. 27–28, Cat. 309)

MANN 77988

Place of discovery: Near to the garden R18 (June 9, 1847)

Dimensions: H 14.5; D rim (rec.) 4.4; D max. 9.2.

Condition: Broken at the rim and neck, of which only about one quarter is preserved. The whole surface is covered by a green patina, and it is much corroded and deformed in places.

Bibliography: Bliquez 1994, 112, cat. 13, fig. 10; Berg 2008a, 124, fig. 8.11; Berg *et al.* 2008, 207. See also Cat. 309.

Description: The vessel has rounded bottom, convex sides, and carinated shoulder; the neck is concave. Rim is vertical and plain.

Comments: Bliquez 1994 suggested that this object could come from the House



Figs. 27–28.



Figs. 29–30.

of Marcus Lucretius, and this can be confirmed by the present research. Originally the cup must have had a ring attached at its bottom (*PAH* II, 467, ‘avente nella parte inferiore un anello disaldato’). For these vessels, called *cucurbitae*, and their use, see Jackson 1990, 14, fig. 1, 1–3; Krug 1993, 96–97.

III.2.9 Bronze mirror (Figs. 29–30, Cat. 166)

MANN 74915 (San Giorgio 8530).

Place of discovery: Servile quarters R11–14 (August 12, 1847).

Dimensions: D 12.5; Th. 0.2.

Condition: Preserved intact, except some for minor breakages at the edge. The front side is covered with darker and lighter areas of green patina, with some blue spots. The back side has mostly preserved its metallic silvery sheen, with green encrustations and patina in some places. A darker spot at one edge may indicate the original attachment point of a handle.

Bibliography: See Cat. 166.

Description: Disc mirror, slightly convex on the reflecting side. The reflecting side is bordered by one incised line along the edge. On the backside, two lathe-turned lines around the centre (D 2.0 and 2.4), and along the edge (D 10.7 and 12.0).

Comments: The mirror can be attributed to the type B of Lloyd-Morgan 1991.

III.3 Iron Tools

A large group of iron tools, comprised of 14 objects, was found in the House of Marcus Lucretius. Of them, seven can be classified as agricultural tools, and one as a carpentry tool, a plane, the only one located in the MANN (III.3.1, Cat. 463). The remaining six are more versatile, less clearly described, and only generically identifiable as hardware tools.

The implements for agriculture or gardening include four tools identified in the *PAH* as ‘ronche’ or ‘roncigli’, translated by Falkener as ‘woodman’s bill’, and interpreted in Latin by Minervini (who mentions only two, as does Falkener) as *runcones*.²⁴ These belong to the class of implements of which Allison notes that the word ‘ronciglio’ is mostly used for tools with curved iron blades, which were probably either reaping hooks, billhooks, or pruning knives (Fig. 31).²⁵

Two such objects were found in the main storage room R3/4 (Cat. 83–84). Two other ‘ronche’, without a precise provenience, but found in the posterior part of the house, were recorded in the *Inv. San Giorgio* (Cat. 467–468) with lengths of 37 and 22 cm. Other Pompeian examples include, for example, one in the House of the Menander with a total length of 36.5 cm, with a narrow attachment for a wooden handle and a sharply curving blade.²⁶ These instruments were primarily for tending vineyards, and in the case of the 14 pruning knives found in the House of the Menander, it has been calculated, counting two instruments/person (doubled for reserve as Columella suggests), that the tools would suffice for seven workers, who may have worked a cultivated area of 50–150 *iugera* (ca 12–37 ha) just outside the city.²⁷ Estimating in the same way for the four pruning knives from the House of Marcus



Fig. 31. Pruning knives (‘ronche’, ‘roncigli’) from the insula of the Menander, Allison 2006, fig. 27–28.

²⁴ Minervini 1854, 20; 1855, 83–84. For the agricultural implements in Pompeii, Kolendo 1985; for the Insula of the Menander, Allison 2016, 397.

²⁵ Allison 2006, 27. The examples from the Insula of the Menander range from 20 to 44 cm in length.

²⁶ Pagano 2003, 199, cat. O1.

²⁷ Pagano 2003, 198; Kolendo 1985, 115.

Lucretius, a third of the area may have been cultivated (4 ha), but more if one does not count for the ‘professional’ doubling of reserve instruments, perhaps even 8 ha.

Two hoes (‘zappe’) are, likewise, probably agricultural tools with rectangular or trapezoidal wide iron blades attached to a long wooden handle, for breaking and turning over the ground (Cat. 464–465, Fig. 33).²⁸ Minervini calls the two hoes by their Latin name, *ligones*. According to the *Inventario San Giorgio*, the two iron hoes of the House of Marcus Lucretius measured 19 and 22 cm, respectively. Published parallels for such utensils include twelve from the House of the Menander (Fig. 32).²⁹

The ensemble of four pruning knives and two hoes is a relatively large set of agricultural utensils, hardly necessary for the very small garden area – filled with statues – of this house. The household would probably have owned cultivated land, including a vineyard, in or outside the town.

The small axe (Cat. 80), for Falkener a ‘hatchet’, an ‘acetta’ in the *PAH*, is a highly multifunctional tool useful both in agriculture, carpentry, and, for example, chopping wood for the fireplace. Numerous parallels have been found in Pompeii, and it seems that this was an indispensable object in Pompeian households, of which most *domus* owned one (Table 1).³⁰

One iron tool is called ‘piccone’, a pickaxe (Cat. 471)³¹ in the *PAH*, translated in Latin as *upupa* by Minervini, who also describes it as so badly oxidized as to compromise its recognition; it is not mentioned by Falkener. Its length as given in the *Inventario San Giorgio*, 37.5 cm, is considerably longer than the examples of ‘piccozza’ from the house of the Menander, which are between 17.7 and 20.5 cm.³² Besides gardening, this tool could also have had more generic uses in the on-going construction work in the house, for example in the demolition of old structures.

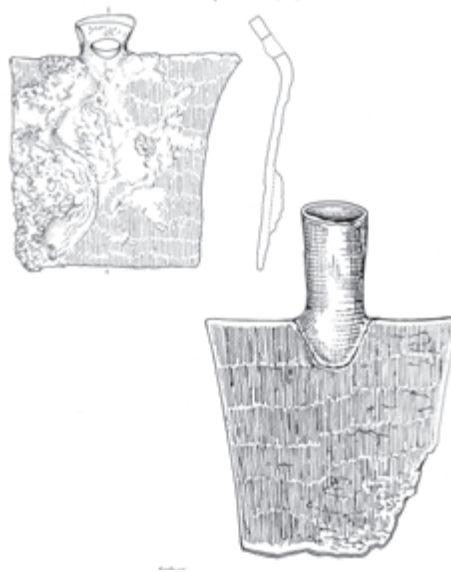

Fig. 32. A hoe (‘zappa’) and a shovel (‘pala’) from the insula of the Menander, Allison 2006, fig. 21–22.

²⁸ White 1967, 45–47; Allison 2006, 30; Stefani 2002, 102, with two examples from the Villa della Pisanella.

²⁹ Ciarallo – De Carolis 1999, 134, cat. 112; Pagano 2003, 200–201, cat. O7, inv. P20756 and O8, inv. P20754; Allison 2006, 451 et passim.

³⁰ Borriello 1999, 122, cat. 77.

³¹ Allison 2006, 27.

³² Pagano 2003, 199–200, cat. O4–O5.

Casa di M. Lucretius	Casa di Treb. Valens	Casa del Menandro	Casa di I. Polybius	Casa degli Amanti	Casa di M. L. Fronto	Casa dei Quadretti teatrali	Casa del Sacello Iliaco
555 m ²	500 m ²	1800 m ²	700 m ²	460 m ²	570 m ²	575 m ²	500 m ²
1 axe 3 chisels 2 hoes 2 hammers 1 plane 1 pickaxe 4 pruning knives	1 axe 1 hoe 1 pruning knife 1 rake	8 axes 2 chisels 12 hoes 3 pickaxes 14 pruning knives 1 shear 1 sickle 4 pick-axe 1 rake	none	1 axe 1 pruning knife 1 hammer	1 axe 2 hammers 1 hoe 1 shovel	1 axe 4 hoe 1 pruning knife	1 axe
14	4	46		3	5	6	1

Table 1. The amount of iron tools in select Pompeian atrium houses.

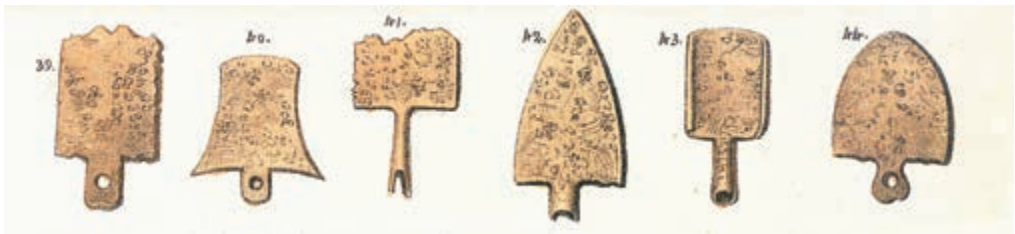

Fig 33. Ceci 1858, pl. X: hoes, 'zappa' (39–40) and shovels, 'pala' (41–42, 44), 'vanga' (43).

Among the most ambiguous iron tools found in the house are the three iron 'raschiatoie', or 'scrapers'. One of them (Cat. 155), L 22 cm according to the *Inventario San Giorgio*, is identified by Minervini as 'piccola pala forse per raschiare il suolo', "a small shovel perhaps to rake the ground", which gives the impression of rather a wide tool with a handle. It was found in the kitchen area and called a 'grater' by Falkener. The other two 'raschiatoie' (Cat. 469–470) were found oxidized together with two 'ronche' (Cat. 467–468) in the posterior part of the house. The word 'raschiatoia' can describe many kinds of tools with a sharp blade, but most probably this refers to the group with an elongated blade of triangular or tapering form, with the cutting edge at the tip, sometimes with concave sides, now called 'scalpelli', scalpels or chisels.³³ The lengths of such items found in Pompeii can be of ca 20 cm, corresponding to the measure given for Cat. 155 in the *Inventario San Giorgio*. Such tools were predominantly used by carpenters for the rough modelling of wooden surfaces, but they could also have been used by stone masons.³⁴ An important group of 24 iron chisels of different forms, certainly carpenter's tools, has given the name

³³ For chisels, Manning 1985, 8–9. 21–24; Allison 2006, 28.

³⁴ Borriello 1999, 125–126, cat. 89–94.

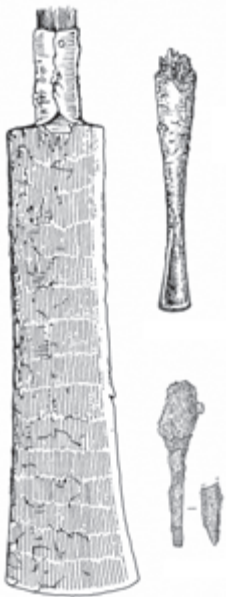

Fig. 34. Chisels from the house of the Menander, Allison 2006, fig. 29–31.

to the Casa del Fabbro, and several were found in the house of the Menander (Fig. 34).³⁵

Quite a unique piece is the plane, ‘pialla’, a carpentry tool, found in the posterior part of the house (III.3.1, Cat. 463). This item was unusual enough to be described in detail by Minervini, and also illustrated by Abbate in Niccolini brothers’ volume (Fig. 35). It is also shown in Carlo Ceci’s table on iron tools from the Naples Museum, with the provenience ‘from Pompeii’ (Fig. 36). The illustrations and the descriptions have made it possible to connect this lost find to a well-preserved specimen in the MANN collection, inv. 71964.

Hammers, of which two are mentioned in the *PAH*, were relatively rare in Pompeii; they could belong to a carpenter’s toolbox, but also be useful in construction work in general. The first was found in the *atrium*, and is described as a small hammer, with the length given in the *Inventario San Giorgio* as ca 21 cm (Cat. 17). The other (Cat. 466) was found in a non-specified location in the rear part of the house, evidently together with the plane.³⁶

The distribution of the ironmongery tools in the House of Marcus Lucretius shows two major clusters. The first is comprised of three objects found in room R4/R3: two pruning knives (Cat. 83–84) and a small axe (Cat. 80). These are part of the principal storage area finds from the house, and have a common functionality in cutting wood or tree branches. The single hammer (Cat. 17) allegedly found in the atrium R2 could also possibly belong to this group. The second cluster is without a clear provenience, as they were found in a non-specified location outside of the atrium complex, possibly in the servile quarters or in the surroundings of the upper atrium R29. These include both specialized carpentry (plane, Cat. 463; hammer, Cat. 466; two chisels, Cat. 469–470) and agricultural tools (two hoes, Cat. 464–465; two pruning knives, 467–468, a pick-axe, Cat. 471). Most of these could be useful in many types of construction work, including masonry, carpentry, and demolition. A plausible interpretation could be to see in this latter collection the



Fig. 35 (left). The plane from the House of Marcus Lucretius in Niccolini – Niccolini, 1854, pl. IV, 9. Fig. 36 (right). The plane in Ceci 1858, pl. X.1.

³⁵ Allison 2006, 186–187, pl. 86, 7–16.

³⁶ For the types of Pompeian hammers, Borriello 1999, 129, cat. 102; Stefani 2002, 102 (inv. 16956), from Villa della Pisanella.

tools used by a team working on the construction projects in the posterior part of the house, and thus a context of use, not storage. One further multifunctional item, a chisel/scraper/shovel (Cat. 155), was found in the kitchen area.

A numerical comparison with the reference group of Pompeian atrium houses places the House of Marcus Lucretius relatively high in the amount of hardware tools found (Table 1).³⁷



Figs. 37–39.

Catalogue

III.3.1 Iron plane (Figs. 35–40, Cat. 463)

MANN 71964 (San Giorgio 8787).

Dimensions: H 5.0; H max 7.0; L 21.8; W 6.0; W max 7.0.

Condition: The outline and form of the objects are well-preserved, although the iron sole and blade are very corroded, and the wooden core has been consumed on all sides. The top of the handle, which is also the top of the rear part of the stock, is broken and missing.

Bibliography: Mercer 1929, 115, fig. 110; *Pompeii AD* 79, 1978, 202, cat. 264; *Collezioni Napoli* 1986, 194–195, cat. 144; Borriello 1999, 127, cat. 96; Ulrich 2008, 15, fig. 3.2.

Description: The core of the tool is a rectangular wooden stock, wrapped in iron plating or sole (th. ca. 0.5 cm) at the top, bottom, and in front. A triangular slot is cut across the centre of the stock, into which the cutting iron blade is set, at

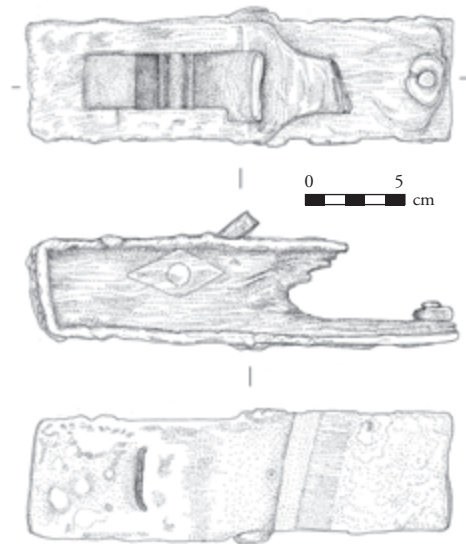

Figs. 40.

³⁷ All of the numbers, besides the House of Marcus Lucretius, are derived from P. Allison's database, the On-Line Companion to Roman Households, <http://www.stoa.org/projects/ph/home>.

an angle of 55 degrees. The cutting iron is 3.5 cm wide and 0.9 cm thick. Originally the blade would have been inserted into the slot, pushed below the horizontal iron rivet, and fastened in place with a wooden wedge. The end of the iron rivet is visible on both sides of the stock, and it is attached by a small diamond-shaped collar of bronze plate. The stock had one hand grip at the rear, consisting of an elliptical slot perforating the wood from one side to the other (l. ca 6 cm). The horizontal grip, 2.8 cm wide, that bridges above this perforation, is partly preserved.

Comments: Minervini noted that the tool is heavier than its modern counterparts, because it was coated in iron, and suggests it must therefore have served to smooth very large, hard, and rough pieces of timber. Indeed, the angle of its blade, between 50–60 degrees, is suitable for harder woods, as noted by Ulrich 2008, 45. For Roman planes in general, see Mercer 1929, 113–116, Ulrich 2008, 41–45. Numerous slightly later Roman planes (2nd century AD) have been found waterlogged at Saalburg (Germany), mostly in beechwood, and ca 20 examples in total are known from the Roman world, see Ulrich 2008, 43. On Roman planes, in general, see Gaitzsch – Matthäus 1981. 1st century AD.

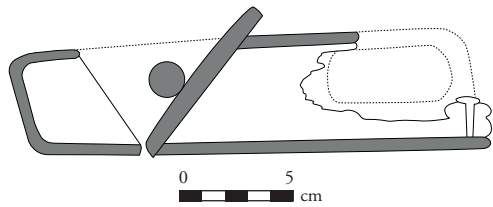

Fig. 41.

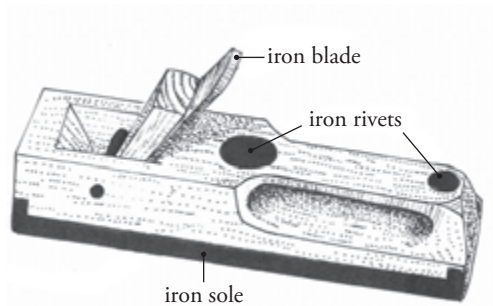

Fig. 42. Roman plane, modified from Ulrich 2008, 44, fig. 3.32.

III.4 Adornment and Valuables

Three items from the House of Marcus Lucretius can be classified as jewellery or other personal accessories. Only one gold object was found in the house, a small ring, possibly for a child, decorated with a green glass paste gem and a gold seashell (III.4.1, Cat. 48), in R4(3). The second piece of jewellery is a large bronze bracelet decorated with a wide silver plate, on which a radiate head of Helios is depicted (III.4.2, Cat. 305). The latter has been re-identified during this research in the collections of the MANN, on the basis of the drawing made of it by Abbate in Niccolini's volume. The bracelet was found in the garden area, in its upper layers, and probably originated in the first floor living quarters. Lastly, one bronze brooch (*fibula*), not located in the MANN and of a non-definable type,

belongs to this group (Cat. 243); it was also found in the garden area. Minervini is the only one to report the discovery of two iron bracelets, ‘due armille’.³⁸

All of the 40 coins reportedly found in the House of Marcus Lucretius are of bronze. Their descriptions as given in the *PAH* are scanty, and mostly they are only defined by size, dividing them in three groups, 3 small ‘modulo piccolo’ (Cat. 299, 329, 487), 12 medium ‘modulo mezzano’ (Cat. 15, 37–38, 71, 224, 281–282, 328, 441, 485–486, 501), and one large ‘modulo grande’ (Cat. 280). Among them, a coin of Claudius, of medium size (Cat. 224), was found in the left side of the tablinum. A small hoard of 23 coins was found in the recess of the upper atrium R29, but the coins are described only as being “of different sizes” (Cat. 366–387). This was the main hoard of the House of Marcus Lucretius; none were found in the cubicula around the atrium.

There were two money boxes found in the house. One (Cat. 279) contained three bronze coins: one large coin of Vespasian, a medium coin of Galba, and medium coin of Domitian (Cat. 280–282).

The money-box found in cubiculum R3/4, in the form of a safe-box, *arca*, is particularly elaborate (III.4.4, Cat. 72). A small glass paste disc with Medusa head in relief may have decorated a jewellery casket (III.4.3, Cat. 400).

Catalogue

III.4.1 Gold ring (Figs. 43–44, Cat. 48)

MANN 25044 (San Giorgio 455).

Place of discovery: Cubiculum R3/4 (March 23, 1847).

Dimensions: D outer 1.8; D inner 1.5.

Condition: Intact.

Bibliography: Breglia 1941, 82, cat. 714; Siviero 1954, 113, cat. 502, pl. 236e; Dwyer, 26, i, fig. 9; Berg 2008a, 118, fig. 8.6. See also Cat. 48.

Description: A small gold ring inlaid with a circular green gem in glass paste and an applied seashell shaped golden ornament. The shape of the ring is slightly oval.

Comments: No exact parallel has been found for the decoration. Plastic decoration is very rare in Roman jewellery, with the exception of snake forms. Another example is a gold ring with a theatrical mask in relief, found in Oplontis villa B (inv. Op 3398), d’Ambrosio – De Carolis 1997, 71, cat. 227, pl. XXIII. Date: 1st century BC–1st century AD.



Figs. 43–44.

³⁸ Minervini 1854, 20; 1855, 83.



Figs. 45–46.

III.4.2 Bracelet (Figs. 45–47, Cat. 305)

MANN 77180 (=s.n. 446), (San Giorgio 8332).

Place of discovery: Nearby the garden R18, in the upper layers (June 9, 1847).

Dimensions: D min 8.1; D max 9.4 of the hoop; Th.0.5 rod; D of the decorative plate 4.4.

Condition: Preserved intact. The bronze surfaces are covered with a green patina; the silver plate is partially deformed by superficial corrosion.

Bibliography: Minervini 1854, 19, drawing pl. IV, 4; Roberts 2013, 141–142, fig. 156 (without provenience).

Description: An expanding bracelet, with the hoop made of a single circular-sectioned rod tapering to either end with the two ends overlapping and then wound around opposite side with c. 2.5 turns. Cast in one piece with the decorative plate. The plate has a border with concentric moulded circles: at its centre, a slightly smaller, circular silver plate has been attached. The plate shows, in low relief, a frontal face, crowned by a set of rays, that identify him as Helios/Sol. Below the neck, a few horizontal lines indicate a vestment.

Comments: The bracelet was illustrated by Niccolini 1854, pl. IV, 4, 1854, and on the basis of this image (Fig. 6) it has been possible to recognize the bracelet currently identified merely as s.n. 446 as coming from the House of Marcus Lucretius. It is illustrated also in Ceci 1858, pl.



Fig. 47.



Figs. 48–49. Niccolini – Niccolini 1954, pl. IV, 4; Ceci 1858, pl. IX, 56.

IX, 56, only with the provenience 'Pompei'. As for its decoration, a parallel is offered by the famous gold bracelet from the Casa dell'Bracciale d'Oro, with the head of the goddess Luna in a similar medallion, decorating a massive snake bracelet. A loose medallion in gold, with two holes for attachment, from Herculaneum *fofnix* 11, depicts a similar head of Helios in low relief, d'Ambrosio – De Carolis 1997, 105, cat. 352, pl. XXXIII. Because of its material, bronze, such a large bracelet could hypothetically be identified as a male bracelet, possibly belonging to military insignia. 1st century AD.

III.4.3 Glass paste disc (Figs. 50–51, Cat. 400)

MANN 13648 (San Giorgio 2809).

Place of discovery: Cubiculum R30 (August 16, 1847).

Dimensions: H 1.2; D 4.5–4.8.

Condition: Intact, other than a small piece missing from the left rim. Slightly grey iridisation on the sides.

Bibliography: Dwyer, 50, I; Berg *et. al.* 2008, 208. See also Cat. 400.

Description: The disc is made of dark emerald colour, transparent glass paste. The underside is flat and plain. Above, on the decorated side, a raised ring runs around edge; in the centre there is a face surrounded by curly hair.

Technique: Relief image impressed on glass paste.

Discussion: Some parallels to glass discs with relief images of Medusa can be found outside of the Vesuvian area, for example a larger disc of D 15.3 from Rome, in the Corning Museum of Glass, see Harden 1987, 30 cat. 8. As for the possible functions of this piece, Harden suggests 1) furniture decoration, 2) an element of a wall mosaic/opus sectile, 3) a piece of decoration from the cuirass of a statue. The last suggestion is interesting, as the closest parallels to the present glass disc can, in fact, be found among the *phalerae* given as *dona militaria* and found mostly along the Northern limes. These would have been less valuable than the metal discs. Paunov (2017, 195–197) discusses such glass military *phalerae*, originally mounted on bronze frames or leather straps that hung over the military breastplate; in particular, a specimen slightly smaller than example from the House of Marcus Lucretius (D 3.9 cm), with three portrait heads of the Emperor Claudius or Germanicus (Municipal Historical Museum of Svištov, inv. I–1974). See also a *phalera* in blue glass, of D 3.7 with the bust of a Julio-Claudian prince, Harden 1987, 22–23, cat. 2 (British Museum inv. 1870,0224.2). In funerary portraits, such military decorations often depict Medusa heads. For other parallels for glass discs with Medusas, often identified as *phalerae*, see Newby – Schut 1999, cat. 28; Kunz 1981, cat. 340. 1st century AD.

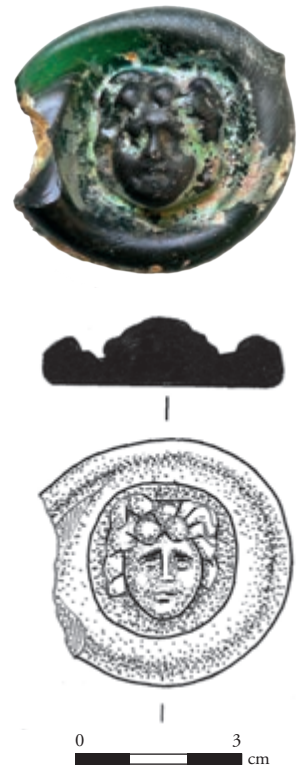

Figs. 50–51.

III.4.4 Terracotta money-box (Figs. 52–53, Cat. 72)

MANN 16813 (San Giorgio 5244).

Place of discovery: Cubiculum R3/4 (March 23, 1847).

Dimensions: H 8.4; L 12.3; W 7.5; Th. of wall ca 2 mm.

Technique: The money-box is covered on all surfaces with a reddish, slightly diluted matt slip (Munsell 2.5 YR 5/6 red), with finger prints as dripping marks. The light beige coloured clay is faintly visible under the slip.

Condition: The object is intact, save for a piece broken and missing at the edge of the hole for coins, on the top; the slip is somewhat worn along the edges.

Bibliography: Minervini in Niccolini 1854, pl. IV, 21; the same image has been copied in Daremberg – Saglio vol. 3. 2 s.v. *loculus*, 1293, fig. 4511; Graeven 1901, 168; Berg 2008, 104, fig. 8.1 c), Berg *et al.* 2008, 208. See also Cat. 72.

Description: The rectangular form, standing on four low feet, decorated with raised 'studs', imitates the appearance of a full scale safe-box. On the top, there is an oblong hole for the insertion of coins. On both sides of the hole, there are two 'studs'. The box is flat on top and ribbed round the sloping edges. Around these, there are 12 double impressed concentric circles, probably made by a circular metallic stamp that also left in each a faint circle of fine dots in relief. On the front side, there are two similar raised 'studs' on both sides of an impressed rectangle, representing the lock. The decoration is completed by a row of five circular impressions at the base of the front side.

Comments: The object is the only one of three money boxes from the house that has been currently found and identified. Some common globular money-jars in the collections of the MANN are without inventory number and might be from the House of Marcus Lucretius, but are beyond recognition. Rectangular money boxes are relatively rare. H. Graeven examined all of the examples in the collections of the MANN at the turn of the 20th century, and illustrated one very similar to the present item, 1901, 168, fig. 6 and 7. He counted, all in all, four examples of this type in the MANN collections (besides the present item, San Giorgio 5244, 4464, 6053 and one s.n.) and eight examples of the globular form (San Giorgio 4463, 4465–4467, 4469, 4470, 5130, 5677), among which our example must be included; three were stored in Pompeii. He notes that such utensils are not mentioned in Latin literature, and suggests that the money boxes may have been called *arculae*, as a diminutive for safe-box, *arca*, or *loculi*. A similar rectangular money box was displayed in the old Antiquarium of Pompeii, see García y García 2006, 187, fig. 433. On Roman money boxes in general, see Robinson 1924; Graeven 1901, 160–189; Cheilik 1963, 70–71; Williams 1984, 130–132.

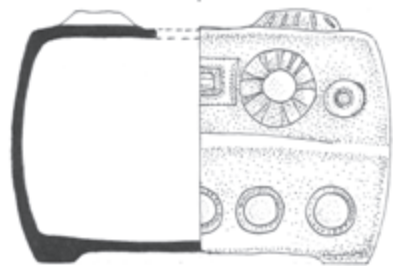
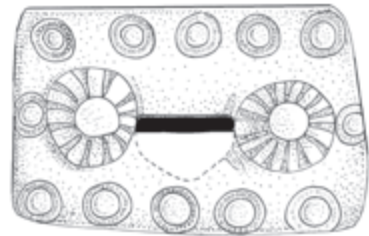

Figs. 52–53.

IV FIXTURES

RIA BERG

The category of fixtures comprises all the fittings listed in the old excavation documentation, i.e. metal or bone components that fixed, joined or completed other, normally wooden elements. The number of such catalogue entries is 162, making this numerically the largest group of objects found. It has not been possible to materially identify any object belonging to this group in the MANN collections. The fittings can be divided into three broad functional groups: 1) Closure elements, that are structural parts of doors or their locking systems, including 83 items: 45 hinges (25 strap hinges and 18 bronze cylinder-and-socket or pivot hinges or their parts, 2 cylindrical bone hinge groups), 33 locks, 3 keys, 2 bolts/latches 2) Elements relating to transport and equitation number 10 (9 cart/chariot elements and 1 horse bit). 3) Other (furniture) fixtures comprise 64 more generic items (30 nails, bosses, etc). Furthermore, 14 unspecified fixtures could not be classified into any of these categories. Other pieces of furniture, 5 in number, will also be discussed in this section (1 bench, 1 bed, 1 table, 2 altars).

IV.1 Closure Elements

Closure elements have the function of closing or locking interior spaces, whether rooms or mobile containers: they are parts of structural doors, shutters of vertical cupboards, or horizontal chests and boxes.¹ Their large number, 83 items (16,5% of all finds), reveals how central the function of safeguarding objects by locking them up in rooms and cupboards was in the Roman house.² In practice, this group mainly includes hinges and locks. Neither the *PAH* nor the other inventories, even though they consistently seem to report all such finds, give their exact measurements. Thus, it is quite impossible to make a coherent division between the fixtures belonging to doors, cupboards, and chests. Only when the piece has been described as ‘large’ is it assumed that it belonged to a door, and, inversely, that ‘small’ ones should belong to chests or boxes.

¹ For the doors, curtains, and isolating and closing systems in general, see De Carolis 2007, 27–40.

² Berg 2013; 2016.

Fig. 1 (above). Strap hinges. *Ceci* 1958, pl. IX, 34–35: “Scibba a due strisce acuminata e cerniera a quattro giuochi. Scibba a due strisce rettangolari unite da cerniera”.

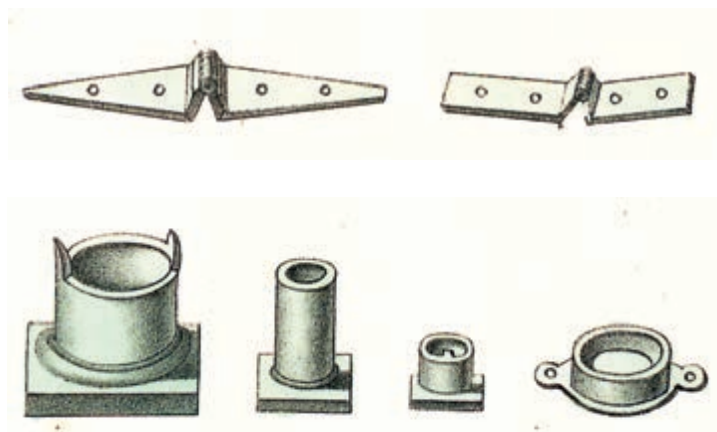

Fig. 2 (below). Pivot hinges. *Ceci* 1858, pl. IX, 50–53. “Bilico di cardine di porta colla sua piastra quadrilatera”.

The vocabulary in use in the middle of the 19th century for such fixtures was not univocal. The most numerous group, hinges, which includes 45 catalogued items, is divided into two major groups called ‘scib(b)e’ and ‘bil(l)ici’.

‘Scib(b)a’ can be interpreted as the modern Italian ‘cerniera’ or strap hinge, consisting of two arms connected by interdigitated pivot plates, pierced by the pivot pin (25 items, Cats. 5, 9, 33–34, 36, 55–59, 146–147, 152–154, 188, 242, 244, 248–249, 276, 327, 357, 396–397).³ The word ‘sciba’ is sometimes complemented in the PAH with the additional definition ‘a meccione’ (in five cases), and these items often appear as halves (Fig. 1). In some cases, the expression ‘sciba per lo stante della porta’ is used (nine cases), and these also often appear halved; they should be interpreted as particularly large door hinges. This same object is called ‘arpione da porta’ in *Annali Civili* (Cat. 9) – however, in the case of Cat. 64–67 the word ‘arpione’ is contradictorily used for pivot hinge sockets on plates; in fact, this text seems to use this word indistinctively for all kinds of hinges. When such items have been described in the *Inv. Fiorelli*, they may be further characterized as consisting of 3–4 ‘giochi’ that go around a pole, ‘perno’ (earlier called ‘meccione’), and having two “tails”, ‘code’. The tails coincide with the wings of a strap hinge.⁴

The word ‘bil(l)ici’, instead, refers to the cylindrical door hinge-sockets that in later inventories are called ‘cardini’.⁵ These are cylindrical bronze pivot linings on rectangular bases, and Falkener translates the word as “cylinder-and-socket hinge” (Fig. 2).

The rectangular base with pivot lining would be cemented into the threshold, in order to hold in place the pivot cylinder, to which the door poles were attached. Normally, doors consisted of two mobile parts, and would have required two poles on bases. All in all, 18 ‘bilici’ or pivot hinges are mentioned among the finds (Cat. 64–67, 97–98, 150–151, 229–231, 260–261, 275, 297bis, 325, 436–437); of these, 13 are complete, 4 examples are

³ For strap hinges, see Manning 1985, 126; Mols 1999, 55; Mastroberto 2003, 131, A25; Allison 2006, 30.

⁴ ‘Scibba a meccione’ has been interpreted by Amoroso 2007 simply as a door hinge combining wood and metal.

⁵ Allison 2006, 33, and cat. 285, fig. 53.1; pl. 18.5; De Carolis 2007, 37; Mastroberto 2003, 130–131, cat. A24.

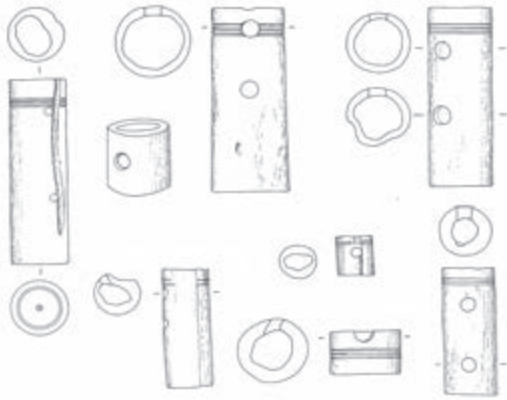

Fig. 3. Cylindrical bone hinges from the insula of the Menander. From Allison 2006, pl. 69.

missing the lower plate, and 1 plate was found without its respective cylinder. Assuming that two cylinder hinges are needed to make a door, the total quantity would sum up to ca. 8–9 doors. Four of them have been found in the cubacula at south side of the atrium, probably in R4 (perhaps for the doors of R3 and R4), two in cubiculum R5, two in ala R9/R10 (possibly for the door of R10), three in triclinium R16 (openings between R16 and R8), three in the garden area in or around R18, one in R19/20, and two, described as large, in the upper corridor R34.

A series of bone cylinders that were attached on one end to the shutter and on the other to the container itself, and through which a wooden or a metal pole was inserted, functioned as hinges for vertical cupboards (Fig. 3).

A group of ten cylinders (Cat. 19) was found in the atrium area, the total number suggesting a relatively small cupboard.⁶ A larger group of 26 (Cat. 216) comes from the area of the kitchen R11–14.

Locks and lock parts comprise 33 catalogued items. The generic expression ‘lucchetto’ – sometimes translated by Falkener as ‘the hasp of a lock’ (Cat. 120, 60–63, 191, 194, 295–296, 324, 389, 434), probably meaning some kind of latch mechanism, – appears 11 times by itself and in 4 other cases as an adjunct of ‘serratura’ (Cat. 6, 360, 429) or ‘mascatura col suo lucchetto’ (Cat. 250), meaning lock plate with lock mechanism. This should refer to common, fixed tumbler locks with their covering plates (Fig. 4).⁷ The generic word



Fig. 4. Locks and lock plates from Pompeii. Ceci 1858, pl. IX, 2–5: ‘serrature’ and ‘piastra di serratura’.

⁶ On bone and ivory hinges, see Mastroberto 2003, 125, cat. A14; Cool 2016, 172–178; Allison 2006, 30.

⁷ Manning 1985, 62–63; Mastroberto, 2003, 130, cat. A23; Allison 2006, 31–32; Cool 2016, 195–197.

'serratura', locking, never appears alone; as already mentioned, it sometimes appears along with the additional definition 'col suo lucchetto', lock mechanism (Cat. 6, 360), 'colla corrispondente mappa' (Cat. 479), or 'scudo di serratura', lock plate. The expression 'mappa di serratura' (Cat. 314–315), translated by Falkener simply as 'lock', should refer to the inner mechanism of the lock, the mobile perforated piece matched and moved by the pins of the key. This piece has also been called a 'corrente' or 'stanghetta' (hasp, bar) in later, 20th century inventories.

Of the various elements, the most numerous are the lock plates, which are called either 'scudo di serratura' or 'scudo di mascatura', and translated by Falkener as 'escutcheon of a lock'.⁸ The expression refers to the frontal lock plates, which might be circular or rectangular, always perforated by L-shaped keyholes, covering the lock mechanism. There are 14 catalogued lock plates without locks, with two of them defined as 'piccolissimi' and probably pertaining to smaller chests; one is circular and preserved complete with nails (Cats. 51–54, 116–117, 121, 167–170, 262, 297, 413). No further description allows us to identify their precise types or measurements, so they might belong to doors as well as chests or *armaria*.

A separate mention should be made of an iron lock (Cat. 407), found in R31, 'una mascatura a cassonetto', the measurements of which were actually mentioned: its width is 3/5 di palmo, 15 cm, and it was originally located in the *Medagliere* of the Naples Museum. This must have been an exceptionally large specimen. Cats. 314–315 are also made of iron; all the other locks are in bronze.

An exceptional closure element, called a 'zeccola', or bronze latch (Cat. 292), was found in the upper strata of garden R18.

The distribution of the lock elements was in various rooms: R1 1; R4(3) 8; R5 4; R11–14 5; R18 7 (5 in upper layers); R19/20 1; R29 2 (one in the recess), R 31 1; R 32 1; R34 2. The most notable concentrations, 12 elements in total, are to be found in the small front rooms of the atrium area, in R4(3) and R5. Another concentration of seven items can be seen in the garden area, particularly deriving from the top layers, and possibly from the rooms on the first floor. The third cluster, of five items, comes from the servile quarters R11–14, although these may as well come from the upper floor as well.

In addition, all three keys found in the House of Marcus Lucretius come from the servile area. Larger keys were mostly made of iron, and their conservation is therefore precarious. Only one iron key was found in the house (Cat. 181). The two bronze keys seem to have been found together (Cat. 159–160). An iron bar, ca. 70 cm long (Cat. 182) was reportedly found in the servile quarters, and interpreted as a door bolt.

⁸ Allison 2006, 31–32; Mastroroberto 2003, 128, cat. A19–A20; Cool 2016, 195–196.

IV.2 Other Fixtures and Furniture

This group includes the evidence of furniture fittings, primarily 13 pieces called in the *PAH* ‘guarnizione di mobile’ or ‘ornamento di mobile’. In addition, 30 nails (‘chiodo’) and 14 pieces of other fixtures, mainly studs and bosses (‘borchia’), have been included in this general group, although they may also have been used in doors or window shutters, for example.

Thirty nails are listed in total, but the number was actually somewhat higher, because some nails are listed as groups of an undefined quantity (Cat. 43, ‘chiodi ossidati’, thus probably of iron). Their description is generally minimal; most are in bronze (Cat. 28–32, 39, 173–175, 234, 245–246, 293, 300–3001, 430–433, 473), but eight are in iron (Cat. 22–25, 43, 118, 362, 472). The only formal differentiation sometimes given is the indication of a ‘large head’, ‘testa larga’ (Cat. 245–246, ‘piccoli chiodi con testa larga’), or a round, possibly hemispherical head (Cat. 234 ‘testa circolare’), or a hooked form, ‘chiodi uncinati’ (Cat. 472–473). Small groups also appear: two nails (Cat. 300–301), three decorative nails ‘per ornamento di mobile’ (Cat. 173–175), four nails (Cat. 22–25, 430–433), and five nails (Cat. 28–32). Several single bronze nails were also found (Cat. 39, 189, 293, 362). The distribution pattern of the nails interestingly runs counter to the expected find locations: none were found in the front cubacula, the primary storage area. Instead, a clear concentration of 11 nails appeared in the atrium R2. Other smaller concentrations were found in the rooms of the rear part of the house and the servile areas, R11–14 and R34.

Very few groups of items can be ascribed to pieces of furniture with any certainty. The most notable among these in the fragmentary couch found in triclinium R16 (Cat. 228). The various accounts give somewhat different descriptions of this important find. According to the *PAH*, the find consisted in part of organic materials – decomposed wood and remains of cushions – and in part of eight wooden legs covered with traces of silver plating, and silver bands in form of bracelets. Bechi claims that the bench went around three walls of the room and was fixed to the floor with nails, but this seems hardly possible for a piece of furniture with eight legs.⁹ Minervini adds the note that the legs had an iron core, and this is in fact plausible, as in the *Inventario San Giorgio* the items are described as made of silver-coated iron.¹⁰ The finding has been interpreted by De Carolis, in his study on Vesuvian furniture,¹¹ as a bench rather than a bed: type ‘panche A5’.¹² He includes the find in the category of *scamnum*, a stool or bench for one or more persons depending on its length. De Carolis cites the silver bands as proof of the use of lavish decorations in such pieces of furniture, in particular on their front feet (the silver ‘bracelets’ might have been

⁹ Bechi 1852, 10.

¹⁰ De Carolis notes that feet reinforced with iron are also mentioned for a bench found in the House of the Postumii VIII 4, 4.49.

¹¹ De Carolis 2007, 129. Cf. Mols 1999, 183–187.

¹² De Carolis 2007, 184.

applied only to the more visible four front feet), and groups it together with a find from the right ala of the Casa dei Postumi (VIII 4, 4.49), where a series of seats rather than one long bench was found. The eight feet preserved here are a quite rare case.

Besides the bench, only a passing note in Minervini records the possible presence of the remains of a bed in cubiculum R32 (Cat. 421).

The only possible remains of a table is the circular marble table (Cat. 44) mentioned by Falkener, who lists it among the objects fallen from the first floor around the atrium. However, the piece is not mentioned in the *PAH*, nor in later inventories in the MANN.

Furniture fittings must remain a vague group, as the bronze elements thus defined ('guarnizione di mobile', 'ornamento di mobile') are not characterized any further in the *PAH* (Cat. 149, 263, 298, 310–313, 484, 502). A bronze ornament of furniture from the area of the left ala or the garden (Cat. 149) was described as a small Herm, an ornament for furniture ('un piccolo Termine, ornamento di mobile'), and the *San Giorgio* inventory (inv. 8330) describes it further as a "youthful figure with vestments adorned with a Medusa head and snake", H 11.4 cm. One cylindrical furniture fitting in bronze is described in more detail in the *Inventario San Giorgio*, with a length of ca. 8.8 cm (Cat. 140). Two bone elements are similarly identified as 'guarnizione di mobile'. One is evidently a furniture decoration; it is described further in the *Inventario San Giorgio* (Cat. 40) as a piece 4 x 5 cm in size, with an incised palmette decoration. Another more elaborate bone fitting (Cat. 267) is described as a bone piece of ca. 4 cm, perforated, with a knob ('piroletto') at the top. This might be the finial of a series of bone hinges from a cupboard. Cat. 267 is an internally perforated bone piece 4.4 cm long.

A group of ten bosses or studs ('borchia') was found in the front cubiculum R6 (Cat. 125), and might belong to the decorations of a door.¹³ A group of eight studs (Cat. 428) was found in the fauces R34, and a single specimen (Cat. 461) is without a known find place. Seven disc-shaped studs in silvered bronze were found in the garden R18 (Cat. 308), one of diam. 6.5 cm; other finds include discs described as connected through attachments, one of them having a protruding bar, and one an attached ring with a heart-shaped applique. These might have been part of the decoration of the chariot, or a piece of furniture, most probably of a larger safe-box.

A group of five bronze rings (Cat. 70), found in cubiculum R4(3) could be related to curtains.¹⁴ Additional iron (Cats. 259) and bronze (Cat. 455–457) cramps and bars are fixtures of unknown function. Cat. 435 is a bronze fitting in swallow-tail form (altro pezzo a coda di rondine').

¹³ A similar group of ten studs, was found in the plaster cast of a door in the Octavius Quartio (II, 2, 2) De Carolis 2007, 29, Fig. 15.

¹⁴ Cf. finds from the Casa di Meleagro, De Carolis 2007, 33.

IV.3 The Chariot

A large group of finds from the upper tablinum R33 have been interpreted as elements of a chariot or a cart. The *PAH* lists ca. 60 bronze elements as belonging to this vehicle, while the *Inventario San Giorgio* lists 69 (Cat. 422). In addition, four iron felloes for wheels were found (Cat. 423–426). Possibly to be included in the group is an iron pole found nearby in R34 (Cat. 438). A couple of other iron bars had come to light earlier in the upper layers of the garden area (Cat. 316–317), together with a group of three iron bolts (Cat. 318), and these might also belong to this vehicle. Minervini discusses the discovery at length, suggesting that the remains might also belong to two two-wheeled chariots, rather than to one four-wheeled one. Besides the iron coverings for the wheels, Minervini also mentions, among other finds, fragments of axes in iron, ‘assi di ferro’, and gives more details on the different bronze elements that made up part of the chariot: bronze ornaments of various shapes, including small vases, discs, rosettes, and other figural motifs. In the MANN *San Giorgio* inventories, the lengths of these elements are given as 3–30 cm; unfortunately, the diameter of the wheels is not indicated. Also to be noted in this connection is a component of horse harness, a horse bit found in the garden area (Cat. 306), and, possibly connected, a bronze bell (Cat. 307).

Remains of chariots in the Vesuvian area are not numerous, as their structural framework were fashioned of easily perishable wood and iron (Fig. 5). The presence of four wheels could point to a heavier transport wagon, a *carrus* or *plaustrum*.¹⁵ The remains of a four-wheeled cart were found in the Villa Arianna in Stabiae, together with trace remains of another similar vehicle, in 1981; these have been interpreted as a *carrus*, used not in town

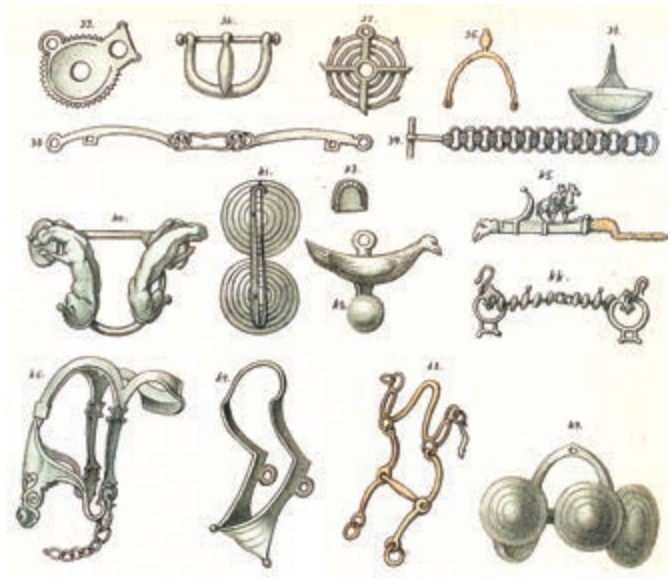

Fig. 5. A selection of bronze bells and elements of horse harnesses and chariots in the Archaeological Museum of Naples, Ceci 1858, pl. VII and IX.

¹⁵ Daremberg – Saglio s.v. *carrus*.

but to reach the villas outside of the urban network, by non-paved roads.¹⁶ The Stabian cart could have been used mainly for the transport of wine, as it was found with sherds of amphorae. A *plaustrum*, with four heavy wooden wheels, was found in the Villa Regina in Boscoreale.¹⁷ A single two-wheeled chariot, a *cisium* (width 98.7 cm), was found in the open back court of the House of Menander, near the stables.¹⁸ The courtyard was connected to the street by a 3-meter wide door. Of the chariot, the iron parts and some fragments of the wooden box were recovered, and imprints and felloes of the large and light wheels, along with 12 spokes of wheels. It remains a mystery how the chariot could have been taken into the upper atrium of the House of Marcus Lucretius, which is entered only through a narrow fauces. As possible solutions, it could be suggested that because of the construction work there was a breach in the upper atrium wall, allowing the passage of the chariot, as the vehicle would have to have been particularly narrow in order to fit through the fauces; or, it may have been disassembled and stacked in parts, out of use due to the unusual living conditions of the last days of Pompeii.

To be especially noted is that the use of decorations for the chariot was exceptional; the Menander *carrus* has some bronze studs of D 2.6 on the sides, whereas for the most part bronze decorations were reserved for the horse equipment. The presence of such figurative decorations points to a prestigious chariot for the status display of notable persons, not a transport wagon.

¹⁶ Miniero 1987; 1991.

¹⁷ De Caro 1983, 328.

¹⁸ Sodo 2003.

V ARCHITECTURAL ELEMENTS

RIA BERG

Structural finds, i.e. architectural fragments (or groups of them) collected as loose finds, number 18. They would obviously not have been a part of the *instrumentum domesticum*, but were rather loose items related to larger architectural features. The most notable single pieces are parts of the terracotta ceiling finials: in particular, a fragment of a gutter with a lion head, probably one of the spouts of the compluvium, identified in the present study (Cat. 226, Fig. 1). An antefix (Cat. 227) is mentioned by Falkener and Minervini, but not in the *PAH*.

A number of finds were identified as parts of the hydraulic installations of the house. Among them, there is a terracotta well-head or *puteal* (Cat. 341) from R23. According to the 1927 inventory book, listing large finds kept *in situ* in the House of Marcus Lucretius, a terracotta *puteal* was still present at that date. This is probably identical with the one conserved in the House of Marcus Lucretius in R23 until the latest restoration works. Fragments of lead water pipes (Cat. 225) are mentioned only by Falkener, who suggests that they might have come from the first floor around the garden area. A lead strainer – a perforated circular plate used to prevent detritus from entering water tubes – was found in R29 (Cat. 361).

Finally, two mosaic fragments were found in the atrium R2, and evidently derived from the upper floor (Cat. 47). One iron grate in the cubiculum R31 may have belonged to the window of this room, blocked after excavation (Cat. 406). A group of marble plates is recorded only in the *PAH*, as probably coming from the atrium, and possibly in connection with the mutilated marble statue found there (Cat. 14). As a hypothesis, they may have belonged to the lararium decoration, or the missing impluvium.



Fig. 1. Fragment of a gutter with a lion head (Cat. 226).

VI WALL PLASTER FRAGMENTS

VILLE HAKANEN

Introduction

The excavation campaigns of 2002–2006 in the House of Marcus Lucretius brought to light large numbers of wall and ceiling plaster fragments. In this chapter I first discuss the methods used to study the fragments. Then I give a brief summary of the decorative ensembles identified among the fragments and discuss their significance in the context of the House of Marcus Lucretius. The ensembles are described in more detail with possible parallels in the catalogue at the end of the chapter.

Methods

All the plaster fragments were counted and weighed after unearthing. In some of the trenches (CF12K1, CF29K1) a large proportion (roughly 40%) of the fragments were undecorated. On the other hand, the trench (CF2K1) under the atrium (2) contained almost exclusively decorated fragments. The fragments that had painting or stucco decoration were studied separately during the campaigns of 2009–2011 in order to find larger groups belonging to the same decorative ensembles and to be able to give them approximate dating. This classification was done using three principal criteria: decorative elements, composition of plaster, and archaeological context.

Archaeological context was the first criterion to be applied since the fragments had been sorted according to their find context, which was also respected during the documentation and analysis. Only in the cases where the archaeological stratification was practical, not actual, and the fragments were obviously buried contemporaneously could they be permanently recomposed according to the two other criteria. In all the cases, fragments identified as belonging to the same decorative ensemble were found within the same context or closely related contexts.

The decorative elements – colours, patterns, moulding profiles, etc. – and the composition of the plaster were the primary criteria for classifying the fragments. In the case of the largest and most representative decorative ensemble (No. VI.3) it was possible to find joining fragments and reassemble some parts of the wall. This was done both manually and digitally.¹ With the vast majority of the fragments, however, it was not possible to find joins that would have definitely linked particular fragments together. The lack of figurative

¹ See Häyhä 2008, 194–197.

elements other than simple lines or stripes on most of the fragments further complicated the puzzle. Fragments that by the archaeological context probably belonged to the same decorative ensemble but had different colouring could be linked based on similar pattern and execution, the composition of the plaster, and the quality of the finishing. Parallels within Pompeian wall decorations provided points of comparison when deciding which patterns probably belonged to the same decorative ensembles. Parallels were also used in the final analysis to propose potential dating for the fragments. The conventional category of four Pompeian painting styles is referenced for this purpose. Certain fragments were analysed by the plaster specialist Agneta Freccero, whose study confirmed the stylistic dating of several ensembles.²

Summary of the Identified Decorative Ensembles

Among the thousands of decorated fragments found in the excavations of the House of Marcus Lucretius, it has been possible to identify eleven groups or decorative ensembles consisting of more than ten fragments. One of the groups (No. VI.8) belongs to a ceiling decoration. The group (No. VI.3) includes a *cyma reversa* stucco moulding and another group (No. VI.1) consists mainly of fragments of stucco cornices and profiles.³ The following is a short summary of the eleven identified decorative ensembles. A more detailed account is given in the catalogue.

Four of the eleven ensembles belong to the First and Second Styles. Fragments of a representative First Style decoration (No. VI.2) were found under the second atrium (29) of the House of Marcus Lucretius. The profiled, colourfully marbled panels were probably part of the decoration of a single room in the late second - early first century BC.⁴ Another First Style decoration (No. VI.1), mostly consisting of elaborate stucco cornices and mouldings, was found in the garden (18) of the House of Marcus Lucretius. White cornices and profiled panels were combined with yellow and red fields and, possibly, with marbled fillets.

A large group of fragments belonging to a fine Second Style decoration (No. VI.3) also comes from the excavation of the garden (18). According to the preserved details it could have come from a single room. The decoration seems to have reproduced in painting an encrusted wall according to Beyen's "'canonical' form of the first phase [of the Second Style]" without illusionistic openings.⁵ Nor do the fragments show any painted columns,

² Freccero 2011. I would like to warmly thank Agneta Freccero for her generous help with the plaster analysis. The samples offered for her analysis were chosen at an early phase of the intensive study of the plaster fragments and consequently not all the most important decorative ensembles ended up being analysed. The responsibility for this shortfall is the project's alone.

³ Among the individual fragments there were many stucco mouldings that could not be linked to any ensemble.

⁴ A decoration with highly similar elements from the House of the Skeleton at Cosa is dated as late as 89–70 BC. Bruno – Scott 1993, 133–137, 146–148.

⁵ Beyen 1960, 60. As an entirely closed composition, the ensemble of No. VI.3 would belong to Beyen's phase Ia of the Second Style. Beyen 1938, 37–60.

other supporting structures, or any *trompe l'oeil* elements besides the blockwork. This relative simplicity cannot be used as a definitive dating feature,⁶ and it does not seem to suggest much about the status of the decoration considering the abundant use of the precious cinnabar red on the fragments.⁷ However, most of the possible parallels for the details of the ensemble of No. VI.3 belong to the first two of the three chronological categories of the Second Style by Heinrichs.⁸ Furthermore, one of the closest parallels for detail VI.3.3 is found in the paintings of the Casa dei Grifi, the earliest known wall paintings of the Second Style.⁹ This suggests that the ensemble of No. VI.3 should probably be dated earlier rather than later in the development of the Second Style. The real stucco moulding that probably crowned the decoration might survive from a preceding First Style decoration.¹⁰

Another group of fragments (No. VI.4) found under the second atrium (29) has a strikingly similar Second Style decoration of *trompe-l'oeil* panels to No. VI.3 but the quality of the plaster, the colours, and the hand of the painter are much less refined. Red ochre is used for the red fields instead of cinnabar, resulting in a clear difference in brightness. These two ensembles constitute an interesting pair of stylistically similar decorations that, however, have a remarkable difference in terms of quality.¹¹

The presence of the Third Style is quite marginal among the fragments. The ensemble of No. VI.6 from the kitchen area (room 12) has a vegetal motif, pink and brown lines and a tongue pattern on white. Its careful finishing and good quality plaster should place it into the Third or possibly early Fourth Style,¹² though the modest painterly execution suggests an environment of minor importance. Another probable candidate for the Third Style is a small group of fragments (No. VI.5) that comes from the upper layers of the garden (18).

A large group of fragments (No. VI.7), also from the garden (18), is part of a mainly purple decoration that certainly belongs to the Fourth Style since some of the fragments include yellow embroidery borders.¹³ Other fragments of the same group represent garlands and *trompe-l'oeil* mouldings. A group of ceiling fragments decorated with yellow

⁶ Heinrich 2002, 9–11.

⁷ Maguregui *et al.* 2010. Tammisto – Kuivalainen 2008, 84. For the use of cinnabar in Second Style decorations in Campania, see Meyer 2010, 34; Bergmann 2007, 249; Ling 1991, 209.

⁸ The “early walls” (*frühe Wände*) and “walls of the middle phase of development” (*Wände der mittleren Entwicklungsstufe*). Heinrich 2002, 20–45.

⁹ See Mazzoleni 2004, 73. For the dating of the decorations of the Casa dei Grifi, see Strocka 1991, 109.

¹⁰ Stucco mouldings might have belonged to either First Style or Second Style decorations or both because First Style cornices were sometimes conserved when the decoration was altered during the Second Style. Laidlaw 1985, 42; Heinrich 2002, 23–25. For stucco mouldings in Second Style decorations, see also Riemenschneider 1986, 26–40.

¹¹ It is possible that No. VI.4 is a later imitation of the Second Style (see below). However, the decoration of corridor 4 of the Casa del Labirinto (VI 11, 8–10) also has a simple Second Style scheme, which Mau (1882, 259–260) describes as done with little care, with less stucco and workmanship than the more important rooms of the house, some of which are sumptuous. Mau considers the decoration to be a later imitation of the Second Style, but Strocka (1991, 116, n. 636) rules this out. Consequently, it seems that the same phase of decoration could be comprised of both very high quality and very low quality wall paintings. Unfortunately, a sample from the ensemble of No. VI.4 was not offered for Freccero's analysis.

¹² The plaster is similar in all of the fragments and one that was examined by Freccero belongs to her group F (Third Style). Freccero 2011, sample no. 8.

¹³ See Ling 1991, 81–84 for the embroidery borders and the Fourth Style.

embroidery borders on white (No. VI.8) might have adorned the same room. Based on the plaster composition, the decoration of No. VI.7 probably pre-dates the earthquake of 62 AD.¹⁴

Two large groups of fragments (No. VI.9 and No. VI.10) from trenches in the garden (18) and the room (12) next to the kitchen apparently show a very simple tripartite or bipartite division of the wall painted with single lines. They probably belong to the so called “Nebenzimmer” decorations.¹⁵ The fragments of No. VI.9 show black and red bands and diagonals and brown borders on an unpainted white background. The decoration of No. VI.10 is also mainly unpainted with a spattered socle and black and red bands probably imitating elementary *candelabra*. A frieze of sloppily painted lotuses and palmettes crowns the scheme. “Nebenzimmer” decorations pose a problem of dating since they are less compatible with the typology of the painting styles. The ensemble of No. VI.10 probably belongs to the context of the Fourth Style based on both its closest parallels and the plaster, connected to the garden paintings of No. VI.11 by Freccero.¹⁶ No. VI.9 is more difficult to date and might belong to either the Second or the Fourth Style.¹⁷

The dominating group of fragments (No. VI.11), excavated under the main atrium (2), represents garden views and probably belongs to the decoration of a *viridarium*.¹⁸ The fragments show colourful foliage painted on black, yellow and blue backgrounds and a yellow *incannucciata* trellis fence on black. They might also include fragments of a bird. Parallel decorations in Pompeii suggest a dating in the context of the Fourth Style, which is suggested also by Freccero’s plaster analysis.¹⁹

The Decorative Ensembles and the House of Marcus Lucretius

The connection between the eleven decorative ensembles of the catalogue and the House of Marcus Lucretius is perhaps less obvious than it might seem. Some of the waste pits identified in Pompeii probably served the purpose of quarrying the *pozzolano* for making plaster.²⁰ The quarry would then have been filled with any material at hand. Recent excavations by the Stabian Gate have revealed that pits could also be filled with material from

¹⁴ Group G in the category of Freccero (2011, sample no. 12), which she thinks “probably belongs to the period [...] before the earthquake” (2009, 105).

¹⁵ The term “Nebenzimmer” is adopted from Strocka (1975, 101–114). In English scholarship it is used at least by Ling (1991, 2; 2005, 138), who translates it “subsidiary room”.

¹⁶ Freccero 2011, sample no. 9. Group G “probably belongs to the period [...] before the earthquake” (Freccero 2005, 105).

¹⁷ Unfortunately, a sample from the ensemble of No. VI.9 was not offered for Freccero’s analysis.

¹⁸ The finishing stucco layer of the fragments is made of crushed terracotta. The closest parallels of the ensemble are all *viridaria* (see catalogue), as are most of the spaces decorated with garden paintings around 62 AD in general (Michel 1980, 373–404).

¹⁹ Group G, Freccero 2011, samples no 10 and 11. Group G “probably belongs to the period [...] before the earthquake” (Freccero 2005, 105).

²⁰ Robinson 2005, 110–113; Dicus 2014, 60–61.

outside the site, from as far away as dumps outside the city walls.²¹ Another reason for dumping waste inside a house was renovation: floors were raised and foundation ditches for walls were dug and filled.²² It is also possible that a pit was dug especially to dump building debris, but this leads to the problem that soil must have been removed to make way. In every case, digging inside a house is probably a sign of wider building activity on the property and it would be reasonable to assume that wall plaster fragments found buried in the waste pits could come from demolition works carried out on the same site.

How does one tell, then, which of the plaster fragments excavated in the House of Marcus Lucretius originally came from its area and which did not? One indicator would be the coherence of the material itself. If there are numerous fragments from the same source (a single decoration) and fewer random fragments, it seems more probable that the fragments came from their original location without too many intermediary points. In this case the simplest scenario would be to presume a single owner for both the pit and the filling material and the shortest possible distance between the pit and the source of the filling material – both suggesting that the material came from the same site. If the material is more fragmentary it might come from a more arbitrary source. It is easy to come up with alternative scenarios for both cases, however, and the coherence of the material is also susceptible to the excavation conditions that in most of the cases did not permit digging the whole feature, both in terms of width and depth, that had been used to dump the plaster fragments in antiquity.²³ Furthermore, even the largest groups of fragments identified in the House of Marcus Lucretius represent only small parts of the decorations they originally belonged to and even though they stand out in their archaeological contexts, the same contexts often also included many random fragments or small groups of fragments. In any case, to me it seems probable (though far from certain) that the largest ensembles came from the area of the House of Marcus Lucretius. The extensive renovation and construction works that were carried out, probably after the earthquake of 62 AD, and resulted in the House of Marcus Lucretius as we know it must have required digging of both the *poz-zolano* and foundation ditches and created extensive demolition waste. The various painting styles in the excavated fragments could represent the situation before 62 AD when the area of the House of Marcus Lucretius was probably a somewhat eclectic collection of three or more earlier houses.²⁴ All the Pompeian styles might have coexisted in these houses, but the fragments of the highest quality belong to the First and Second Styles.

From these premises it is possible to draw some hypothetical conclusions. The Third Style decorative ensemble of No. VI.5, which has the smallest number of fragments, has

²¹ Dicus 2014, 61–62.

²² See Dicus 2014, 62–63.

²³ Only CF29K1 was excavated completely. For the problems of interpreting material from waste pits, see Dicus 2014, 63–68.

²⁴ Houses nos. 5 and 24 were separate houses until the first century AD. At some point before their unification, certain rooms of house 24 had been part of the neighbouring houses 23 and 25. The area of rooms 10–14 was added to the House of Marcus Lucretius around the time of the unification. Viitanen – Andrews 2008, 58–61.

the least probable connection to the House of Marcus Lucretius. It was found in the upper layers of the garden, among the garden soil that was deliberately developed using household waste. This context, dating to the last phase of the house, included only random individual fragments and the fragments of No. VI.5.

The other identified groups are larger and their archaeological contexts are more consistent. The First Style fragments of No. VI.1 were found in the oldest excavated context of the garden (SU18.129). They might belong to an earlier pit that was disturbed in the last phase during the construction of the S-wall of the garden. Ceramics date the pit to the 1st century BC and it is therefore an interesting documentation of an early renovation of a finely decorated house possibly in the area of the House of Marcus Lucretius. Although the fragments of No. VI.1 represent but a tiny fraction of the original decoration, they are the only fragments in the pit, making its contents exceptionally homogeneous.

Waste pit CF29K1 in room 29 was quite probably dug especially for demolition material from a late renovation of the house. This is indicated both by the structure and the contents of the pit, which is shallow, just beneath the last floor level and breaking the earlier floor surfaces, and filled with homogeneous building debris including the large First and Second Style ensembles of Nos. VI.2 and VI.4. Room 29, the second atrium of the House of Marcus Lucretius, belongs to the house's northern annex that was originally a separate atrium house (24) but had been incorporated into the House of Marcus Lucretius apparently by the time of the digging of the pit. The walls of room 29 were decorated with now vanished Fourth Style paintings. If the fragments of Nos. VI.2 and VI.4 decorated the walls of house 24, as seems likely, and were replaced by the Fourth Style paintings, they must have been on the walls until relatively late and for quite some time.

At some point, before being taken over by the House of Marcus Lucretius, house 24 (room 29) had been connected to the neighbouring house 23 (room 129). A door that was later walled-up, perhaps when houses 24 and 23 were separated, connected rooms 129 and 128 on the side of house 23. Therefore rooms 29, 129 and 128 could have belonged to the same property at some point before 62 AD and the ensembles of Nos. VI.2 and VI.4 could have decorated this combination house. This leads to the interesting possibility that a set of Second Style paintings decorating room 128 might belong to the same phase of decoration as the fragments of No. VI.4. The composition of the plaster of the two decorations supports this possibility.²⁵ Neither decoration seems to have been of the highest quality and Mau dubbed the paintings of room 128 "a later imitation" of the Second Style.²⁶ If we approve Mau's judgment, the fragments of No. VI.4 could also fall into the same category.²⁷

²⁵ The decoration of room 128 is in very poor condition but fragments of well-preserved plaster have been preserved underneath the stonework of the walled-up doorway between rooms 128 and 129. Unfortunately a sample from the ensemble of No. VI.4 was not offered for Freccero's analysis.

²⁶ Mau 1882, 259–260.

²⁷ This could explain the remarkably poorer quality of the fragments of No. VI.4 compared to the securely Second Style fragments of No. VI.3. Mau's opinion is based on the construction phases of the S-wall of the room 128 (Mau 1882, 104, 283). He compares the scheme of the decoration of room 128 to corridor 4 of the Casa del Labirinto (VI 11, 8–10), which he also considered a later imitation (Mau 1882, 259–260) followed by Schefold (1957, 126: "vespasianischer 2. Stil").

Pit CF29K1 also included the smart First Style fragments of No. VI.2. They suggest that there was a reasonably well decorated house in this area already by the early first century BC. The individual fragments from the pit CF29K1 are monochrome and thus no styles other than the First and the Second definitively emerge.

Pit CF12K1 was in room 12 next to the kitchen, just beneath the last phase floor and aligned with the late walls of the room. It included two decorative ensembles: the Third Style fragments of No. VI.6 and the large Fourth Style “Nebenzimmer” painting of No. VI.10. Besides the identified ensembles, the pit contained a selection of low quality stucco mouldings, numerous unpainted ceiling fragments with reed imprints (*cannucciato*) on the background and many unpainted or monochrome fragments. Four of the latter were considered to belong to the First Style by Freccero.²⁸ Rooms 11 to 13 were a late addition to the House of Marcus Lucretius, probably following 62 AD. The N-wall of room 12 is old (first century BC) and conserves a small fragment of fine plaster compared to the coarse mortar of the later walls. This indicates that there might have been a decorated room in this place before it was taken over by the House of Marcus Lucretius. Hypothetically, the fragments of No. VI.6 or the monochrome First Style fragments could have been part of its decoration.

A possible pit CF2F was excavated under the floor of the main atrium (2) of the House of Marcus Lucretius. It was over one metre deep (the excavation could not be continued deeper due to its narrow structure) and filled with heterogeneous building debris including the large group of fragments (No. VI.11) that belongs to a garden painting. A suitable place for this decoration would have been a *viridarium*²⁹ and the only potential candidate nearby is the garden of the House of Marcus Lucretius. According to Freccero, the plaster composition of the fragments of No. VI.11 is identical to the “Nebenzimmer” fragments of No. VI.10.³⁰ Although this type of plaster “probably belongs to the period between 45 and 62 [AD]”,³¹ the clearest parallels of both of the decorations are almost all post-62 (see catalogue). The decoration of the fragments of No. VI.10 is very modest and the quality of the plaster poor. The garden painting No. VI.11 seems to have been more elaborate although the fragments show no figure paintings besides the vegetation, the grid of the fence and a probable bird and a *candelabrum*. These two contemporary, perhaps even connected, decorations belonged to the last phase preceding the earthquake of 62 AD and, if originating from the area of the House of Marcus Lucretius, would seem to sug-

However, doubt on this view, and consequently perhaps also on Mau's view about room 128, is cast by Strocka (1991, 116, n. 636) who rules out Mau's conclusion.

²⁸ Two associable unpainted fragments, one black corner fragment belonging to a group of 45 black fragments, and one yellow fragment possibly belonging to a group of several yellow fragments. They all belong to group Aa of Freccero's typology. Freccero 2011, samples no. 1–4.

²⁹ The finishing stucco layer of the fragments is made of crushed terracotta. The closest parallels to the ensemble are all *viridaria* (see catalogue), as are most of the spaces decorated with garden paintings around 62 AD in general (Michel 1980, 373–404).

³⁰ Belonging to group G of Freccero's typology and in her words “the same”. Freccero 2011, samples no. 9, 10, and 11.

³¹ Freccero 2005, 105.

gest that the quality standards of the decoration were not very high at this point. Besides the fragments of No. VI.11, pit CF2F contained scattered, colourful fragments probably belonging to at least the Second and the Fourth Style, possibly also to the First Style.

The excavation of the garden (18) of the House of Marcus Lucretius was the most fruitful in terms of plaster fragment finds but also the most complicated to interpret archaeologically. Besides the small groups of Nos. VI.1 and VI.5, it presented the larger decorative ensembles of Nos. VI.3, VI.7, VI.9, and the ceiling fragments of VI.8. The garden grounds were obviously the easiest place in the house to dump material and the soil was worked several times during the late history of the house. The four large decorative ensembles all come from trench BC in the northeast corner of the garden. They belong to possibly four contexts (CF18K2, CF18K3, CF18K4 and CF18K7) that, however, have been mixed and are hard to tell apart. Pit CF18K2 cuts through the waste pit CF18K4 and possibly CF18K7 and it might have been dug for building the foundation of the fountain complex during the last phase of the house. All the pits contained mostly building debris.

Of the identified decorative ensembles, the beautiful Second Style decoration of No. VI.3 probably dates to the 80s–60s BC. The “Nebenzimmer” decoration of No. VI.9 might belong to either the Second or the Fourth Style while the fragments with “embroidery borders” of Nos. VI.7 and VI.8 are definitely Fourth Style and date to the decade or so preceding the earthquake of 62 AD. If the fragments had their origin in the area of the House of Marcus Lucretius, they draw a picture of a house or houses with high quality wall decorations during the early first century BC. At the beginning of the Fourth Style the house or houses received a modest decoration (no figurative elements among the fragments) but some parts of the earlier Second Style decoration might have been conserved until the earthquake of 62 AD and the following construction of the final House of Marcus Lucretius resulted in the demolition and burying of all of these decorations. Besides the four large decorative ensembles, their archaeological contexts contain parts of First Style fillets and a tongue pattern cornice made of low-quality stucco, a few random wall plaster fragments and several pieces of four different *cocciopesto* floors.

Catalogue

The catalogue of the proposed decorative ensembles follows their stylistic attribution to the four conventional Pompeian painting styles and two additional categories: “Nebenzimmer” decorations³² and garden paintings. The description of each ensemble begins with the dominant details and – if the original location on the wall is clear – proceeds from the bottom of the wall to the top. All dimensions are given in centimetres. The colours are given as they appeared to the bare eye at the moment of documentation. Their conserva-

³² The designation “Nebenzimmer” is adopted from Strocka (1975, 106–114). In English scholarship, it is used at least by Ling (1991, 2; 2005, 138), who translates it “subsidiary room”.

tion and brightness was generally excellent (see the radiant cinnabar red of No. VI.3) but clearly depended to some degree on the quality of the decoration (see No. VI.10) and the level of exposure in the original context (see No. VI.5 coming from the ancient garden soil). White is listed as a colour in the cases where it is clearly paint. In Nos. VI.1, VI.2, and VI.5–10, unpainted fields of white plaster are called plain white. Freccero's plaster typology is referenced whenever she has personally analysed the plaster of one of the fragments of the ensemble.

Abbreviations used in the catalogue:

H = height

L = length

Pr. = projection

Th. = thickness

W = width

First Style (Nos. 1–2)

VI.1. Cornices, Yellow and Red Fields, Marbled Fillets (Fig. 1.1–10)

Archaeological context: Garden (18), trench BD (SU 18.129).

Quantity of excavated fragments: ca. 30.

Colours: Red, yellow, light blue, pink, black, brown, green.

Plaster: Finishing stucco layer is creamy white and hard with numerous crystals, Th. 0.2–0.8 cm (high variation in the cornices). The plaster is dark, made of small grained, rounded stones. The plaster of the dentil cornice belongs to group Aa (First Style) in the typology of Freccero.³³

Parallels: For the individual elements see below.

Dating: 175–100 BC.

Description and comments: The ensemble consists of several stucco mouldings, dozens of monochrome red and several monochrome yellow fragments and 14 fragments of colourful marbling, four of which belong to a fillet. It is not certain whether all the fragments belong to the same decoration.

Fourteen small marbled fragments (VI.1.1) contain two or three different patterns: four fragments belong to a profiled fillet (H 2.8 cm) with diagonal brush strokes of yellow, red, light blue and brown;³⁴ six fragments have a candy pattern painted with black on a light blue, pink, red, yellow and green background; three fragments have a larger curvy pattern in black, pink and red. Two fragments (VI.1.2–3) with nearly identical cyma reversa mouldings (Pr. ca. 5 cm) conserve a slice of bright yellow and bright red field below the moulding. Several yellow and red monochrome fragments might belong to these fields that would have formed the fasciae underneath the moulding. One fragment (Fig. 1.4) shows a shallow, elaborately profiled corner of a drafted panel with a broken or uneven top level. Two fragments (VI.1.5–6) belong to a moulding with a similar profile

³³ Freccero 2011, sample no. 5.

³⁴ Similarly marbled fillets of different size were found during the preliminary clearing of room 33 of the House of Marcus Lucretius. Because of their modern context it is impossible to trace their origin.



Fig. 1.1-10.

as Laidlaw's pl. 3 *b*, but of about half the size. Four fragments (VI.1.7–10) probably formed a variation of the dentil cornice in Laidlaw's (1985) pl. 6 *b* (Pr. ca. 20 cm). However, the part below the dentils is unusually deep and convoluted.³⁵ The cornice would have crowned the upper zone of the decoration. There are reed imprints (*cannucciato*) in the plaster as rendered in the cross-section of fig. 3 in Laidlaw (1985, 22).

VI.2. Profiled Marbled Panels, Cornices (Fig. 2.1–8)

Archaeological context: Second atrium (29), pit CF29K1.

Quantity of excavated fragments: over 100.

Colours: Green, purple, yellow, brown.

Plaster: Finishing stucco layer is creamy white (yellowish) and hard with numerous crystals, Th. 0.2–0.5 cm, 0.1 cm in the dark yellow fillet. Different coats of plaster are visible in the thicker fragments. The plaster is black, made of small grained, rounded stones with many inclusions of lime. In the lower coats there are inclusions of larger stones.

Parallels: The House of the Skeleton at Cosa.³⁶ Various parallels for the individual elements (see below).

Dating: 175–70 BC.

Description and comments: The fragments belong to four details of a painted decoration and to a few stucco mouldings that imitate marble blockwork.

The part of the decoration with the largest quantity of fragments (VI.2.1) consists of a drafted panel or panels (Pr. 0.3 cm) in ocean green with darker, bush-like marbling and tiny purple and yellow spatters.³⁷ A dark purple fillet (W 3.2 cm) runs around the panel. Another large group of fragments (VI.2.2) shows similar bush-like marbling in brown with tiny purple spatters on a creamy yellow background. Two of these fragments have been broken along a profile suggesting that they were probably also part of drafted panels. A third group (VI.2.3) shows a drafted panel or fillet with alabaster-like marbling of purple, green and yellow ovals on plain white background. The panel is bordered by a ca. 5 cm wide dark yellow fillet, partly turned to red in one of the fragments (because of fire?). Several fragments (VI.2.4) show plain white drafted fillets (H 0.3–0.5 cm) bordering dark purple or ocean green fields. Four fragments (VI.2.5) belong to an elaborate dentil cornice with reed imprints (*cannucciato*) in the plaster.³⁸ Among the fragments are also three cyma reversa mouldings (VI.2.6–8; Pr. ca. 4 cm in VI.2.6, VI.2.7 slightly smaller and VI.2.8 slightly larger).

Second Style (Nos. 3–4)

VI.3. Trompe l'Oeil Blockwork (Fig. 3.1–5)

Archaeological context: Garden (18), trench BC, pits CF18K2, CF18K3, CF18K4 and CF18K7.

Quantity of excavated fragments: over 500.

Colours: Red (cinnabar),³⁹ yellow, green, black, purple, white.

Plaster: Finishing stucco layer of details VI.3.2–6 is creamy white and hard with numerous crystals,

³⁵ See Laidlaw 1985, pl. 4–9; Riemenschneider 1986, fig. I–XVI.

³⁶ Bruno – Scott 1993, 133–137, 146–148. Dating of the decoration is as late as 89–70 BC.

³⁷ The bush-like marbling is similar to the pattern in the doorpost of the *fauces* of Casa del Fauno (marbling *f* in Laidlaw 1985, 179, pl. 70 c) and in the orthostats of the *tablinum* of House VI 16, 19/26/27 (Laidlaw 1985, pl. 46 a).

³⁸ The reed imprints as rendered in the cross-section of fig. 3 of Laidlaw (1985, 22).

³⁹ Maguregui *et al.* 2010; Tammisto – Kuivalainen 2008, 84.



Fig. 2.1-8.

Th. 0.4–0.5 cm. Detail VI.3.1 has two layers of finishing stucco (combined Th. 0.2–0.5 mm): the lower layer is made of finely crushed terracotta while the top layer has the same creamy yellow stucco with numerous crystals as details VI.3.2–6. The plaster is made of dark sand with large grain size and lumps of lime. It belongs to group B (First–Second Style) in the typology of Freccero.⁴⁰

Parallels: No. VI.4. Parallels for the individual details below (see especially detail VI.3.3).

Dating: 100–20 BC.

Description and comments: The largest and most representative decorative ensemble found in the House of Marcus Lucretius consists of five details of a two-dimensional painted decoration that imitates masonry blockwork and stucco mouldings. One of the details (VI.3.5) includes a real cyma reversa moulding with a purple fascia. It is not sure whether all the details come from a single room but it is possible since they seem to comprise a reasonable Second Style decoration from the socle to the stucco moulding by the ceiling. However, the fragments come from more than one wall because details VI.3.4, and 3.5 have light coming from opposite sides.⁴¹

VI.3.1 Over 130 fragments show a yellow field with red, white, green and black spatters. In a few fragments, the spattered field is bordered by a black field. The correct place for spatters would have been the socle. This location is confirmed by the finishing stucco layer that includes crushed terracotta. All the decorations with a spattered socle in Heinrich's catalogue have either purple or black background,⁴² and the combination of a yellow socle with a darker main zone, as in detail VI.3.2, would be untypical of the early Second Style.⁴³ However, several simpler walls (with only two of the usual three horizontal zones) have an entirely yellow socle already in the early phase of the Second Style,⁴⁴ and a yellow socle with a darker main zone seems to be more common in the middle phase of the style.⁴⁵

VI.3.2 Over one hundred fragments show a dark purple panel profiled with white and black lines representing highlight and shadow. A bright cinnabar red frame runs around the panel. Several fragments show a narrower green panel on the other side of the red frame. The green panel is also profiled with white and black lines. There also seems to have been a dark purple panel with a cinnabar frame on the other side of the green panel. One fragment shows the lower part of a trompe l'oeil moulding (probably cyma reversa) above the cinnabar frame and a slice of a green panel. The proportions of the decoration and the fact that only one corner of a panel is preserved suggest that the panels were few and large and thus might have been part of the orthostats that were alternately large purple and narrow green, surrounded by cinnabar red frames. This scheme has several parallels among Pompeian decorations, though the colours are never exactly identical with our fragments.⁴⁶

⁴⁰ Freccero 2011, samples no. 6 and 7.

⁴¹ The highlighted profiling of the panels of the decoration depends on the light source of the room so that the white sides of the square face the light.

⁴² Heinrich 2002, 15, cat. 4, 5, 18, 20, 24, 56, 70, 84, 93, 109, 110, 112.

⁴³ Heinrich 2002, 27.

⁴⁴ Heinrich 2002, 47.

⁴⁵ At least Heinrich 2002, cat. 33, 34.

⁴⁶ Numbers 17, 25, 32, 82, 93 and 112 of Heinrich's catalogue (2002) have orthostats of this kind. Numbers 6, 8, 16, 72 and 108 have similar orthostats but the proportions of the profiling of the narrower panels are slightly different. Numbers 64 and sections of numbers 16 and 17 have the same colours (purple, red and green) in the orthostats. Some rooms (*cubicula* 4, 8 and 16, the hall of the mysteries) of the Villa dei Misteri have orthostats in purple, red and green, although the green is quite bluish and some details like frames might be in yellow.



Fig. 3.1–5.

A painted moulding probably crowned the orthostats. Dozens of monochrome purple fragments from the same context probably belonged to the purple blocks.

VI.3.3 Over one hundred fragments belong to this detail that is the most elaborate part of the preserved decoration and its only distinctive detail. Twenty-four of the fragments were joining and could be assembled and thus the pattern is quite clear. It constituted the frieze between the middle and upper zones of the wall. Starting from the bottom, the painting in the fragments represents a trompe l'oeil cyma reversa moulding that supports a row of black panels profiled with grey lines and surrounded by cinnabar red frames. Above the row is an oblong horizontal marble panel against a

black background. The light purple panel has white cyma reversa frames. The upper and left sides of the frame are in shadow and the light purple of the panel has likewise been shadowed by a row of darker purple dots along its upper frame. A couple of fragments show that the upper frame forms a higher trompe l'oeil cornice explaining the shadow. The source of lightning is on the right. Several decorations, mostly of the early–mid phases of the Second Style, show a similar set of panels between the upper and middle zones. The lower row is usually composed of wide horizontal panels which might alternate with square or narrow vertical panels in a different colour.⁴⁷ In most of the decorations the upper row is just a continuous purple or red (sometimes bluish green) field between two horizontal trompe l'oeil mouldings without vertical partition and is identified as the frieze by Heinrich.⁴⁸ In a few decorations this frieze is articulated into wide panels, as in our fragments: either complete quadrangles or with the other side cut before the side frame by a painted column or an actual corner of the room.⁴⁹ The cornice crowning these panels or field is usually quite elaborate and casts a similar shadow as in our fragments, though here it was probably simpler.

VI.3.4 Over one hundred fragments, some of which are bonding, show a yellow panel profiled with white and black lines representing highlight and shadow (in the inner square purple lines replace the black lines). The highlighting suggests that the light source of the wall was on the left. A bright cinnabar red frame runs around the panel. Above the frame is the lower part of a trompe l'oeil moulding (probably cyma reversa) that crowned the probable row of panels and confirms its orientation. The profiling and frames of the yellow panel seem too simple for the orthostats⁵⁰ while the presence of the moulding could indicate a position in the upper zone.⁵¹ The finishing stucco coat does not include terracotta, which probably rules out a location in the socle. In three fragments there is a black field on the other side of the cinnabar frame. If the panels of detail 3.4 formed a row on top of detail 3.3, this could have been a black fillet above the crowning cornice of detail 3.3.

⁴⁷ In the earliest decorations – rooms 2 and 4 of the Casa dei Grifi (Mazzoleni 2004, 67, 73–76) and *cubiculum* 8, *cubiculum* 4 and *oecus* 6 of the Villa dei Misteri (Beyen 1938, figs. 13–15b) – the panels of the row are alternately wide horizontal oblongs and small squares in two alternating colours or, once, monochromatic in bluish green. In the alcove of *cubiculum* x of the Casa delle Nozze d'Argento (V 2, 1) the wide oblong panels are black as in our No. VI.3 (Heinrich 2002, cat. 33, fig. 81). *Fauces* a, *cubiculum* c, *ala* f and *cubiculum* g of the Casa di Cerere (I 9, 13) have alternating wide horizontal panels and small square or narrow vertical panels in green, yellow, red, and faux-marble (Heinrich 2002, cat. 10, 12, 15, 16, figs. 15, 19, 25, 27, 29–30). *Cubiculum* l of the Casa detta di Trebius Valens (III 2, 1) belonging to Heinrich's late phase of the Second Style also has a similar scheme composed of marbled panels (Heinrich 2002, cat. 28, figs. 66, 68).

⁴⁸ Room 2 of the Casa dei Grifi (Mazzoleni 2004, 74–76), *cubiculum* 8 of the Villa dei Misteri (Beyen 1938, fig. 13), *fauces* a, *cubiculum* c, *triclinium* d, *ala* f and *cubiculum* g of the Casa di Cerere (I 9, 13) (Heinrich 2002, cat. 10, 12, 13, 15, 16, figs. 15, 19, 23–25, 27, 29a–30), *cubiculum* l of the Casa detta di Trebius Valens (III 2, 1) (Heinrich 2002, cat. 28, figs. 66, 68). In *cubiculum* 4 of the Villa dei Misteri, the alcove of *cubiculum* g of the Casa di Cerere (I 9, 13) and *cubiculum* x of the Casa delle Nozze d'Argento (V 2, 1) there are fantastic sculptural supporting structures between the two faux-mouldings (Beyen 1938, fig. 11; Heinrich 2002, cat. 16, 33, figs. 29a–30, 81, 82).

⁴⁹ Complete quadrangles: room 4 of the Casa dei Grifi (Mazzoleni 2004, 73), *oecus* 6 of the Villa dei Misteri (Beyen 1938, figs. 15a–b, 17) and *ala* 7 and *cubiculum* 46 of the Casa del Labirinto (VI 11, 8–10) (Strocka 1991, figs. 114, 357, 358), though in some the colour of the panel is not purple. Panels with the other side cut: room 45 of the Casa del Labirinto (VI 11, 8–10) (Strocka 1991, figs. 326–29) and some of the walls of room 8 of the Villa dei Misteri (Beyen 1938, fig. 13).

⁵⁰ Cat. 53 in Heinrich (2002, fig. 97) has yellow orthostats surrounded by red frames and crowned by a trompe l'oeil moulding, but here, as in the other orthostats of the catalogue, the blocks have multiple frames.

⁵¹ Yellow is a common colour for the panels in the upper zone of Second Style decorations (see eg. Heinrich 2002, cat. 14, 33, 34, 84, 93).

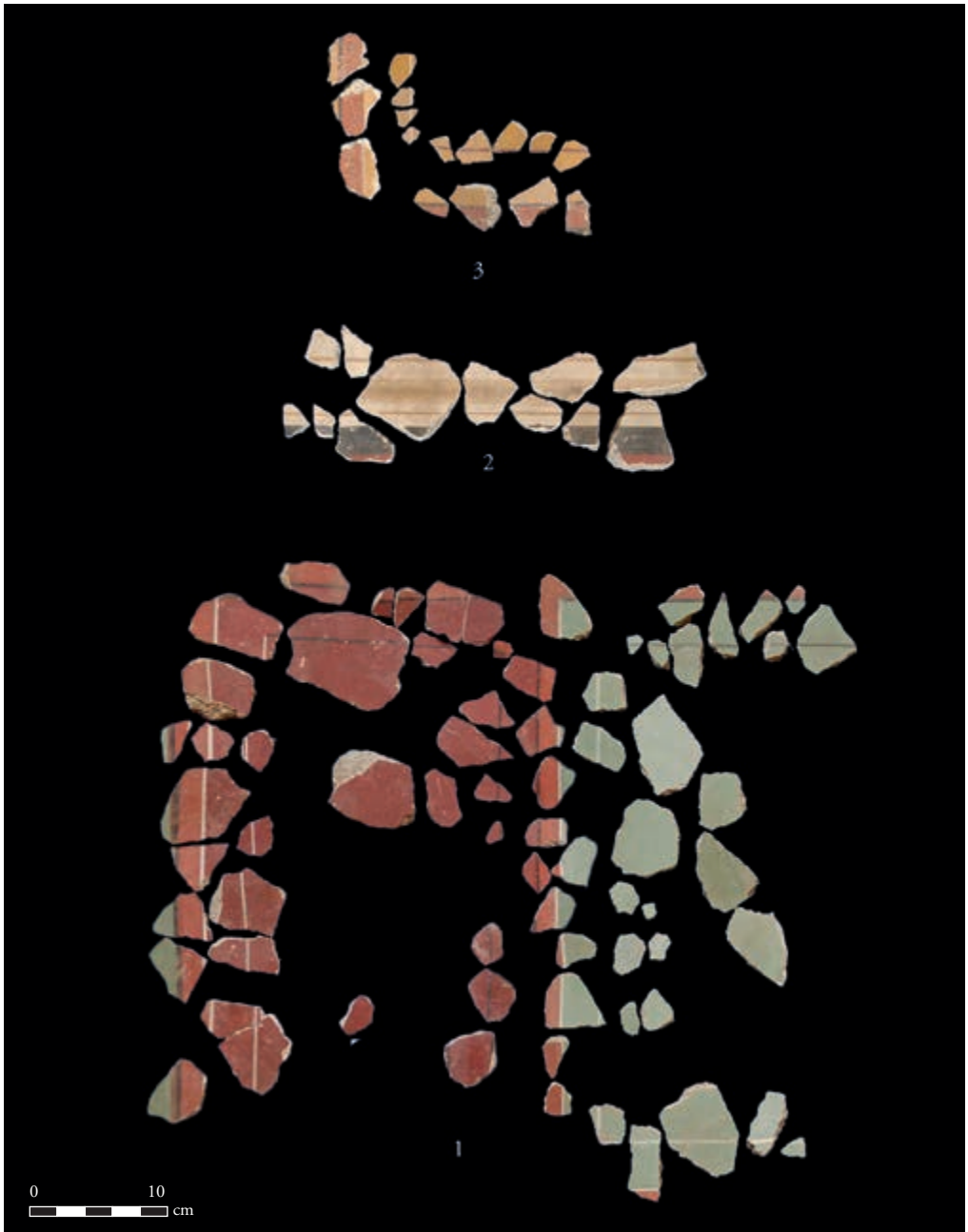

Fig. 4.1-3.

VI.3.5 Fifty-two mostly large, joining fragments assembled in 2007 belong to an actual cyma reversa stucco moulding (Pr. 4.5 cm) and a purple, drafted fascia (H. ca. 18.5 cm). Below, against a black background, is a row of wide oblong, alternately yellow and green panels profiled with white and black or purple lines representing highlight and shadow. The light falls from the right. Below is a trompe l'oeil cyma reversa moulding. Detail 3.5 should have been the crowning part of the decoration in the uppermost part of the wall by the ceiling. The absence of cinnabar in contrast to most of the other details of No. VI.3 might cast doubt whether this detail belongs together with them. However, this could be explained by the location highest on the wall. In some Second Style decorations, a cyma reversa moulding with fascia has been preserved from a previous First Style decoration,⁵² but here no clear junction can be detected between the profiled fascia and the painted panels.

VI.3.6 Dozens of black monochrome fragments. These could belong to the black blocks of detail VI.3.3 or to other black details of the decoration.

VI.4. Trompe l'Oeil Blockwork (Fig. 4.1–3)

Archaeological context: Second atrium (29), trenches CA and CC, pit CF29K1.

Quantity of excavated fragments: over 200 (mostly small).

Colours: Red, green, black, purple, yellow, white.

Plaster: Finishing stucco layer is creamy white and hard with numerous fine yellow crystals, Th. 0.2 cm. The plaster is dark grey, made of fine crushed black stone and sand with inclusions of larger round stones (max. 0.2 × 0.3 cm) and lumps of lime (max 0.5 × 0.5 cm). There might be a second, slightly darker layer with a higher density of crushed stone 0.5 cm below the surface. Easily crumbling and porous.

Parallels: No. VI.3. Various parallels for the individual details (see below).

Dating: 100 BC–62 AD.⁵³

Description and comments: Most of the fragments of this ensemble belong to two kinds of painted two-dimensional panels imitating masonry blockwork. The rest of the fragments show a trompe l'oeil cyma reversa moulding and probably another panel or a set of panels. The pattern and the colours seem to be close to the fragments of Nos. VI.3.2 and VI.3.4, except for the lack of cinnabar, but the execution is much clumsier and the finishing stucco layer considerably thinner.

VI.4.1 Over 200 fragments belong to this pattern that probably consisted of alternating purple and green panels (VI.4.1). Both of the panels are profiled with white and black lines representing highlight and shadow. A brighter red frame (W 1.4–1.7 cm) surrounds and separates the panels. Two fragments show a corner of the purple panel with identical shadowing suggesting that they belong to two different panels. The proportions of the decoration and the fact that only a few corners of panels are preserved in the fragments suggest that the panels were few and large. They might have been part of the orthostats that were alternately purple and green, surrounded by brighter red frames – a scheme similar to No. VI.3.2 and several Pompeian decorations.⁵⁴

⁵² Laidlaw 1985, 42; Heinrich 2002, 25. For stucco mouldings in Second Style decorations, see also Riemenschneider 1986, 26–40.

⁵³ As discussed above, the decoration might have been a later imitation of the Second Style, though this is far from certain.

⁵⁴ See No. VI.3.2 above.

VI.4.2 Fourteen fragments show a trompe l'oeil cyma reversa moulding or mouldings (VI.4.2). One fragment shows a black fillet and a slice of a red field above the moulding. The moulding was probably placed between the socle and the main zone or between the main zone and the upper zone. The surface of the fragments has been heavily worked along the pattern causing tiny straight grooves in the plaster.

VI.4.3 Based on the similarities with the fragments of detail No. VI.4.1, these small fragments probably belonged to yellow panels profiled with white and black lines representing highlight and shadow (VI.4.3). The panels were probably framed by a red fillet. A couple of fragments show two yellow fields (framed by the shadowed lines) on both sides of the red fillet demonstrating that they belonged to a row of yellow panels, possibly in the upper zone of the wall as in No. VI.3.4.

Third Style (Nos. VI.5–6)

VI.5. Ornamental Borders (Fig. 5.1–2)

Archaeological context: garden (18), trenches BC and BD.

Quantity of excavated fragments: 11.

Colours: Yellow, brown, green, black, grey, red, violet.

Plaster: Finishing stucco layer is creamy white and hard with numerous quite coarse yellow crystals, Th. 0.4–0.7 cm. The plaster is made of dark river sand, lumps of lime.

Parallels: For the individual details, see below.

Dating: 20 BC–62 AD.

Description and comments: The ensemble consists of only eleven badly worn fragments that belong to two or three details from probably two different ornamental borders. Five fragments (three joining) show a half yellow, half grey border (W 8.2 cm) on plain white background (VI.5.1). On the yellow part are three lines with red, green and darker yellow and an ornament with grey and brown: a rectangle with two dots framed by two wavy lines that probably symbolize a lotus flower.⁵⁵ The grey part of the border might have been a trompe l'oeil moulding. Five fragments (two joining) belong to another border or the beginning of an ornamental field

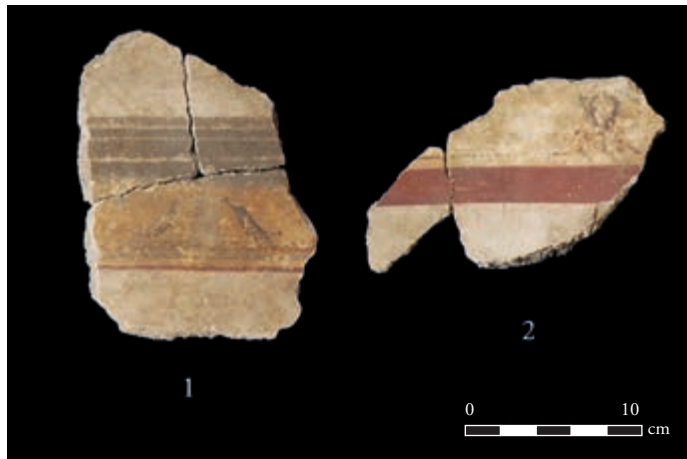

Fig. 5.1–2.

⁵⁵ The two symbols are seen together in a border in Erhardt 1987, pl. 116, fig. 535 and separately in Erhardt 1987, pl. 46, figs. 192, 194; pl. 113, 510. A somewhat similar treatment of the lotus-pattern can be seen in Erhardt 1987, pl. 108, fig. 456; pl. 109, fig. 457; pl. 110, figs. 475, 482.

(VI.5.2.): a red-brown frame divides the plain white background from a yellow field. On the yellow part, a red-brown line sprouts an ornament painted with the same red-brown, greenish grey and pale violet. It probably represents a peacock feather or a palmette.⁵⁶

VI.6. Vegetal Figures, Tongue Pattern, Lines (Fig. 6.1–4)

Archaeological context: room 12, trench BB, pit CF12K1.

Quantity of excavated fragments: over 50.

Colours: Green, brown, yellow, red, pink, black, white.

Plaster: Finishing stucco coat is creamy white and hard with numerous crystals, Th. 0.1–0.4. The plaster is made of fine sand, some lumps of lime. The plaster of the fragment with the plant motif belongs to group F (Third Style) in the typology of Freccero.⁵⁷

Parallels: –

Dating: 20 BC–62 AD.

Description and comments: These fragments belong to at least five details of different colours and pattern. They are treated together because of the similar execution, plaster composition and the plain white background, but do not necessarily belong to the same decoration.

One fragment shows the slender stalk of a plant with green leaves and brown side-shoots. Four small fragments also have vegetal motifs (VI.6.1). The subject would have been suitable for a socle and this could also be suggested by the unusually wide variation of the thickness of the finishing stucco layer in the largest fragment (Th. 0.1–0.4 cm). Eight fragments show two different borders of brown and yellow lines with a tongue pattern in turquoise green and dark red (VI.6.2). One of the fragments also shows a parallel pink line framed by brown lines above the tongue pattern. Eleven fragments show the same pink with brown frames (VI.6.3). It forms a corner in one of the fragments suggesting that decoration had a panelled structure. One large fragment shows a thin



Fig. 6.1–4.

⁵⁶ A very similarly shaped pattern can be seen in a border in Erhardt 1987, pl. 116, fig. 536. It might derive from more elaborate versions like the ones seen in Erhardt 1987, pl. 106, fig. 433 and pl. 108, figs. 454 and 456.

⁵⁷ Freccero 2011, sample no. 8.

turquoise and black line framed by brown lines (VI.6.4). Over 20 fragments show brown lines, one of which is shaded with pale green and white.

Fourth Style (Nos. VI.7–8)

VI.7. Embroidery Borders, Garlands, Borders (Fig. 7.1–6)

Archaeological context: Garden (18), trench BC, pits CF18K2, CF18K3, CF18K4 and CF18K7.

Quantity of excavated fragments: Over 60.

Colours: Purple, yellow, white.

Plaster: Finishing stucco layer is creamy white and hard with numerous large and small crystals, Th. 0.5 cm. In borders 7.4 and 7.5, the surface has been worked along the border leaving parallel scratches and the yellow/white paint seems to include fine sand that makes the finishing less glossy than the purple background. The plaster is made of dark sand and includes some lumps of lime. It belongs to group G (pre-62 AD Fourth Style) in Freccero's typology.⁵⁸

Parallels: Embroidery borders and the purple colour are typical of Fourth Style decorations.⁵⁹

Dating: 45–62 AD.

Description and comments: The fragments show several details on a purple background which probably belong to the same decoration. Twenty-one fragments belong to a yellow embroidery border VI.7.1 (W 4.1 cm) with a double row of arched palmettes with three leaves. A single line runs below them. Seven fragments belong to a yellow embroidery border VI.7.2 (W 3.9 cm) with one row of arched palmettes consisting of two wavy lines and a dot. Between the arches are upside down palmettes of a single wavy line and a dot. The execution is much less precise than in border VI.7.1. Three fragments (two joining) belong to the yellow embroidery border VI.7.3 (W 3.8 cm) with volutes and palmettes. It

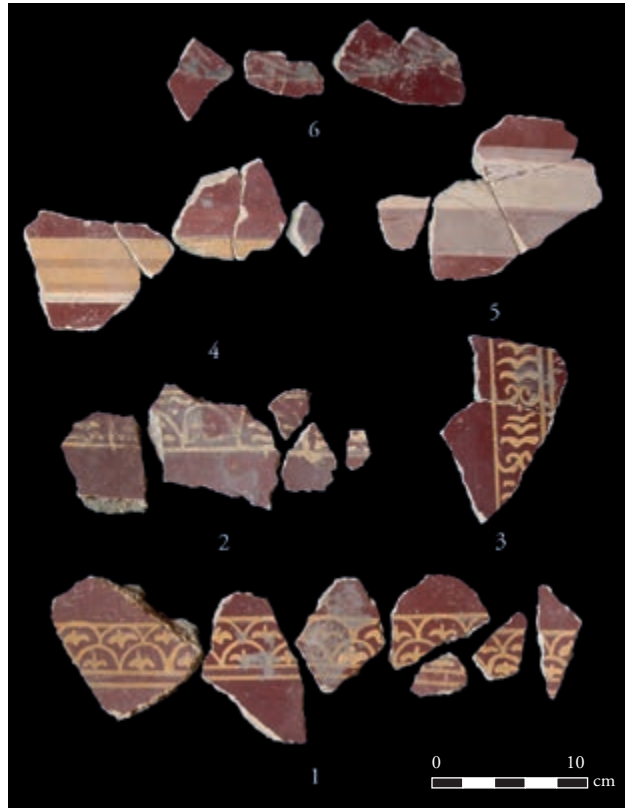

Fig. 7.1–6.

⁵⁸ Freccero 2011, sample no. 12. Group G “probably belongs to the period [...] before the earthquake” (Freccero 2005, 105).

⁵⁹ Ling 1991, 81–84.

is otherwise similar to Ling's (2005) border 73 (536, fig. 171) but the palmettes consist of three wavy lines instead of two. Five partly joining fragments belong to a bright yellow border VI.7.4 (W 4.1 cm). Inside the border are two orange lines and a white line. Five fragments (four joining) belong to a pale grey border VI.7.5 (W 7 cm). The white paint has been applied more intensely on a line in the middle of the border. Five partly joining fragments (VI.7.6) show a gently curving garland painted with black or dark green on a purple background. Yellow details mark fruits or flowers. The garland is drawn with single, relaxed brushstrokes but the paint is quite worn. Numerous completely purple fragments, not included in the catalogue but possibly belonging to the same decoration, were also found in the same context.

VI.8. Ceiling Fragments with Embroidery Borders, Purple and White Fields (Fig. 8.1–2.)

Archaeological context: Garden (18), trench BC, pits CF18K2, CF18K3, CF18K4 and CF18K7.

Quantity of excavated fragments: Ca. 50.

Colours: Yellow, purple, green.

Plaster: Finishing stucco layer is creamy white and has some crystals, Th. 0.2–0.5 cm (large variation within single fragments). The surface is curvy in seven purple fragments suggesting a position in the corner between the wall and the ceiling. The plaster is light grey and made of lime with only some inclusions of stone and lumps of lime. It is very light and porous. All the fragments have the same kind of reed imprints (*cannucciato*) on the background.

Parallels: Embroidery borders on white are typical of Fourth Style ceiling decorations.⁶⁰

Dating: 45–62 AD.

Description and comments: The fragments of this ensemble might have decorated the ceiling of the decoration of No. VI.7. Eighteen fragments belong to an embroidery border painted with yellow on a plain white background (VI.8.1). The fragments are small and worn and the painting is sloppy. It represents a palmettes inside triangles pattern, probably similar to Ling's (2005) border 6 (535, fig. 170). Three small fragments probably have a vegetal motif on a plain white background (VI.8.2). They show a purplish brown stalk surrounded by thinner branches. On two of the fragments there are green spots, probably leaves, on both sides of the stalk. Ca. 30 fragments are completely purple or show a straight borderline between a purple field and a plain white field bordered by a purple line on the white side.

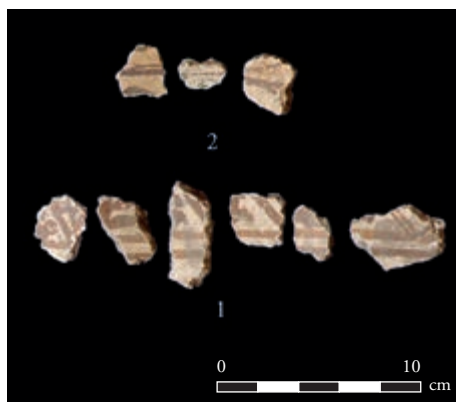

Fig. 8.1–2.

Nebenzimmer Decorations (Nos. VI.9–10)

VI.9. Bands and Stripes (Fig. 9)

Archaeological context: Garden (18), trench BC, pits CF18K2, CF18K3, CF18K4 and CF18K7.

Quantity of excavated fragments: Over 450.

⁶⁰ Ling 1991, 91.

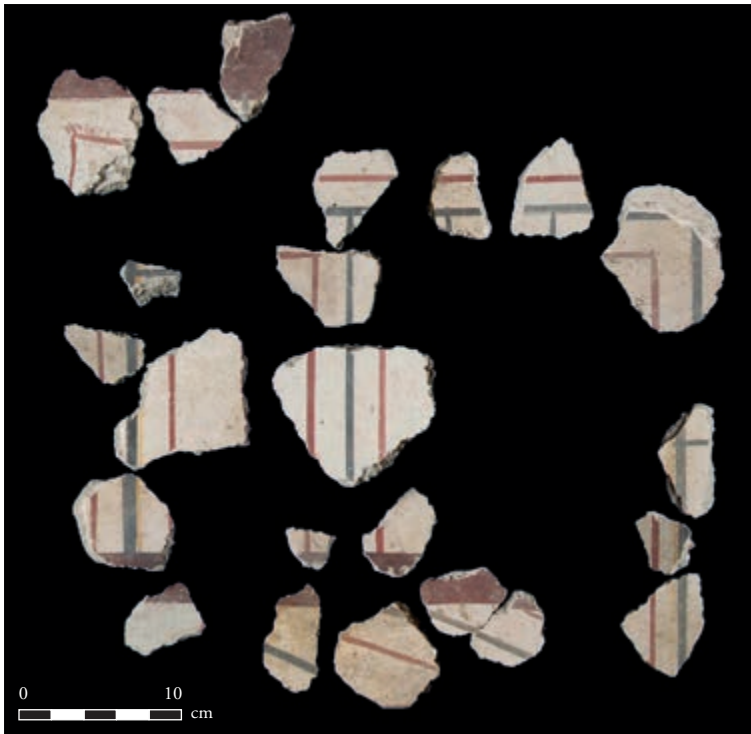

Fig. 9.

Colours: Red, black, brown, yellow.

Plaster: Finishing stucco coat is creamy white with some crystals, Th. 0.2–0.4 cm. The plaster is made of dark sand but the colour is light grey because of its low density. Some inclusions of stones and terracotta and some lumps of lime. In the four last-mentioned fragments the plaster starts to change into ceiling plaster that is lighter (both in weight and colour) and more porous, consisting of lime with some lumps and inclusions of stone.

Parallels: In the “linear-schematisch” variant of the second style, bands and stripes form the outlines of simplistic blockwork.⁶¹ In “Nebenzimmer” decorations of the fourth style a similar scheme of bands and stripes might structure the walls in the manner of the fourth style, as in No. VI.10.⁶²

Dating: 80 BC–62 AD.

⁶¹ Heinrich 2002, 49–53, 64–65, cat. 133–137, 140–148, 150–152. Similar Second Style decorations not in Heinrich: Casa dei Quadretti Teatrali (I 6, 11), *ala* (3) (PPM I, 390, fig. 50); Casa delle Nozze d’Argento (V 2, i) in room (f) (PPM III, 691, fig. 28–29); Casa di Championnet I (VII 2, 1) in room (t) (PPM VIII, 54, fig. 49–51); the House of Augustus on the Palatine in a minor room (Iacopi 2008, 15). Rooms (δ) and (ε), probably used as storerooms in House VIII 2, 36–37, have an interesting decoration of red bands that, according to PPM (PPM VIII, 297–299, fig. 7–14), is a Third Style imitation of a Second Style structure.

⁶² Strocka 1975, 102. Corridor (14) of Casa del Giardino di Ercole (2.8.6) with parallels given by Esposito (2009, 224, pl. CVII.5). *Vestibulum* (47) of Villa di Giulia Felice (2.4.3) (PPM III, 259, fig. 126–128); *cubiculum* (32) of Casa di Meleagro (PPM IV, 812–14, fig. 284–288) and room (δ) of House VIII 2, 39 (PPM VIII, 337, fig. 55–56); room (a) of Bottega di ferramenta (I 6, 3) (PPM I, 279, fig. 1).

Description and comments: One of the largest decorative ensembles excavated in the House of Marcus Lucretius seems to belong to the style with a paratactic scheme of panels framed by red and black bands and stripes on a plain white background, common in the subsidiary rooms from the 1st century BC onwards. Although the best parallels for the pattern in the fragments seem to be found within the Second Style, a later date within the Fourth Style also seems possible.

Of the fragments, almost 300 show a single red line (W 0.2–0.5 cm). Over 50 fragments show a slightly wider black line (W 0.4–0.6 cm). In over 50 fragments, the red and black lines run side by side and several fragments show the black line framed by red lines on both sides. Several fragments show black lines in a T-junction, sometimes framed by red lines on both sides. A few fragments show a black line bordered by a yellow line that probably suggests highlighting. In a couple of fragments the highlighted line meets a perpendicular black line, framed in some fragments by a parallel red line. One fragment shows the highlighted line, framed on both sides by red lines, meeting perpendicularly with a brown field. The brown field, probably a border dividing the wall horizontally in the socle or in the upper zone, is present in several other fragments: in two fragments, a red line or parallel red and black lines meet the brown field; in six partly joining fragments parallel red and black lines meet diagonally with the brown field; one fragment shows the brown field and a parallel red line and in fifteen fragments there is only a straight borderline between a brown field and a plain white field. Five fragments, which, based on the composition of the plaster, belong to the corner between the wall and the ceiling, show a straight borderline between a brown field (towards the ceiling) and a plain white field. In one there is also a sloppy red right angle and in another, a perpendicular black band.

VI.10. Border with Lotuses and Palmettes, Spatters, Bands (Fig. 10)

Archaeological context: Room 12, trench BB, pit CF12K1.

Quantity of excavated fragments: Ca. 300.

Colours: Red, black, white.

Plaster: Finishing stucco layer is red and porous (especially in the spattered fragments) with large amounts of powdered terracotta, Th. 0.2–0.4 cm. The plaster is made of dark sand and belongs to group G (pre-62 AD Fourth Style) in Freccero's typology.⁶³ In the plaster of the spattered fragments there are lumps of lime and larger inclusions of terracotta.

Parallels: Some of the most modest decorations of the so called "workshop of Via di Castricio".⁶⁴

Dating: 45–62 AD.

Description and comments: The fragments belong to a poor-quality decoration probably composed of a spattered socle, a main zone structured by pale red bands possibly imitating *candelabra* and pale black bands drawing the outlines of panels and an upper zone with a border of lotuses and palmettes. The background is plain white (greyish).

Over a hundred fragments show red, black and white spatters on a plain white background divided from a plain white field by a border of black and red lines (W 5–5.5 cm). In one large fragment, a red band (W 1.3 cm) with a black base meets the border perpendicularly on the white side.

⁶³ Freccero 2011, sample no. 9. Group G "probably belongs to the period [...] before the earthquake" (Freccero 2005, 105).

⁶⁴ The *triclinium* (14) of Casa dei Quattro Stili (I 8, 17) (Esposito 2009, 163, pl. LXIX.4); *cubiculum* 5 of Casa della Venere in Bikini (I 11, 6–7) (Esposito 2009, 180, pl. LXXX.1.) lacks the *candelabra* but the lotuses and palmettes frieze is similarly simplified; the *triclinium* (6) of Casa I 16,3 (Esposito 2009, 207, pl. CII.1, CII.4) does not have spatters in the socle but the division of the wall is probably similar. For the "workshop of Via di Castricio" see also De Vos 1981, 119–30.

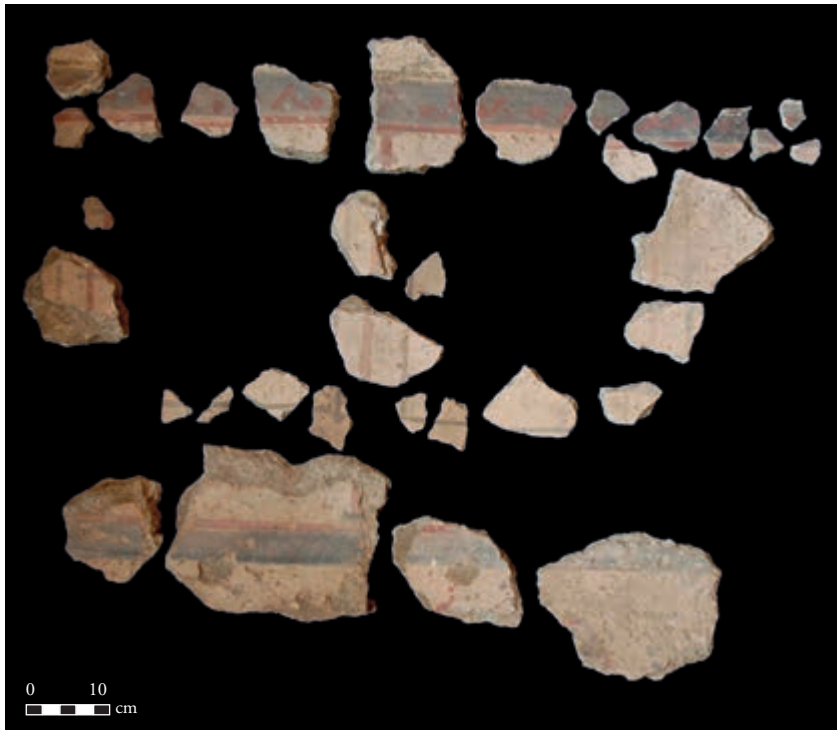

Fig. 10.

This is probably the base of a simplified *candelabrum* consisting of a red band with occasional short crossing black lines. A similar red band can be seen in over 40 fragments. In thirteen fragments, it is framed on both sides by parallel black lines (W 0.5–1.0 cm). Over 40 fragments show only a black line while two fragments show black right angles with a small knot in the corner. Almost 50 fragments show an ornamental border that probably crowned the main zone. The border has an almost unrecognizably careless lotuses and palmettes frieze painted with red on top of a black background. Below the border runs a red line shadowed with diagonal dots. One large fragment shows the top of a *candelabrum* – a red line and a short crossing black line – meeting the border. The upper edge of the border terminates in a groove and the surface of the plaster becomes spongy with a yellowish covering – probably what is left of a cornice or some kind of a joint between the wall and the ceiling.

Garden Paintings (No. 11)

VI.11. Vegetal Motifs, *Incannucciata* Trellis Fence, Bird (?), *Candelabrum* (?) (Fig. 11)

Archaeological context: Atrium (2), trench AA, pit CF2F.

Quantity of excavated fragments: Over 200.

Colours: Blue, yellow, green, purple, black, grey, white.

Plaster: Finishing stucco layer is red with large amounts of finely crushed terracotta, Th. 0.3 cm.

The plaster is made of dark sand and belongs to group G (pre-62 AD Fourth Style) in Freccero's typology (she considers it "the same" as the plaster of No. VI.10).⁶⁵

Parallels: The garden (8) of Casa della Venere in conchiglia (II 3, 3) shows an identical *incannucciata* trellis fence and a similar alternately blue and yellow background. Two Pompeian garden view decorations show similar *incannucciata* trellis fences, though the other one has a double grid.⁶⁶ In two decorations the background of the garden view is yellow, but there is no fence,⁶⁷ while in two decorations the background is blue and there is a fence (more elaborate in the other).⁶⁸ In a couple of similar decorations the background of the garden view is white.⁶⁹

Dating: 45–62 AD.

Description and comments: The fragments belong to a decoration (or decorations) with garden views that probably decorated an outdoor *viridarium*. A yellow *incannucciata* trellis fence on black background probably decorated the socle. Vegetation painted mainly with green but also with yellow and purple decorated the main zone. The background colour behind the vegetation is black (probably behind the dense vegetation above the fence) and blue or yellow – the last two probably alternately on different walls.⁷⁰

Dozens of fragments show a yellow *incannucciata* trellis pattern on black background with a green ivy leaf in every diamond-shaped opening of the *incannucciata*. Dozens of fragments show vegetation painted with different shades of green and grey with yellow details on black background. In one of the fragments there is also a yellow and white flower. Several fragments show the background colour shifting from black, mixed with the green of the vegetation, to light blue. Many fragments show dark green (green on black) vegetation against a light blue background. Dozens of fragments are completely light blue. A few fragments show a white band that divides a blue field from a black field. One fragment shows a white band on black background with green vegetation. These lines might have been framing the garden view on the sides. Several fragments show green, black and purple vegetation with white details on a yellow background. Dozens of fragments are completely yellow. One fragment shows part of a white and pale purple border on a yellow background. Besides the vegetation and the *incannucciata* trellis pattern, the figurative elements are few and fragmentary and mostly on the yellow background: a few fragments show parts of an unrecognizable object in yellow and beige on a light blue background; a few fragments have pale purple, white and beige brush strokes on a yellow background (feathers of a bird?); one fragment has a round purple shape with white dots on yellow (the crown of a bird?); two fragments have a round purple shape with details in white on yellow (the back and/or chest of a bird?); a few fragments show parts of what is probably a *candelabrum* with pale purple on yellow background.

⁶⁵ Freccero 2011, samples no. 10 and 11. Group G "probably belongs to the period [...] before the earthquake" (Freccero 2005, 105).

⁶⁶ VII 2, 44–46 garden (m) (PPM VI 780–781); II 9, 5.7 garden (1) (PPM III 330–336).

⁶⁷ I 7, 2.3 *viridarium* (g) (PPM I, 568); I 12, 8 peristyle (9) (PPM II 767–769).

⁶⁸ I 17, 4 peristyle (1) (PPM II 1042–1046); VII 2, 44–46 garden (m) (PPM VI 780–781).

⁶⁹ Part of II 9, 5.7 garden (1) (PPM III 330–336); VII 3, 30 (k) (PPM VI 968–973).

⁷⁰ See the parallel decoration in the garden (8) of Casa della Venere in conchiglia (II 3, 3).



Fig. 11.

VII Masks

LEENA PIETILÄ-CASTRÉN

Masks were common motifs in architectural decoration, they appeared both as isolated decorative elements in a room, antefixes or elements of friezes, and as groups hung in the intercolumniations of a peristyle.¹ They were used as *oscilla* and *apotropaia* in contexts ranging from tragedy to farce.² In themselves, the masks could be connected to a household's interest in theatre and Bacchic symbols.³ A new koine of types, and indeed the whole art of masks, began in the early third century BC, continuing throughout the Hellenistic and Imperial periods.⁴

Two fragmentary masks were discovered in the course of the work done by EPUH in the early 2000s. The first was discovered in the premises of the house itself and the other elsewhere in the Marco-Lucretian insula.

Catalogue

VII.1 Mask (Fig. 1)

BD 18.81.110.

Place of discovery: Viridarium (18), trench BD.

Dimensions: pH 5.9; pW 3.3. Th. 0.2 cm.

Technique: Molded, tooling on details, flat back.

Clay: Pink (7.5 YR 7/3), inside pinkish-gray (5 YR 6/2).

Decoration: Light bluish-gray (Gley 2 8/1) slip.

Condition: Fragment. Nose and part of left eye preserved. Brown incrustation especially on the left side.

Bibliography: Berg 2008, 159–160, fig. 12.11.

Description: The eye slants downwards, with clearly marked eyelids and pierced pupil. The nose is thin and straight, slightly hooked.

Comments: So little survives of this mask that it is difficult to attempt to characterize it. Only its colour and a general impression



Fig. 1.

¹ They sometimes progressed to become part of the painted wall decorations, as shown, *e.g.* in the garden rooms of La Casa del Bracciale d'oro in Pompeii (VI, 17, 42), see *Life and Death* 172–174, and also as reconstructed in La Casa degli Amorini Dorati (VI 16,7.38), see Fejfer 2008, 92, fig. 5a.

² Grandjouan 1961, 22. Dwyer 1981, 250: decorative terracotta masks far outnumber those made of marble in Pompeii. About the term *oscillum*, Bacchetta 2006, 27–31.

³ Verg. *Georg.* 2.388–389: *et te, Bacche, uocant per carmina laeta, tibi quae oscilla ex alta suspendunt mollia pinu.* Dwyer 1981, 257–258, 302–303; “Maschere ornamentali”, 131.

⁴ On the third-century BC examples from Lipari, Bernabò Brea 2001, 147–150, figs. 201–203, and from late third and early second century BC Rome, Pensabene – Sanzi Di Mino 1983, 107, nos. 159–161, pls. 39–40; no. 168, pl. 40.



Fig. 2.

of the features remain. The appearance of the nose is rather masculine,⁵ the pale complexion and slanting eye(s) create a sorrowful expression, making our mask rather more likely to be part of the tragic repertoire.⁶ In the same trench (BD) of the garden of Marcus Lucretius, where this mask fragment was discovered, fragments of Third Style wall paintings were also found, thus potentially dating our example to the Julio-Claudian period.⁷ It would be tempting to think that the material originates from the site, making the terracotta mask an element of the garden decoration preceding the later marble oscilla.⁸

VII.2 Male Head (Fig. 2)

DC 136.1.1.

Place of discovery: Atrium of the House 25.

Dimensions: pH 13.6; pW 11.4.

Technique: One-piece mould; hollow at the back, hand-smoothed.

Clay: Pinkish-white (2.5 YR 8/2) with black inclusions.

Decoration: The colours were applied directly onto the clay.⁹ The cap is light red (10YR 7/6), bright-

⁵ Cf. Webster 1995, 16–17, 21 and nos. 10, 11 and 15.

⁶ Cf. Bernabò Brea 2001, 155.

⁷ Hakanen 212–214. On the chronology of (marble) oscilla, Dwyer 1981, 256–257, and Bacchetta 2006, 63–67.

⁸ Kuivalainen 104–109.

⁹ It was more usual to apply the colours onto a white-slipped base, Bernabò Brea 2001, 275.

er red (10R 4/6) under the tip. Hair, eyelashes, brows, and pupils are painted with black (7.5YR 2.5/1). Complexion is reddish-brown (2.5YR 5/3).

Condition: Fragmentary. Upper part of the face is preserved, with both eyes and part of the left cheekbone. Broken on top of head.

Bibliography: Berg et al. 2008, 204, 209, fig. 19.1.

Description: He has incised eyes, almond-shaped and smallish, framed by clearly marked, arching eyebrows. The tight, small curls frame the face along the forehead and temples. He wears a conical Phrygian cap with tip slightly askew towards right.

Comments: The object's size and appearance allow it to be identified as a mask. The youthful man wearing a Phrygian cap is a *pilleatus*. The choice of candidates for well-known *pilleati* is vast, ranging from Alexander-Paris, Attis, the Dioscuri, Ganymede, Hector, Mithras, Orpheus, to Perseus, and others.¹⁰ From this list we might pick Attis as an appealing alternative in view of his wide acceptance, along with Cybele, among the divinities at Pompeii, as shown by his many representations on bronze vases, terracotta statuettes, and wall paintings. Their cult of orgiastic character was intimately connected to the worship of Bacchus, and thus also with the theatre and the mysteries.¹¹ Whom our head did represent was once indicated by his other attributes. Without them, it remains a generic mask with an eastern flavour,¹² originally performing both a decorative and a religious function. Most probably an *antefix*, it must have belonged to an earlier phase of a well-off house in the *insula*, but was later hidden in a pit in the atrium of House 25. Its decorative aspect was certainly lost, and it became instead an obscure object in a votive deposit.¹³

Concluding remarks

The fragmentary mask (No. 1) seems to have belonged to an earlier phase of the site. It would make the terracotta mask an element of perhaps suspended decoration, preceding thus the later marble *oscilla*. The male head (No. 2) with oriental cap was discovered in secondary use in a pit. Whether it originally decorated the walls of the small House 25 or came from one of the *insula*'s more affluent houses remains unknown. The two masks belonged essentially to the Bacchic world and the theatre.

¹⁰ Grandjouan 1961, 14; Vermaseren 1966, 54.

¹¹ Tran Tam Tinh 1975, 279–281; Vermaseren 1977, 64. For late Hellenistic terracotta heads identified as Attis, d'Ambrosio 1990, 68–69, pl. 26, figs. 165–167.

¹² Bernabò Brea 2001, 40–41, fig. 13; 281; see also the masks 246–247, 256–258, nos. 341–344, 356–360. Another terracotta mask with a conical hat with tip from a Pompeian tomb: von Rohden 1880, XII, 21, fig. 14.

¹³ A. Comella, *s.v.* Deposito votivo, *ThesCRA* 4 (2005) 227, and on votive heads, A. Comella *s.v.* Teste, *ThesCRA* 2 (2004) 335–336.

CONCLUSIONS

The works of art, inscriptions, and other finds from the House of Marcus Lucretius have been documented many times before this publication, but never as completely as in this first volume by the *Expeditio Pompeiana Universitatis Helsingiensis*. A major issue has been that most of the finds have been lost over time, notably the small instruments and utensils, and only twelve percent have now been rediscovered. In addition to the up-to-date publication of these rediscovered items, this volume importantly endeavours to reconstruct, quantify, and analyse the objects that are still unlocated. In the early documentation some finds, mostly terracotta vases, were completely ignored, and not even mentioned in the excavation reports, or reported only vaguely with no useful details. Considering the time period, however, the finds from the house were recorded exceptionally well. Several inventories and lists were compiled and published in the years immediately after the excavation by Bernardo Quaranta, Giulio Minervini, and Edward Falkener. For the researchers of this house, by far the most important source has been Edward Falkener's original report of the excavation.

In the process of rediscovering the material, retracing their removal from their place of discovery to their new storage location was of the utmost importance, as they had often lost their provenience en route to the Archaeological Museum of Naples, and even while still in Pompeii. The irregular system of registration also turned out to be problematic, as it had been customary to change inventory numbers while changing displays in the museum, and much information was lost through these changes. Thus, important data, originally meticulously collected and recorded, were gradually lost during these critical moments of the archival *iter* of the objects.

Exceptionally for the House of Marcus Lucretius, the decision to leave some of the flawless marble statues in situ in the garden was made soon after excavation, while the fragmentary statues were sent to the storerooms of Pompeii and Naples in the hope of guaranteeing their survival. Marcus Lucretius' garden is indeed an iconic example of a Pompeian garden decorated with statues; there was an aedicula with a fountain and water stairs, and several statues with an overall Bacchic theme. The garden was remarkable for the theatrical display and richness of its decorations in comparison with its small area. It thus became an important sight in Pompeii, and a selection of the statues were studied in detail in consecutive publications. At the same time, however, their open display made them vulnerable; some were stolen, even in several stages, and others' condition deteriorated due to weathering.

Among the inscriptions, the most famous – containing the name of the eponymous M. Lucretius – is now in Naples, but another famous graffito depicting a labyrinth, also removed, can no longer be located. The names of some 19th century visitors inscribed on the walls are testimonials to the importance of the house for tourists and scholars alike. They primarily came to see the statues, as part of the wall paintings had been relocated in the museum.

The assemblage of the figurines and statuettes of terracotta is somewhat heterogeneous, ranging from Late Classical and Hellenistic iconography to characteristically Roman themes. The earlier types are seen in the female figurines and the Bacchic elements, while the Roman subjects appear as a genre selection and in portraiture. Figurines of gilded clay are the nearest we have to figurines made of metal, as the main lararium of the house was devoid of material when discovered. The figurine set recovered mostly from the servile quarters, and thus perhaps from a lararium maintained by servants, is thus the only representative of that type from the house. An Egyptian flavour among the more luxurious items is represented by a glazed Bes figurine.

The ensemble of all the finds from the house, originally comprising ca. 500 objects, has been analysed both quantitatively and spatially. The distribution patterns of the finds throughout the house reveal only a few specific activity-related clusters, in particular a number of food processing utensils in the kitchen area, a large medical set in cubiculum R5, and a small female toiletry set in cubiculum R34. For the most part, the distribution patterns are related to the storage, rather than the use, of the objects. Thus, the two atria R2 and R29 figure as important centres of domestic storage, both provided with cupboards. The general distribution pattern of the finds shows the heaviest concentration was in the small closable rooms flanking the main entranceway of the house, and the main storage area of the house was probably the cubiculum R4. In contrast, the most prestigious rooms reserved for status display, banqueting, and the reception of guests (alae R8-9, tablinum R15, triclinium R16) were found practically empty of loose finds. These characteristics fit well the general pattern of Pompeian houses.

A comparison of the quantities of objects found in the house with other houses can give a rough estimate of its relative richness, albeit as affected by the tumultuous deposition process and possible plundering. In particular, considering the total number of all finds and the amount of bronze wares, the House of Marcus Lucretius can be ranked high among Pompeian households, closely following the House of Menander, which was undoubtedly one the very richest of the city.

The analysis of the located objects has highlighted the exceptionally high quality of the material finds from the house. The bronze ware notably included large twin amphorae decorated with Dioysiac imagery, as well as other relief decorated vessels. A drinking service was made of very precious transparent, colourless, mould-cast and incised glass, including pairs of jugs, cups, *mensula*-bases, and probably also chalices. The service is morphologically, and possibly even economically, comparable to similar sets of silver table ware, *argentum pоторium*. The doubling of the items enhanced the prestige of the set, echoing symmetry as an important status symbol both in Roman architecture and in domestic furnishings. The medical set found in cubiculum R5, of the size of a portable kit rather than a large and complete set of office tools, suggests that a professional doctor, capable of surgical operations, may have been a member of the household. The bronze bracelet with a head of Sol, possibly a military insignia, might reflect the possible military interests of M. Lucretius, a *flamen* priest of Mars, as might also the glass disc decorated with a Medusa

head, similar to military phalerae. Weapons and shields with Medusa heads also decorated the walls of the house. In general, the numerous and widely distributed finds, in particular the numerous cauldrons for boiling water and other kitchen utensils in the servile quarters, as well as the agricultural tools, are suggestive of lively and continuing activities in the kitchen, garden, and perhaps also in vineyards outside of the town, likely belonging to the owner of the house. However, the carpenter's tools, as well as a lime heap and loose column capitals, rather testify to ongoing renovation work in the house, which must have strongly disturbed, if not interrupted, its daily routines.

This volume also presents the first group of finds, the masks and fragments of wall paintings coming from the excavations by the EPUH team. The latest field work revealed a fragmentary mask, probably from an earlier phase of the garden decoration; another fragmentary mask was discovered from an evidently new context in a pit in House 25, in the same insula. Eleven decorative ensembles of wall paintings were identified among the newly discovered decorated wall plaster fragments of the House of Marcus Lucretius. Some of them consisted of several hundred fragments, others of only a dozen. The finest ensembles in terms of the quality of plaster, colours, and execution belong to the First and Second Styles, while those datable to the First Century AD are modest in comparison. The various painting styles could represent the situation before 62 AD, when the area that would later become a single house was probably a somewhat eclectic collection of three or more earlier houses. However, as even the largest of the identified ensembles represents only a fraction of the original decorative scheme, it is difficult to verify whether they actually derive from the area of this later house.

M. Lucretius, confirmed as the probable proprietor of the house by the painted letter addressed to him, was a civic official in the rare role of *flamen Martis*, and thus belonged to the *ordo* of the city decurions. As revealed by the graffiti, he may have even had some contacts and received favours from the Imperial family. His large house, of 555 m², was magnificently decorated by paintings, sculptures, and furniture, all revealing a pervasive interest in Bacchic themes.

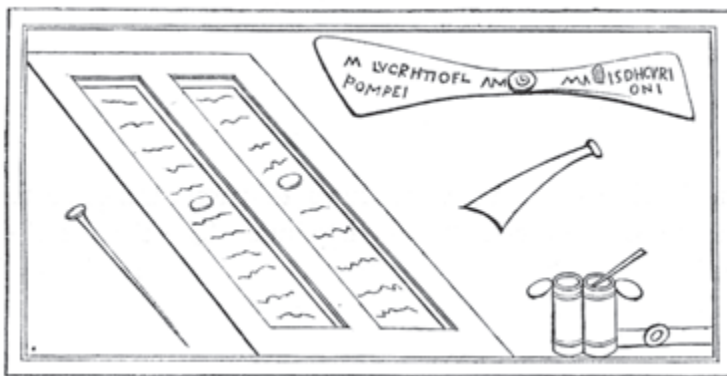

Painted letter with the name of M. Lucretius. Falkener 1852, 72.

Appendix 1

CATALOGUE OF FINDS FROM THE EXCAVATIONS OF 1847 BY ROOM

RIA BERG

Appendix 1 lists all finds mentioned in the main excavation reports, i.e. the *PAH*, Falkener (1852), and Minervini (1854, 1855). The finds are ordered primarily by room and, inside the room, progressively by excavation date. The finds are primarily assigned to rooms following the attributions made by Falkener. In the beginning each chapter there is a short discussion about the developing differences, contradictions, and uncertainties that arose between the sources in attributing single finds to a particular room. The finds that Falkener does not mention, but which are mentioned in the *PAH*, are listed in the room that was excavated that same day, cross-referencing the evidence with Falkener's. Their find-spots therefore remain hypothetical. The finds for which no location can be proposed are listed separately at the end of the catalogue. As for the finds' current locations, most items have been entered in the collections of the Naples Archaeological Museum (MANN) and were registered upon arrival in the *Registro Immissione* (*Reg. Imm.*) on two different convoys in 1847. Some can be identified in the *Inventario Sangiorgio* (*SG*) and traced through to the current MANN Inventory, *Inventario Fiorelli*, which often provide additional information on otherwise missing objects in their descriptions. When an object, with or without a current inventory number, was not physically found in the museum storage rooms (mostly because the inventory tag had been detached), it is designated as 'not located'. The measurements (in cm), modern bibliographies, and morphological data are here provided and discussed only for the objects that are known solely from archival sources, and are therefore do not appear elsewhere in the book as separate catalogue entries.

The objects that have been located in Pompeii or the MANN and were studied and published in this book have their individual catalogue numbers in their heading. For these objects, only the contemporary publications in the *PAH*, Falkener, Minervini, Panofka, or Breton are listed here, with references to their inventorial journey at the MANN, whereas the complete bibliography, documentation, and typological discussion can be found in the catalogue entries of the respective individual chapters.

The 'functional category' gives the classification of the object on which the quantitative data are based: first, the primary morphological/functional category (architectonic, object of art/plastic figure, fixture, instrument, vessel); and second, when possible, the specific function (closure, cooking, lighting, medical/cosmetic, storage, writing, weighing etc).

To set the finds in their architectural context, a short description of each room can be found in Appendix 2.

R1 FAUCES

Although the excavation began with the entrance fauces (prothyrum, andron)¹ the reports slightly disagree about the exact date. According to the weekly reports of G. Cirillo, the work started on March 15, but the *Annali Civili* (p. 72) records the first finds on March 17 – without, however, specifying the house: “A man sinistra del quadrivio che mena a teatri”. *PAH* II, 459, records the same finds in March 18, referring to the excavation of the ‘cortile’, i.e. atrium R2: “Si è travagliato nella casa delle Sonatrici, ove si principiano a pale-sare nelle pareti del cortile delle bellissime dipinture.” This means that the fauces, decorated with paintings on a blue background, including a central image interpreted as depicting musicians, ‘sonatrici’, must have been uncovered by then as well.

Seven objects are listed by Falkener as found in the *prothyrum* (Cat. 1–7). According to him, they derived from the first floor (“it is clear that these objects must have fallen from the upper floors”) and would thus not form a floor assemblage belonging to this room. Breton enumerated seven finds from the prothyrum, as well, following Falkener’s list.² The *PAH* lists these seven and two additional items (bronze hinge, Cat. 8; bone spatula, Cat. 9) as the first finds from the House of Marcus Lucretius, made on March 18, 1847. It seems likely that these two extra items already belonged to the area of the atrium R2, and here they have been listed among the atrium finds. None of these finds have been located in the MANN.

March 18

1 Terracotta vessel

AC IV, 72, “un picciolo vasettino di color rosso, col buco nel centro”; *PAH* II, 459, “un piccolo vasettino con buco nel centro, di color rosso forse conserva di monete”; Falkener 1852, 42, n., “a small vase for ointment”. *Present location*: MANN *Reg. Im.* 22.7.1847, “un vasettino con buco nel centro forse per conservare monete”. Not located. *Comments*: The interpretation of the object differs in the account of the *PAH* (money-box) and Falkener (*unguentarium*). The red colour may indicate that this was a *terra sigillata* vase. However, Minervini (1854) counts three ‘salvadanai’ from the house, not two, thus probably including this one. He, however, describes it wrongly as having ‘forma di cassetino’, as does the other money-box that is still preserved. The confusion of Falkener with an *unguentarium* would better be explained by a vase with a globular form and a hole at the top, which might even be a *terra sigillata* ink-stand. *Functional category*: Vessel, writing? (ink-well) or economic? (money-box).

2 Terracotta cup

AC IV, 72 = *PAH* II, 459, “una tazzolina circolare di color rosso”; Falkener 1852, 42, n., “two small cups”, see below. *Present location*: MANN *Reg. Im.* 22.7.1847. Possibly *SG, Vetri antichi*, 5243, “tazzolina circolare di color rosso, diametro circa due once e mezzo”. Not located. *Functional category*: Vessel, culinary consumption. Probably a small terra sigillata cup.

3 Terracotta cup

AC IV 72, “una picciola coppa”; *PAH* II, 459, “una piccola coppa”; Falkener 1852, 42, n., see above. *Present location*: MANN *Reg. Im.* 22.7.1847, “piccola coppa”. Not located. *Functional category*: Vessel, culinary consumption.

¹ *PAH* II, 459; Panofka 1847 a, 130; Avellino 1848, 1–2; Pancaldi 1848, 6; Falkener 1852, 39–42; Minervini 1854, 73; 1855, 52–53; Breton 1855, 298–299; Overbeck – Mau 1884, 315; Dwyer 1982, 19; *PPM* IX, II, 144–150; Tammisto – Kuivalainen 2008, 85.

² Breton 1870, 396.

4 Bronze handle

AC IV, 72, “un piccolo manico di vase”; PAH II, 459 “un piccolo manico di vaso”; Falkener 1852, 42, n., “small handle of vase”. *Present location*: MANN *Reg. Im.* 22.7.1847, SG signed at the margin. SG 8285, *Bronzi minuti*, “un piccolo manico di vaso di bronzo con maschera giovanile e foglia, lungo once tre e mezza”. Not located. *Dimensions*: L 7.7. *Comments*: Vase handle, terminating with decorative appliques, head of youth and leaf. Could derive from a bronze amphora or pitcher, cf. Tassinari groups amphora A, and pitchers B and D, with a relief mask at lower juncture of the handle, and a leaf pattern on the exterior surface of the handle. *Functional category*: Vessel, pouring (tableware).

5 A wing of a bronze strap hinge

AC IV, 72, “mezzo arpione”; PAH II, 459, “una mezza scibba”; Falkener 1852, 42, n., “half a hinge”. *Present location*: MANN *Reg. Im.* 22.7.1847, “una mezza scibba”. Not located. *Functional category*: Fixture, closure (door).

6 Bronze lock

AC IV, 72, “una serratura con lucchetto”; PAH II, 459, “una serratura col suo lucchetto”; Falkener 1852, 42, n., “a lock”. *Present location*: MANN *Reg. Im.* 22.7.1847. Not located. *Functional category*: Fixture, closure.

7 Glass bottle

AC IV, 72 “una caraffinetta rotta”; PAH II, 459, “una caraffinetta rotta”; Falkener 1852, 42, n., “a glass cup”. *Present location*: MANN *Reg. Im.* 22.7.1847, “una caraffinetta di vetro”. Not located. *Comments*: The description of PAH and Falkener differ somewhat, the word ‘caraffinetta’ being normally used for closed vessels such as bottles, whereas Falkener uses the word ‘cup’, referring to an open form. *Functional category*: Vessel, medical/cosmetic.

R2 ATRIUM

The large and lavishly decorated atrium, stripped in Antiquity of its marble *impluvium*, was excavated on various days: March 18, 23, 29, and April 6–8, 10, 20, and 22.³ Falkener (1852, p. 45, n.) provides a list of 29 objects found in the atrium area, including a group of nails of unknown number. In the PAH, however, no finds are specifically attributed as coming from the atrium. The atrium paintings are mentioned for the first time on March 18, and the two first finds (Cat. 8–9) that may come from the frontal atrium area appear on this date among the finds from the fauces R1. The PAH recorded the first finds that are also located by Falkener in the atrium on March 23: a *candelabrum* foot and base (Cat. 10–11). However, according to the PAH, on the same and following day (March 23 and 24), the *cella ostiaria* R3 and two first lateral cubacula, R4 to the right and R6 to the left, were also unearthed, and their finds were listed together. Four of the items listed in the PAH as being uncovered during those two days are not mentioned at all by Falkener, and thus are not specified here as coming from any of these rooms (terracotta base, Cat. 12; marble plates, Cat. 14; glass cups with pedestals, Cat. 61). They may in fact belong to the atrium area – and, while their exact provenience remains uncertain, they are included here in the atrium finds, with the exception of the glass cups, which may be associated with the ‘two very small vases’ of Falkener, taking into account the omission of their pedestals. The largest group of atrium finds mentioned by Falkener were made on March 29, when the PAH lists 13 items that coincide with Falkener’s information (Cat. 15–17; 19). On the same day, fragments of gilded stucco (Cat. 18), a fragmentary marble statue (Cat. 13), and fragmentary marble plates (Cat. 14) were found, according to Falkener ‘in front of tablinum’, indicating that by this date the area of the atrium was mostly empty. In fact, the tablinum contents began to appear on March 31. Two further atrium finds are listed in PAH for April 8 (Cat. 20–21). According

³ PAH II, 459; Panofka 1847 a, 130–131; Avellino 1848, 3; Bechi 1852, 3; Falkener 1852, 42–45; Minervini 1854, 3–4; Breton 1855, 299; Overbeck – Mau 1884, 314–315; Dwyer 1982, 20. 24–25; PPM IX, 152–157; Tammisto – Kuivalainen 2008, 85.

to the weekly reports of Cirillo, by April 10 the cubacula had been excavated, and work was under way on the tablinum and alae. Falkener also mentions a human cranium among the atrium finds (Cat. 24), found on April 20. It is likely that the rest of the finds mentioned in *PAH* that day – apart from the silver sheath (Cat. 123), four iron nails (Cat. 22), and gilded stucco fragments (Cat. 23) – also derive from the SE corner of the atrium, but might also belong to R5. A further small group of finds on April 22 (Cat. 25–27) can be identified with the atrium finds mentioned by Falkener.

The finds that probably came from the upper floors above and around atrium are separated in this Catalogue. The *PAH* states that they derive from upper strata, ‘dall’alto delle terre’, like the finds made on April 6, when six objects collocated by Falkener in the atrium appeared (Cat. 28–29; 32–34). On the same day, a bronze nail (Cat. 30) and a bone implement (Cat. 31), not mentioned by Falkener, were also listed, and have been included here in the same group, although their provenience remains uncertain.

As stated above, a bronze hinge and a bone spatula (Cat. 8–9), found already on March 18, might also belong to the atrium finds. As for hinges, Falkener lists three folding door hinges and three door hinges as coming from the atrium. The *PAH* enumerates in total only five different hinges from the days that the atrium was excavated: ‘scibba a meccione’ on March 18, ‘scibba di porta’ on April 6, ‘scibba a meccione’ and ‘altra, per lo stante’ on April 22, and ‘sciba a meccione’ on April 22.

Breton mentions among the atrium finds only, and erroneously, includes the Lares in bronze.⁴

March 18

8 Fragment of bone spatula

According to *AC* IV, 72, “un frammento di stecca” found already on 17 March, with items coming from the fauces R1; *PAH* II, 459, “un frammento di stecca”. *Present location*: MANN *Reg. Im.* 22.7.1847, “frammento di stecca”. Not located. *Comments*: Missing in Falkener 1852. The *AC* and *PAH* are in conflict, and the items might also come from R1. *Functional category*: Instrument, medical/cosmetic.

9 Bronze strap hinge

According to *AC* IV, 72, “un arpione da porta” was found already on 17 March, with items coming from the fauces R1; *PAH* II, 459, “una scibba per lo stante”. *Present location*: MANN *Reg. Im.* 22.7.1847. Not located. *Comments*: Probably among the group of three folding-door hinges mentioned by Falkener among the finds of the atrium, Cat. 33–34. *Functional category*: Fixture, closure (door).

March 23

10 Bronze candelabrum foot

PAH II, 460, “un piede di candelabro”, Falkener 1852 45, n., “bases of two candelabra”, see below; Dwyer 1982, 25, iii. *Present location*: MANN *Reg. Im.* 22.7.1847. Not located. *Comments*: The *PAH* mentions, separately, a candelabrum foot and the base of the foot of a candelabrum, whereas Falkener speaks only of bases for two candelabra. From the description in the *PAH* it could be deduced that the first fragment found was one of three protruding, arched feet, normally ending in a feline paw. See below. *Functional category*: Instrument, lighting.

11 Bronze candelabrum base

PAH II, 460, “una basetta di piede di candelabro”; Falkener 1852 45, n., “bases of two candelabra”, see above; Dwyer 1982, 25, iii. *Present location*: MANN *Reg. Im.* 22.7.1847. Not located. *Comments*: The expression ‘basetta di piede’, corresponds to the small circular, moulded base soldered under the feline paw of some candelabra, cf. *Rediscovering*, 213–214, cat. 103. The Cat. 10 and 11 would thus form together one foot of a candelabrum. *Functional category*: Instrument, lighting.

⁴ Breton 1870, 388.

12 Terracotta base

PAH II, 460, “una piccola basetta circolare”. *Present location*: MANN *Reg. Im.* 22.7.1847, “piccola basetta”. In *Reg. imm.* this is listed as a bone object. Not located. *Comments*: Not mentioned by Falkener. Base of a large terracotta vessel, altar or *thymiaterion*? *Functional category*: Vessel, unknown function.

March 29**13** Fragmentary marble statue (Silenus) I.1.27

AC IV, 72, “Una statuetta rotta, senza la testa e senza la mano destra e il piede destro. Essa ha sulla coscia destra come un otre. E’ alta palmi tre, compresa la base di figure circolare”; *PAH* II 460, “una statuetta frammentata mancante della testa, della mano destra e del piede destro. La medesima tiene sulla coscia sinistra forse un otre: la sua intera altezza compresovi la testa e la base, ch’è di figura circolare, è di circa pal. 3”; Falkener 1852, 70, “the statue of a man with a bagpipe, and 2 ft. 8 in height, was found in front of tablinum”; Dwyer 1982, 24–25, i. *Dimensions*: H ca 80 (*AC*, *PAH*). *Present location*: In MANN *Reg. Im.* 22.7.1847, the piece is listed with the note that it remained in Pompeii, “Statuetta frammentata alla quale mancano la testa, mano e piede destra. Rimasta a Pompei”. Not located. *Functional category*: Object of art/plastic figure.

14 Marble plates

PAH II, 460, “altri piccoli pezzi di lastre frammentate”. *Discussion*: in connection with the marble statue Cat. 12 above. Not mentioned in *Annali comunali* or by Falkener. *Present location*: Probably left in Pompeii. *Functional category*: Architectural, revetment plates.

15 Bronze coin

PAH 460, “una moneta di modulo mezzano”; Falkener 1852, 45, n., “three coins”. *Present location*: MANN *Reg. Im.* 22.7.1847, “una moneta di mezzano modulo”. Not located. *Discussion*: According to the *PAH*, two other coins, yielding the total of three mentioned by Falkener, were found on April 6 in the upper layers of atrium, see below Cat. 37–38. *Functional category*: Instrument, economic.

16 Glass bottle

AC IV, 72, “un vase lacrimale”; *PAH* 460, “un lacrimatoio”; Falkener 1852, 45, n., “lachrymatory”; Dwyer 1982, 25, ii. *Present location*: MANN *Reg. Im.* 22.7.1847. Possibly *SG* 2785, “Lagrimatojo lungo circa once quattro”. Possibly *Inu. Fiorelli*, 12189. Not located. *Dimension*: H 8.8 (*SG*). *Comments*: A drop-shaped small *unguentarium*, which must belong to the general type Scatozza 47. *Functional category*: Vessel, medical/cosmetic.

17 Iron hammer

AC IV, 72 = *PAH* 460, “Ferro. Un martello”; Falkener 1852, 45, n., “iron hammer”; Minervini 1854, 20, “una martellina (*malleus*)”; Minervini 1855, 83 “una martelletta”. *Present location*: MANN *Reg. Im.* 22.7.1847, *SG* noted at the margin. *SG* 8296, “martello di ferro ossidato, lungo circa once nove e mezzo”. Not located. *Dimensions*: L 20.9. *Functional category*: Instrument, hardware tool (carpentry).

18 Fragments of gilded stucco mouldings

AC IV, 72, “vari pezzi di cornicetta dorata”; *PAH* II, 460, “vari pezzi di cornicette dorate”. *Present location*: MANN *Reg. Im.* 22.7.1847. Not located. *Comments*: Similar to Cat. 18, 26, 46, 220, 222, 223, see discussion for structural finds. *Functional category*: Architectural, ceiling decorations.

19 Ten cylindrical bone hinges

AC IV, 72 = *PAH* 460, “dieci pezzi cilindrici forati”; Falkener 1852, 45, n., “ten pieces of cylindrical bone, perforated”; Minervini 1854, 20, “molti di quei pezzi cilindrici forati, e con varii buchi alla esterna circonferenza, dei quali non fu possibile finora determinar l’uso, abbenchè sieno tanto frequentemente venuti fuori dalle pompeiani scavazioni.” = 1855, 84. *Present location*: *Reg. Im.* 22.7.1847, “dieci pezzi di osso cilindrici e forati”. Not located. *Comments*: The group of ten bone hinges points to the collocation of a wooden storage container, an *armarium*, in the atrium area. *Functional category*: Fixture, closure (container).

April 8**20** Terracotta lamp

AC IV, 73 = *PAH* II, 461, “una lucerna rotta”; Falkener 1852, 45, n., “broken lamp”. *Present location*: *Reg. Im.* 22.7.1847, “lucerna rotta”. Not located. *Functional category*: Instrument, lighting.

21 Terracotta handle

AC IV, 73 = *PAH* II, 461, “un manico di patera”; Falkener 1852, 45, n., “handle of a patera”. *Present location*: MANN *Reg. Im.* 22.7.1847, *SG* noted at the margin. *SG* 5252 (*Terrecotte*), “manico di patera con testa di pantera lungo circa once quattro”. Not located. *Dimensions*: L 8.8 (*SG*). *Comments*: The word *patera* would indicate a shallow vase with one horizontal handle. The animal protome at handle would indicate that this was a rare reproduction of Tassinari’s patera type H in terracotta. Cf. a handle fragment with ram’s head in glazed terracotta in Metropolitan Museum of Art. Inv. 17.194.1722. *Functional category*: Vessel, pouring (or cooking).

April 20**22–25** Four iron nails

PAH II, 462, “quattro chiodi di diverse lunghezze”, cf. Falkener 1852, 45, n., “several oxidized nails”. *Present location*: MANN *Reg. Im.* 22.7.1847. Not located. *Functional category*: Fixture, furniture.

26 Fragments of gilded stucco mouldings

PAH II, 462, “vari frammenti di cornicette dorate, simili a quelle rinvenute ne’ precedenti giorni”. *Present location*: *Reg. Im.* 22.7.1847. *Comments*: Similar to Cat. 18, 26, 46, 220, 222, 223, see discussion for structural finds. *Functional category*: Architectural, ceiling decorations.

27 Human skull

PAH II, 462, “la parte superiore di un cranio umano”; Falkener 1852, 45, n., “the upper part of a skull”. *Present location*: Probably left in Pompeii. *Comments*: The *PAH* lists the find on the day that saw the final clearing of the cubiculum R5, but Falkener explicitly locates it in the atrium. It might come, however, from the SE adjoining rooms of the atrium, and be part of the skeleton and lower jaw (Cat. 141) found on April 14, when work was done in the ala R8 and tablinum R15. *Functional category*: Organic.

April 22**28–32** Five bronze nails

PAH II, 462, “cinque piccoli chiodi con teste larghe”. *Present location*: MANN *Reg. Im.* 22.7.1847, “cinque piccoli chiodi con testa larga”. Not located. *Comments*: Not explicitly mentioned by Falkener, but most probably from the area in or around the atrium. *Functional category*: Fixture, furniture.

33–34 Two bronze strap hinges

PAH II, 462, “una scibba a meccione. Altra per metà, per lo stante”; Falkener 1852, 45, “three door-hinges”. *Present location*: MANN *Reg. Im.* 22.7.1847. Not located. *Comments*: Adding to one hinge found, according to the *PAH* on April 6, in the upper strata of the atrium. *Functional category*: Fixture, closure (door).

35 Fragmentary glass cup

PAH II, 462, “il fondo di una coppa”; Falkener 1852, 45, n., “part of a cup”. *Present location*: MANN *Reg. Im.* 22.7.1847. Not located. *Functional category*: Vessel, culinary consumption.

Atrium area, upper layers: I floor.

April 6, “dall’alto delle terre”.

36 Wing of a bronze strap hinge

AC IV, 73, “mezzo arpione da porta”; PAH II, 461, “una mezza scibba di porta”; perhaps included in Falkener 1852, 45, “three door-hinges”. *Present location*: Reg. Im. 22.7.1847. Not located. *Comments*: Falkener mentions three door-hinges and three folding door hinges from the atrium area. *Functional category*: Fixture, closure (door).

37–38 Two bronze coins

AC IV, 73 = PAH II, 461, “due monete di modulo mezzano”, Falkener 1852, 45, n., “three coins”, see above Cat. 15. *Present location*: MANN Reg. Im. 22.7.1847. Not located. *Comments*: Among the three mentioned by Falkener. *Functional category*: Instrument, economic.

39 Bronze nail

AC IV, 73 = PAH II, 461, “un chiodo”. *Present location*: MANN Reg. Im. 22.7.1847. Not located. *Comments*: Not explicitly mentioned by Falkener. *Functional category*: Fixture, furniture.

40 Bone fitting

AC IV, 73, “un pezzo lavorato ad uso di guarnizione”; PAH II, 461, “un pezzo lavorato per guarnizione”. *Present location*: MANN Reg. Im. 22.7.1847, SG noted at the margin. SG, *Bronzi minuti*, 8305, “un pezzo di osso per guarnizione avendo lavorato a graffito una palmetta, lunga once due e mezzo per oncia una e due quinti”. Not located. *Dimensions*: 5.5 x 3.9 (SG). *Comments*: Not mentioned by Falkener. Only the Naples inventory describes this piece of furniture decoration as having an engraved palmette on it, and reports its dimensions. *Functional category*: Fixture, furniture.

41 Bone spoon

AC IV, 73, “un altro ad uso di pulire le orecchie”; PAH II, 461, “un pezzo forse per pulire l’orecchio”; Falkener 1852, 45, n., “ear-pick”; Minervini 1854, 20, “uno stuzzicorecchi (*auriscalpium*)” = 1855, 84. *Present location*: MANN Reg. Im. 22.7.1847, SG noted at the margin. SG, *Bronzi minuti*, 8306, “un pezzo di osso forse per pulire le orecchie, lungo once cinque e due quinti”. Not located. *Dimensions*: 11.9 (SG). *Comments*: This must be a simple bone probe, ending in a small discoid or spoonlike bowl. Found in the upper layers, and perhaps coming from upstairs. *Functional category*: Instrument, medical/cosmetic.

42 Small terracotta vase

AC IV, 73, “un piccolo vase unguentario”; PAH II, 461, “un piccolo vasettino forse unguentario”; Falkener 1852, 45, n., “ointment vase”. *Present location*: MANN Reg. Im. 22.7.1847, “piccolo vasettino di terracotta forse un unguentario”. Not located. *Comments*: Identification of the object is uncertain. Terracotta *unguentaria* do not belong to the *instrumenta* of the Flavian age. *Functional category*: Vessel, medical/cosmetic.

43 A group of iron nails

AC IV, 73 = PAH II, 461, “varj chiodi ossidati”; Falkener 1852, 45, n., “several oxidized nails”. *Present location*: MANN Reg. Im. 22.7.1847. Not located. *Functional category*: Fixture, furniture.

April 7**44** Circular marble table

Falkener 1852, 70, “a circular table was found April 7, which had fallen from the same room”, Dwyer 1982, 25, i. *Present location*: Probably left in Pompeii. *Comments*: This item is not mentioned by the PAH or Minervini, and does not appear in the Reg. Im. of the MANN. *Functional category*: Furniture.

April 10, PAH “dall’alto delle terre”, Falkener 1852, 70, “from 1st floor”. Upper layers.

45 Marble support I.1.27

AC IV, 73, “Marmo. Un pezzo a foggia di tronco d’albero”; PAH II, 461, “un tronco di albero per sostegno di statuetta”; Falkener 1852, 70, “marble trunk of a tree, which had served as support to some statue, was found in the atrium”; Minervini 1854, 21, “un tronco d’albero che forse serviva di sostegno; se però dir non si voglia

sostegno di qualche statuetta” = 1855, 86. *Present location*: MANN *Reg. Im.* 22.7.1847. *SG, Marmi*, 5259. Not located. *Functional category*: Object of art/plastic figure.

46 Fragments of gilded stucco moulding

AC IV, 73 = *PAH* II, 461, “varj pezzi di cornici indorate”. *Present location*: MANN *Reg. Im.* 22.7.1847. Not located. *Comments*: Similar to Cat. 18, 26, 46, 220, 222, 223, see discussion for structural finds. *Functional category*: Architectural, ceiling decorations.

47 Fragments of floor mosaic

Falkener 1852, 70, “That the first floor was nobly paved, appears from fragments of mosaic pavements found at various heights in the course of excavation.” *Present location*: Probably left in Pompeii. Not located. *Comments*: Not mentioned in the *AC*, *PAH* or Registro Immissioni MANN. *Functional category*: Architectural, floor decorations.

R4 CUBICULUM (with R3 cella)

The excavation of the first decorated cubiculum to right, R4,⁵ was carried out on March 23 and 24; the work proceeded speedily, as part of a special show excavation into the three first small rooms (R3, R4, R6) at the front part of the atrium. The finds from the first two rooms are mixed up, without any record of more specific provenience, as reported in *PAH* II, 459: “si sono disterrate due stanze, una a destra e l'altra a sinistra del protiro, e si sono raccolti li seguenti oggetti antichi”. Falkener writes that over the course of these two days they “finished the excavation of this cubiculum and the closet under the stairs”, and he thus lists the finds from R3 (cella ostiaria) and the cubiculum R4 together, although he separated out those of the left cubiculum R6. For R6, some realistically described details, such as making casts of the wicker baskets that protected the glass bottles, make Falkener's report seem quite reliable. On the other hand, some errors regarding the finds of R4 suggest that in this case he in part merely copied the original inventory (for example, calling the bronze bowl, ‘conca’, a ‘bottle’, and the marble head, ‘testa Bacchica di rosso antico’, a ‘cup’. Three groups of finds mentioned only once in the *PAH* (*i.e.* scales, ten nail-heads, lantern) have, perplexingly, been duplicated by Falkener, resulting in a situation where they are reported to have been found both in R4 and R6.⁶ It should be noted that Falkener also omits important details, such as the presence of the two pedestals of the two small glass cups in R4. Panofka mentions only that in R4 ‘si trovò una quantità grande di talco’, confusing it, again, with R6.⁷ Finally, Breton eclectically listed some finds as enumerated by Falkener, including a ring, bottle (following the erroneous reading of Falkener), many hinges, the second scales, many cylinders, five rings, a money box, cups in red terracotta, one with barley, two knife handles, two axes, two knives, many vases in glass, and many pieces of blue colour.⁸

March 23

48 Gold ring III.4.1

AC IV, 72, “un anello con un riccio marino rilevato al di sopra e una piccola pietra verde” = *PAH* II, 459, “...

⁵ *PAH* II, 459; Panofka 1847 a, 137; Avellino 1848, 4; Pancaldi 1848, 10; Falkener 1852, 43, 50–51; Minervini 1854, 4–5; Minervini 1855, 53; Breton 1855, 299; Dwyer 1982, 25–28; *PPM* IX, II, 159–167; Tammisto – Kuivalainen 2008, 85–86.

⁶ It might be further hypothesised that, in the *PAH* list of bronzes, all the finds listed after the scales might in fact come from room 6. This is supported by the fact that the list first enumerates pieces in the traditional order of ‘value’ from bowl to minute bronze fragments, and then “restarts” from the scales, possibly as a sign of different provenience. Another support for this hypothesis is that, differently than for other rooms, Falkener does not cite the complete list of finds from Room 6 in a footnote, but includes them in the text. Possibly these are only the highlights of the inventory of the room.

⁷ Panofka 1847a, 137.

⁸ Breton 1870, 396–397.

ed una pietra verde”; Falkener 1852, 51, n., “a ring with the ornament of a cockle-shell”; Minervini 1854, 19 “un anellino di oro coll’ornamento di una conchiglia e di una pietra turchina” = 1855, 81. *Present location*: MANN *Reg. Im.* 22.7.1847, “...rilevato di una pietruzza verde”, *SG* signed at the margin. *SG*, *Oggetti preziosil Commestibili*, 455. *Inv. Fiorelli*, 25044. *Functional category*: Personal adornment.

49 Bronze bowl

AC IV, 72, “una conca di forma circolare di 9/19 di palmo”; *PAH II*, 459, “una piccola conca di forma circolare del diametro di circa 9/10 di pal.”; Falkener 1852, 51, “a small bottle, nine inches diameter”; Dwyer 1982, 27, vi. *Present location*: MANN *Reg. Im.* 22.7.1847. Not located. *Dimensions*: D. ca. 23.5. *Comments*: The object is described in the *PAH* as a ‘conca’, an open dish of rounded shape. Falkener, although confirming the diameter, erroneously translates this as a bottle, surely not based on visual observation of the vase. The small diameter excludes the possibility that the vessel could belong to the basins of Category S of Tassinari, which have considerably larger diameters, and points rather to category M. This group includes shallow dishes of exactly this diameter, in particular in group M1000 ‘coppe’ (for example inv. Pompeii 1420 and 11941, Tassinari 1993, II, 166–167). *Functional category*: Vessel, containing liquid (bowl or basin).

50 Bronze colander

AC IV, 72, “un colatoio col manico”; *PAH II*, 459, “un passabrodo col suo manico, esso privo del fondo”; Falkener 1852, 51, “bronze cullender with handle”; Dwyer 1982, 27, v. Minervini 1854, 20, mentions only generally *coli* among the shapes of vases found in the house. *Present location*: MANN *Reg. Im.* 22.7.1847, “un passabrodo”. Not located. *Comments*: ‘Passabrodo’ or *colum* undoubtedly refer to the ‘colini’ with a long horizontal handle, of Category K 3000 of Tassinari (1993, II 160–161), decorated at the bottom with ornamental perforations. *Functional category*: Vessel, pouring and sieving (wine).

51–54 Four bronze lock plates

AC IV, 72, “quattro pezzi di serratura”; *PAH II*, 459, “quattro scudi di serrature rotti in più parti”; Falkener 1852, 51, “four bronze escutheons of locks”; Minervini 1854, 19, mentions that diverse pieces of locks (lucchetti, arpioni, chiavi) were found in the house, without further description of their form or provenience. *Present location*: MANN *Reg. Im.* 22.7.1847. Not located. *Comments*: Lock plates; it is not possible to ascertain their measure of form. *Functional category*: Closure.

55–59 Five bronze strap hinges

AC IV, 72, “cinque arpioni da porta”; *PAH II*, 459, “cinque scibbe per lo stante della porta”; Falkener 1852, 51, “five door hinges”. *Present location*: MANN *Reg. Im.* 22.7.1847, “cinque scibbe per porta”. Not located. *Comments*: As these hinges are characterized as door hinges, they would most probably be large strap hinges consisting of two movable arms, used for structural doors. *Functional category*: Fixture, closure (structural door).

60–63 Four bronze locks

AC IV, 72 = *PAH II*, 459, “quattro lucchetti”; Falkener 1852, 51, “four hasps of locks”. *Present location*: MANN *Reg. Im.* 22.7.1847, *SG* signed at the margin. *SG*, *Bronzi minuti*, 8286–8289. Not located. *Comments*: The definition of ‘lucchetti’, small locks, remains vague. The expression of Falkener, hasps of locks, would rather refer to a kind of clasp. In both cases the diminutive makes it reasonable to suppose that the elements were derived rather from smaller containers rather than doors. *Functional category*: Fixture, closure (container).

64–67 Four bronze pivot hinges

AC IV, 72, “quattro arpioni anche da porta con le piastre corrispondenti”; *PAH II*, 459–460, “quattro billici di porta colle corrispondenti piastre”; Falkener 1852, 51, “four cylinder hinges with corresponding plates”. *Present location*: MANN *Reg. Im.* 22.7.1847. Not located. *Comments*: The objects must derive from at least two, if not four doors. Therefore, they must have been stored disassembled in this cubiculum, out of their context of use, perhaps intended to be used in the construction works of the upper part of the house. *Functional category*: Fixture, closure (structural door).

68 Bronze vase handle

AC IV, 72, “un picciolo manico di vase”; *PAH II*, 460, “un piccolo manico di vaso”, Falkener 1852, 51, “a small

vase handle". *Present location*: MANN *Reg. Im.* 22.7.1847. Not located. *Functional category*: Vessel, unknown function.

69 Bronze furniture ornament

AC IV, 72, "un piccolissimo ornamento di mobile"; *PAH II*, 460, "un piccolissimo ornamento di mobile"; Falkener 1852, 51, "ornament of furniture". *Present location*: MANN *Reg. Im.* 22.7.1847. Not located. *Comments*: The diminutive object presumably had very modest, non-figurative ornamentation, as it was not described in detail, and without giving its dimensions in any of the accounts. *Functional category*: Fixture, furniture fitting.

70 Five bronze rings

AC IV, 72 = *PAH II*, 460, "cinque diversi anelli"; Falkener 1852, 51, "five rings". *Present location*: MANN *Reg. Im.* 22.7.1847. Not located. *Comments*: Bronze rings are very common finds, as they were elements of numerous kinds of objects, from lanterns to box or furniture handles. The *AC* and *PAH* specify that the rings were different from each other, and thus probably elements of diverse objects. *Functional category*: Fixture, unknown function.

71 Bronze coin

AC IV, 72 = *PAH II*, 460, "una moneta di modulo mezzano", Falkener 1852, 51, "a coin". *Present location*: MANN *Reg. Im.* 22.7.1847. Not located. *Functional category*: Instrument, economic.

72 Terracotta money-box III.4.4

AC IV, 72, "una salva-monete di figura parallelepipedo"; *PAH II*, 460 "un salvamoneta in forma di parallelepipedo"; Falkener 1852, 51, "square money-box"; Minervini 1854, 21, pl. IV, 13 "a forma di cassetino, con un'apertura nel mezzo, per potervi introdurre le monete" = 1855, 85. *Present location*: MANN *Reg. Im.* 22.7.1847, SG signed at the margin. *SG, Terrecotte*, 5244. *Inv. Fiorelli*, 16813. *Functional category*: Instrument, economic.

73–74 Two terracotta mugs

AC IV, 72, "due pignattini diversi"; *PAH II*, 460, "due pignattini diversi uno di essi col manico rotto"; Falkener 1852, 51, "two small pots". *Present location*: MANN *Reg. Im.* 22.7.1847, "due pignattini uno dei quali rotto". Not located. *Comments*: Of the two pots, at least one had a handle, and the form could therefore be a small plain jug or rather a mug in thin-walled ware. *Functional category*: Vessel, culinary consumption.

75 Terra sigillata cup

AC IV, 72 = *PAH II*, 460, "una piccola tazzolina circolare con vernice rossa"; Falkener 1852, 51, "small tazza covered with red varnish". *Present location*: MANN *Reg. Im.* 22.7.1847. Possibly *SG, Terrecotte*, 5245 "tazza circolare con vernice rossa in buono stato di conservazione". Not located. *Comments*: The description only allows the identification of the fabric as *terra sigillata* and the form as a small cup; the definition 'circolare' could refer to hemispherical, rounded form. *Functional category*: Vessel, culinary consumption.

76–77 Two terra sigillata bowls, one containing barley

AC IV, 72, "due tazzoline più grandi rotte nel labbro, una delle quali contiene orzo carbonizzato"; *PAH II*, 460, "due più grandi rotte nel labbro, una di esse contenente dell'orzo carbonizzato"; Falkener 1852, 51, "two larger ditto, one of which contains barley calcinized"; Minervini 1854, 21, "...l'essersi ritrovata in uno dei cubicoli una patera di rossa vernice, contenente orzo calcinato" = 1855, 86; Wittmack 1903; Dwyer 1982, 28, xxii–xxiii; Borgoncino 2006, 124, cat. 372. *Present location*: MANN *Reg. Im.* 22.7.1847. *SG, Terrecotte*, 5286–5292. *Inv. Fiorelli*, 22876–22882(?). *SG, Commestibili*, 194, "tazza rotta nel labbro contenente orzo carbonizzato, vi sono piccole pietre fra l'orzo (9495 cons. provv. Pompei)." *Inv. Fiorelli*, 84617, "della biada carbonizzata. *Inv. Cit.* 194. Pompei. Riposta in un piatto moderno". Not located. *Comments*: M. Borgoncino, who has catalogued the organic finds of the MANN (2006), has not found the item. The last autoptic description is from Wittmack, 1903, "Hordeum hexastichum oder tetrastichum, klein Gerste, 10,5 lang, 4 mm breit, 3,25 mm dick, heller braun und schmaler als nr. 84614". Borgoncino (2006, 47–48) notes that in the imperial period barley was mostly used for animal fodder. According to the description, the two *terra sigillata*

vases should have been either large cups or small bowls. *Functional category*: Vessel for culinary consumption.

78 Bone knife handle

AC IV, 72 = PAH II, 460, “un manico di coltello”, Falkener 1852, 51, “knife handle”, Dwyer 1982, 27, ix. *Present location*: MANN Reg. Im. 22.7.1847. Not located. *Comments*: Knife with an iron blade inserted into a bone handle; a relatively small knife. *Functional category*: Instrument, possibly medical/cosmetic.

79 Horn

AC IV, 72 = PAH II, 460, “un corno rotto nell’estremità”; Falkener 1852, 51, “horn”; Minervini 1854, 20, “un piccolo corno bovino, del quale non ci attentiamo a determinare l’uso” = 1855, 84. *Present location*: MANN Reg. Im. 22.7.1847. SG, *Bronzi minuti*, 8290, “un corno rotto nell’estremità, lungo circa mezzo palmo”. Not located. *Dimensions*: ca 13.2 (SG). *Comments*: Animal horns appear frequently among Pompeian finds, and might have been kept as amulets, or also as raw material to produce burnt medical, magic, or cosmetic ingredients. *Functional category*: Organic.

80 Iron axe 81

AC IV, 72 = PAH II, 460, “un’acchetta”; Falkener 1852, 51, “hatchet”; Minervini 1854, 20 “[due] accette (*se-cures*)” = 1855, 83. *Present location*: MANN Reg. Im. 22.7.1847. Not located. *Comments*: The object can be identified as a small iron axe, of unspecified form. *Functional category*: Instrument, hardware tool (carpentry).

81–82 Two iron knives

AC IV, 72 = PAH II, 460, “due coltelli”, Falkener 1852, 51, “two knives”, Dwyer 1982, 27, vii–viii. *Present location*: MANN Reg. Im. 22.7.1847. Not located. *Comments*: The objects were possibly blades of larger knives or scalpels, perhaps connected with the other hardware tools found in the room. *Functional category*: Instrument, cutting (kitchen?).

83–84 Two iron pruning knives

AC IV, 72, “due ronche”; PAH II, 460, “due roncigli”; Falkener 1852, 51, “woodman’s bill”; Minervini 1854, 20, “due ronche (*runcones*)” = 1855, 83–84. *Present location*: MANN Reg. Im. 22.7.1847, “due roncini”. Not located. *Comments*: Bill-hooks or pruning knives for agricultural use, cutting arbusts or vine. *Functional category*: Instrument, hardware tool (agriculture).

85–88 Four glass bottles

AC IV, 72, “quattro caraffinette diverse”; PAH II, 460, “quattro caraffinette diverse, due delle quali rotte nel collo”; Falkener 1852, 51, “four small jars”; Dwyer 1982, 28, xiv–xviii. *Present location*: MANN Reg. Im. 22.7.1847, “...delle quali tre son rotte”. Not located. *Comments*: The word ‘caraffa’ or ‘caraffinetta’ can refer in the *Giornali* to various shapes of *unguentaria*, such as the pear-shaped bottles Scatozza 1986, form 46 or form 49. The broken necks of the vases suggest that the forms originally had relatively long and slender necks. *Functional category*: Vessel, medical/cosmetic.

89 Small glass bottle

Missing in AC; PAH II, 460, “un altra piccolissima rotta pure nel collo”, missing in Falkener 1852; Dwyer 1982, 28, xviii. *Present location*: Not mentioned in MANN Reg. Im. Not located. *Comments*: There is considerable confusion about this small vase. It is mentioned only in the PAH; the *Annali civili* omit it, and Falkener and even the *Registro delle Immissioni* omit it. If it exists, this should, however, be a small glass *unguentarium*. *Functional category*: Vessel, medical/cosmetic.

90–91 Two glass cups with accompanying pedestals II.3.1, II.3.2, II.3.3, II.3.4

AC IV, 72, “due piccole tazze circolari con le basi corrispondenti”; PAH II, 460, “due piccole tazze circolari colle corrispondenti basi, una di esse priva di un piede, e l’altra in frammenti”; Falkener 1852, 51, n., “two very small vases”; Minervini 1854, 21, “un bicchiere col suo piede *incitega*”, tav IV, 3 = 1855, 84. *Present location*: MANN Reg. Im. 22.7.1847, SG signed at the margin. SG, *Vetri*, 2793–2796, “Due piccole tazze circolari colle corrispondenti basi, restaurate. Altezza delle tazze da due a tre once.” *Inv. Fiorelli* 11666, pedestal inv. 11667; inv. cup 11668, inv. pedestal 11669. *Functional category*: Vessel, culinary consumption (tableware).

92 Glass spoon II.2.5

AC IV, 72, “un cucchiaino senza manico”; *PAH* II, 460, “un cucchiaino privo del suo manico”, Falkener 1852, 51, “bowl of a spoon”, Minervini 1854, 21, “la parte concava di un cucchiaino (*ligula*)” = 1855, 54. *Present location*: MANN *Reg. Im.* 22.7.1847, *SG* signed at the margin. *SG*, *Vetri antichi*, 2797, “cucchiaino privo del suo manico, lungo circa due once”. *Inv. Fiorelli*, 12086. *Functional category*: Vessel, culinary consumption (or cosmetic instrument).

93 Glass cup

AC IV, 72, “alcuni frammenti di bicchieri”; *PAH* II, 460, “alcuni frammenti di un bicchiere”; Falkener 1852, 51, “drinking cup”; Dwyer 1982, 28, xix. *Present location*: MANN *Reg. Im.* 22.7.1847. Probably *SG*, *Vetri antichi*, 2799, “alcuni frammenti di un bicchiere”. Not located. *Comments*: The earlier *Annali civili* list refers to several drinking glasses, in plural, whereas the other sources mention only one fragmented glass. *Functional category*: Vessel, culinary consumption.

94 Bust of Bacchus in rosso antico I.1.19

PAH II, 460, “una testa Bacchica di rosso antico, di altezza 3/5 di pal.”; Falkener 1852, 51, “cup of rosso antico”; Minervini 1854, 21, “una bacchica testa di rosso antico” = 1855, 86. This piece is not mentioned in *AC*. *Present location*: MANN *Reg. Im.* 22.7.1847. *SG*, *Marmi*, 1626. *Inv. Fiorelli*, 6441. *Functional category*: Object of art/plastic figure.

95 Three pieces of blue pigment

AC IV, 72, “tre piccoli pezzi di color *belletto*”; *PAH* II, 460, “Colore: tre piccoli pezzi di *belletto*”; Falkener, 51, “three small pieces of blue colour for painting”. *Present location*: MANN *Reg. Im.* 22.7.1847. Probably *SG*, *Oggetti preziosi/Commestibili*, 148 (Consegna provvisoria, 9496) “Quattro piccoli pezzi di *belletto* riposti in carta”. Not located. *Functional category*: Cosmetic/painting.

R5 CUBICULUM

In the *PAH*, the findings of April 15 are described as deriving from “the second cubiculum at the right side of the atrium”,⁹ at the height of 105,6 cm ca, “all’altezza di 4 pal. incirca”. The list of finds of that day corresponds to Falkener’s find list for that room, adding only some further minor items: two bronze pivots (Cat. 97–98), and a small bronze piece that seems to be a lock with iron attached (Cat. 120). Minervini notes that the most important find from the room was a set of medical instruments and a candelabrum, ‘non pochi istrumenti chirurgici e un grazioso candelabro’.¹⁰ Further work in the room was evidently carried out on April 20, when the silver sheath (Cat. 123) belonging to the medical ensemble was found. The other finds from this day included pieces of gilded ceiling stucco and the upper part of a cranium, which Falkener places in the atrium. The four iron nails (Cat. 22–25) mentioned for this day, and listed here among the atrium finds, might come from R5, or from the adjoining rooms of the SE corner of the atrium. Breton mentions only the candelabrum (Cat. 96) among finds from this room, curiously omitting the medical assembly.¹¹

April 15**96** Bronze candelabrum

AC IV, 73 = *PAH* II, 462, “un candelabro di altezza pal. 4, con tre basette e coppa dissaldata”; Falkener, 53, “candelabrum, 3 feet 4 inches high, remarkable for being terminated with an Ionic capital, and for having a

⁹ *PAH* II, 462; Panofka 1847 a, 136; Avellino 1848, 5–6; Pancaldi 1848, 10; Falkener 1852, 51–52; Minervini 1854, 5–6; 1855, 53; Breton 1855, 299; Dwyer 1982, 29; *PPM* IX, 167–186, Tammisto – Kuivalainen 2008, 85–86.

¹⁰ Minervini 1854, 6=1855, n. 85, 54.

¹¹ Breton 1870, 397.

hook instead of a patera, whereon to place the lamp”; Minervini 1854, 20, “E’ notevole un candelabro con l’asta di ferro, il piede e la testa in bronzo. La base poggia sopra quattro zampe di leone, la testa è conformata a capitello jonico, ed ha un uncino per sospenderci la lucerna, invece di coppa. Il fusto di ferro è in massima parte perduto per l’ossidazione” = 1855, 82; Dwyer 1982, 29, i. *Present location*: MANN *Reg. Im.* 22.7.1847, “candelabro alto pal. 4 con tre basette e coppa dissaldata”, *SG* noted at margin. *SG, Bronzi minuti*, 8462, “Candelabro di bronzo di palmi quattro con tre basette a coppa dissaldata”. *Inv. Fiorelli*, 78548, “altro con lo stelo liscio sormontato da un semplice disco senza calice: lo stelo ha lunghi ovoli verso la sommità. Il piede è formato dai soliti tre piedi a zampe leonine ricoverti da tre laminette a fogliame. Altezza metro 1,030 tra un piede a altro mill. 210. Diametro del disco mill 90.” Not located. *Dimensions*: H 103.0; D disc 9.0 (*Inv. Fiorelli*). *Comments*: All sources agree that the candelabrum is well preserved and in some way remarkable for its shape: however, its exact form is described in radically different ways. Most sources agree that it has three leonine feet, and probably also – as the Fiorelli inventory states – a leaf ornament on top of these. Minervini, surprisingly, states that the stem was made of iron. Most problematic are the differences in describing the top. It is possible that two items are confused. In fact, the candelabrum *SG* 8359 is described as having hooks for suspending the lamps: “piccolo candelabro di ferro di altezza un palmo e once sette. Ha perduto due dei tre sostegni a guisa di zampe che ne formano il piede. Ha sopra una piastrina di circa tre once e tre quinti di diametro, sotto della quale sono due ferri a guisa di uncini, forse per sospendere le lucerne.” The ionic capital is not described in any of the MANN inventories, and it is probable that Falkener and Minervini confuse it with the one found in IX 3, 2, also described (p. 88, n.) as “an iron candelabrum, with bronze feet, capital and cup”. *Functional category*: Instrument, lighting.

97–98 Two bronze pivot hinges

AC IV, 73, “due arpioni di porta”; *PAH* II, 462, “due billici di porta, uno privo di piastra”; Falkener 53 n., “two cylindrical hinges”. *Present location*: MANN *Reg. Im.* 22.7.1847. Not located. *Discussion*: These cylinder-and-socket hinges could be parts of the structural door of cubiculum R5. *Functional category*: Fixture, closure (structural door).

99–100 Two bronze tweezers

AC IV, 73, “due pinzette, ad una delle quali è attaccato un tasto cerusico”; *PAH* II, 462, “due pinsette ad una di esse si è attaccato un tasto cirusico”; Falkener, 52, “two small forceps”; Minervini 1854, 20, “due pinzette, *vulsellae* dei Latini. Esse, come in altre pubblicate dal cav. Vulpes (Memor della reg. Accad. Ercolanese vol VII pag. 133 seg. Tav. V) hanno gli estremi alquanto ricurvi, ed i margini forniti di piccoli denti acuti, che s’incastano insieme, quando le due estremità si avvicinano” = 1855, 83. *Present location*: MANN *Reg. Im.* 22.7.1847, “due pinzette, ad una di esse è attaccato un tasto cerusico”, *SG* noted at margin. *SG, Bronzi minuti*, 8308–8309, “due pinsette di bronzo. L’una è lunga once sei e quattro quinti, l’altra cui è attaccato un ferro informe ad un manubrietto di bronzo, è lunga once sette”. Not located. *Dimensions*: L 12 and 14 (*SG*). *Discussion*: The tweezers are described in most detail by Minervini 1854, who also gives them illustrated parallels in Vulpes. Vulpes tav. V. fig. I is a tweezer with broad arms, inturned, with dented points. *Functional category*: Instrument, medical/cosmetic.

101–106 Six bronze scalpels III.2.1, III.2.2

AC IV, 73 = *PAH* II, 462, “tasto da cirusico” [attached to two tweezers, above], “cinque tasti da cirusico”; Falkener, 52, “six probes”; Minervini 1854, 20, “alcuni scalpelli (*scalpella*) di forma somigliante a quelli pubblicati dallo stesso cav. Vulpes (v. tom. Cit. tav. VII). Solo è da notare che la lama è quasi interamente distrutta; per modo che non può diffinirsi in qual modo fosse propriamente conformata” = 1855, 83; Dwyer 1982, 29, iii–xvi. *Present location*: *Reg. Im.* 22.7.1847, *SG* noted at margin. *SG, Bronzi minuti*, 8310–8314, “Cinque tasti cerusici. Gli oggetti così denominati sono composti tre di essi di piccolo manubrio di bronzo e di lama di ferro. Il primo di questi è lungo once sette circa e gli altri due di once sei ed un quinto, e di questi uno ha un pezzo di legno e ferro aderente. Di due vi è il solo manubrio e sono lunghi circa once quattro e quattro quinti”. *Inv. Fiorelli* 77675–77679. Two located. *Functional category*: Instrument, medical.

107–108 Two bronze hooks II.2.3

AC IV, 73 = PAH II, 462, “due altri pezzi con piccoli rampini nell’estremità”; Falkener, 52, “two other instruments, with a slight projection at end”; Minervini 1854, 20, “due ametti (*hamuli*) simili a quelli editi da Vulpes cit. p. 138 tav. V fig. IX, X, XI” = 1855, 83. *Present location*: MANN Reg. Im. 22.7.1847, SG noted at margin. SG, *Bronzi minuti*, 8315–8316, “due altri pezzi con piccoli rampini nell’estremità, lunghi once sei e quattro quinti”. Inv. Fiorelli 78052 (one not located). *Functional category*: Instrument, medical.

109–114 Six bronze containers III.2.4, III.2.5

AC IV, 73 = PAH II, 462, “sei astucci di diversa grandezza, uno di essi con piccoli ferri al di dentro”; Falkener, 52, “six boxes, one of which contained several iron instruments”; Minervini 1854, 20, “Vi sono pure sei astucci o teche di bronzo, destinati a contenere varii instrumenti. Quattro sono più piccole, e due di più grandi dimensioni, una delle quali essendo aperta mostra le estremità di alcuni specilli (*specilla*)” = 1855, 83. Cf. Vulpes vol. vii, pag. 109 tav. iii, fig. viii. Bliquez 1994, 195, Cat. 308, fig. 203. *Present location*: MANN Reg. Im. 22.7.1847, SG noted at margin. SG, *Bronzi minuti*, 8317–8322, “sei astucci di bronzo di diversa grandezza. Quattro sono chiusi dall’ossido, lunghi uno once otto e due quinti, e gli altri da once quattro a quattro e mezzo, il quinto lungo once quattro e mezzo, contiene come pare un cerotto, il sesto privo di coperchio lungo once otto e mezza, ha internamente cinque specilli di forma diversa di lunghezza tra le once sette e mezzo alle once otto ed una molletta di circa once quattro e mezza di lunghezza”. Inv. Fiorelli, 78188–78193, “Altri sei di cui uno è grande, e gli altri sono di piccole dimensioni: ad eccezione del sesto gli altri sono muniti di coverchio, ed il quinto contiene un cerotto balsamico. Lunghezza del primo mill. 183 x 28, del secondo mill. 90 x 16, del terzo e quarto mill. 97 x 15, del quinto mill. 75 x 16 e del sesto mill. 87 x 17.” Two located: inv. Fiorelli 78188–78189. *Comments*: One of the six was located by Bliquez (inv. 78189), and another one in the present research (inv. 78188). *Functional category*: Instrument, medical.

115 Bronze cylinder (cannula) III.2.6

AC IV, 73, “un picciolo fallo forse per fontana”; PAH II, 462, “un piccolo fallo forse per scolo di acqua”; Falkener, 53 n., “fallos”; Minervini 1854, 20, “un piccolo fallo che l’antichità riteneva come un amuleto” = 1855, 82. *Present location*: MANN Reg. Im. 22.7.1847. SG, *Bronzi minuti*, 8323, “un piccolo fallo forse per scolo di acqua. Lunga once tre e un quinto”. Inv. Fiorelli, 69796. *Comments*: The form of the object led the excavators to compare it to a phallus, and Minervini 1854 surely has not seen the object, as his identification as an amulet is certainly erroneous. *Functional category*: Instrument, medical.

116–117 Two bronze lock plates

AC IV, 73, “due scudi di serratura di varia grandezza”; PAH II, 462, “due scudi di mascatura di diversa grandezza”, Falkener, 53 n., “two escutheons of locks”. *Present location*: MANN Reg. Im. 22.7.1847, “due scudi di mascatura di grandezza diversa, ad uno di essi vi è pure un chiodo di ferro”. Not located. *Functional category*: Fixture, closure.

118 Iron nail

PAH II, 462, “un chiodo di ferro”. *Present location*: MANN Reg. Im. 22.7.1847. Not located. *Comments*: Attached to Cat. 120. *Functional category*: Fixture, furniture.

119 Bronze ink-stand

AC IV, 73 = PAH II, 462, “un calamaio”; Falkener, 53, “inkstand”; Minervini 1854, 20, “un calamaio (*atramentarium*)” = 1855, 82. *Present location*: MANN Reg. Im. 22.7.1847, “un calamajo”. Not located. *Functional category*: Instrument, writing.

120 Bronze lock

AC IV, 73, “un altro pezzo come lucchetto con ferro ossidato”; PAH II, 462, “altro pezzo che sembra un lucchetto con ferro ossidato”. *Present location*: MANN Reg. Im. 22.7.1847, “altro pezzo che sembra un lucchetto di ferro ossidato”. Not located. *Comments*: Not mentioned by Falkener. *Functional category*: Fixture, closure.

121 Small bronze lock plate

AC IV, 73, “un picciolissimo scudetto di serratura appartenente a qualche cassetino”; PAH II, 462, “un pic-

colossimo scudetto di mascatura appartenente a qualche cassetto”, Falkener 53, n., “hasp”. *Present location*: MANN *Reg. Im.* 22.7.1847, “piccolo scudetto di serratura”. Not located. *Functional category*: Fixture, closure (container).

122 Porphyry slab

AC IV, 73 = *PAH* II, 462, “un piccolo pezzo quadrato di porfido”; Dwyer 1982, 29, xix. *Present location*: MANN *Reg. Im.* 22.7.1847. Not located. *Comments*: The material, form, and also context make it plausible that the object found was a *coticula*. Not mentioned by Falkener. Because of its rare material, green or red “porphyre”, this is probably the flat, rectangular object in green stone illustrated by Ceci 1858, tav. VII, 31. *Functional category*: Instrument, medical.

April 20

123 Silver instrument case

AC IV, 73 = *PAH* II, 462, “forse un fodero sconservato, di lunghezza cinque decimi di palmo”; Falkener, 52, “a silver case or instrument sheath, 5 inches long”; not mentioned by Minervini 1854; Dwyer 1982, 29, xviii. *Present location*: MANN *Reg. Im.* 22.7.1847. Not located. *Dimensions*: L ca 13.2 (*PAH*). *Comments*: The bad preservation and eventual disintegration of the object point to its being made of silver foil on organic material, i.e. wood or leather, rather than being solid silver. However, it may also have been of thin silver leaf. *Functional category*: Instrument, medical.

R6 CUBICULUM

The excavation of cubiculum R6¹² went on as a joint operation with the unearthing of R3 and R4 on 23–24 March 1847 (see R4). Falkener (p. 49) enumerates ten items as found in this room (Cat. 124–133). All items mentioned by Falkener are present in the *PAH* (p. 460) list among the finds made on those days, mostly among those made on 24 March. Panofka specifically mentions the finds from R6, some months after the excavation, highlighting only the glass items and the lantern: “ivi furono trovati molti frammenti di vetro ed una lanternina”.¹³ Breton, in his later guidebook, copies Falkener’s list for this room, mentioning all of the objects listed below.¹⁴

23 March

124 Bronze scales

AC IV, 72, “una bilancia in frammenti col romano e coppa”; *PAH* II, 460, “una bilancia in molti frammenti col suo romano e coppa”; Falkener, 49, “a small steelyard, the weight attached to which represented the head of Mercury”; 51, n., “a small steelyard with weight and cup”; Minervini 1854, 20, “[bilancia] In uno apparisce pure il peso a foggia di un busto virile” = 1855, 82; Dwyer 1982, 26, iv; 30, ii. *Present location*: MANN *Reg. Im.* 22.7.1847, “bilancia in frammenti col romano e coppa”, *SG* signed at the margin. *SG*, *Bronzi minuti*, 8486. Not located. *Comments*: Falkener includes scales in both R4 and R6. The one with a head of Mercury is not mentioned in the *AC* or the *PAH*, and it has not been included in the present catalogue. The find is comprised of three elements: the beam of the steelyard, a counterweight, and a small plate to hold the material to be weighed. *Functional category*: Instrument, weighing.

¹² *PAH* II, 460; Panofka 1847 a, 131; Pancaldi 1848, 9; Raoul–Rochette 1852, 79; Breton 1855, 300; Falkener 1852, 47–49; Minervini 1854, 6–7; Dwyer 1982, 30; *PPM* IX, 187–206; Tammisto – Kuivalainen 2008, 85–86.

¹³ Panofka 1847a, 131.

¹⁴ Breton 1870, 396.

125 Ten bronze studs

AC IV, 72, “dieci teste di chiodi”; PAH II, 460, “dieci teste di chiodo”; Falkener, 49, “ten nail-head ornaments of door”; 51, n., “ten nail-heads”, Dwyer 1982, 30, i. *Present location*: Reg. Im. 22.7.1847. Not located. *Comments*: These were most probably stud-like decorative nails with large flat heads and thin stems, judging from the partial preservation. It is quite probable that this group is the same as the ten items that Falkener (p. 49) reports from R6: “ten nail-head ornaments of a door”. *Functional category*: Fixture, furniture.

126 Glass cup

AC IV, 72, “i resti di una tazza blu”; PAH II, 460, “i frammenti di altra tazza di color blu”; Falkener, 49, “blue cup”; Minervini 1854, 21, “altra [tazza] di color bleu” = 1855, 84; Dwyer 1982, 31, vi. *Present location*: Reg. Im. 22.7.1847, SG 2081 signed at the margin. SG, *Vetri antichi*, 2800, “frammenti di una tazza di vetro color bleu”. *Inv. Fiorelli*, 12246, “Tazza di pasta vitrea bleu scanalata: è tutta frammentata, Alt. mill. 70. Diam. mill. 95 Restaurata”. Not located among the ribbed blue glass cups of the MANN collection. *Dimensions*: H 7.0; D 9.5 (*Inv. Fiorelli*). *Functional category*: Vessel, culinary consumption.

127–128 Two glass askoi II.2.6, II.2.7

AC IV, 72 = PAH II, 460, “due vasi a forma d’oca, uno col manico distaccato, e l’altro rotto nella parte inferiore”; Falkener, 51, “two glass vessels, of the beautiful oca form”; Minervini 1854, 21, “due specie di oenochoe, o prochoi, che veggonsi (tav. 1 fig. 15)” = 1855, 84. *Present location*: MANN Reg. Im. 22.7.1847, SG signed at the margin. SG, *Vetri antichi*, 2791–2792, “Due vasi a forma di otre con manico, lunghi circa once sette”. *Inv. Fiorelli*, 12008 and 12010. *Functional category*: Vessel, culinary consumption.

129 Glass cup II.2.8

AC IV, 72, “una tazza circolare, con fogliame all’intorno”; PAH II, 460, “una tazza circolare frammentata con fogliame in giro”; Falkener, 49, “glass plate, with a leaf scroll round the rim”; Minervini 1854, 21, pl. IV, 4, “un’altra graziosa tazza con ornamenti da noi riportata” = 1855, 84. *Present location*: MANN Reg. Im. 22.7.1847, SG 2799 signed at the margin. SG, *Vetri antichi*, 2798, “tazza circolare con fogliame in giro, restaurata”. *Inv. Fiorelli*, 11984, “Tazza con lavori a foglie nella pancia. Ha una piccola base e manca di un manico. E’ rotta ed è restaurata. Alt. mill 68, diametro nella bocca 135 mil.” *Comments*: It has been possible to identify the fragments of this cup, of rare fabric and decoration, in the MANN glass collection, on the basis of inventorial descriptions and, in particular, the drawing of Niccolini. *Functional category*: Vessel, culinary consumption (drinking wine).

130 Talc plates

AC IV, 72, “Talco. Molta quantità di tal minerale”; PAH II, 460, “una gran quantità di talco”, see previous entry. *Present location*: MANN Reg. Im. 22.7.1847, SG 2802 signed at the margin. SG, *Vetri antichi*, 2801, “molti pezzi di talco del peso di circa rotoli undici”; Panofka 1847 a, 137, “grande quantità di talco”. *Comments*: A large quantity of this material was found in the House of Marcus Lucretius. Falkener connects this find with the lantern, but the quantity of material seems excessive for that use, as the *Inventario SG* gives the combined weight as 9,790 kg. For the talc, a vitreous gypsum-like substance, see Beretta – Di Pasquale 2004, 281, cat. 3.4. *Lapis specularis* was transparent, easily shaped, and less costly than glass. It was extracted in Cappadocia from the time of Nero onwards, but according to Pliny (*nat.* 36.46.1) also from Sicilian and African caves, see De Carolis 2007, 37–39; Dell’Acqua 2004, 109–119. *Functional category*: Architectural (window glass?).

24 March**131** Bronze lantern III.1.1

AC IV, 72, “una lanterna rotta in più parti, munita delle catene corrispondenti, e del lumino con istoppino e fumajuolo”; PAH II, 460, “una lanterna rotta in varie parti, munita delle corrispondenti catene non che della lumiera, con stoppino e fumajuolo”; Falkener, 49 “lantern, with talc lights”; 51, n., “a lantern”; Panofka, 1847 b, “lanternina”, Minervini 1854, 20, pl. IV, 10–11, “graziosa lanterna perfettamente conservata” = 1855, 82. *Present location*: MANN Reg. Im. 22.7.1847, SG signed at the margin. SG, *Bronzi minuti*, 8291–8295,

“una lanterna rotta in varie parti e munita delle corrispondenti catene, nonche della lumiera con stoppino a fumajuolo. La lanterna e lunga comprese le catene un palmo e once sette. Ha tre pezzi distaccati, l'uno e un coverchio circolare e forato dentro un lumicino di diametro di once due, l'altro e lo spegnitojo, lungo once cinque il terzo e un piccolo tubo con [-]? all'estremità, lungo circa una oncia e mezza. Inoltre, vi è un disco con forame rettangolare che non pare appartenente alla lanterna, ha di diametro circa un'oncia e mezzo. *Inv. Fiorelli*, 72070–72074. *Comments*: The object is quite probably the same that Falkener also mentions among the finds from R6. *Functional category*: Instrument, lighting.

132 Glass bottle

AC IV, 72, “una grossa boccia di forma cilindrica, alta circa un palmo con manico”; *PAH II*, 460, “una grande boccia di forma cilindrica dell'altezza di circa un pal. col suo manico”; Falkener, 49, “two large glass bottles about ten inches and a foot diameter”; Dwyer 1982, 31, vii. *Present location*: MANN *Reg. Im.* 22.7.1847, *SG* 2803 signed at the margin. May be *SG*, *Vetri*, 2802, “gran boccia”, *Inv. Fiorelli*, 12902, “altra alt. mill. 300, diam. mill. 160”. Not located. *Dimensions*: Probably H ca. 30.0; D 16.0 (*Inv. Fiorelli*). Description: Falkener writes that the bottle was “surrounded by the matrices of wicker baskets, a portion of which I cast in plaster of Paris”. *Comments*: Probably a one-handled cylindrical storage bottle Isings 51. *Functional category*: Vessel, storage.

133 Glass bottle

AC IV, 72, “un'altra della stessa foggia, alta pal. 1 1/5”; *PAH II*, 460, “altra anche di forma cilindrica, di altezza pal. 1 1/8”; Falkener, 49, “two large glass bottles about ten inches and a foot diameter”; Dwyer 1982, 31, viii. *Present location*: MANN *Reg. Im.* 22.7.1847, “altra pure di forma cilindrica alta un palmo e poco più”, *SG* 2804 signed at the margin. May be *SG*, *Vetri antichi*, 2803 (numbers confused with the preceding object), “altra boccia senza ornamento, anche di forma cilindrica, di altezza palmo uno ed un quinto”. Could be *inv. Fiorelli*, 12034. Not located. *Dimensions*: H 31.7 (*PAH*). *Comments*: Probably a one-handled cylindrical storage bottle Isings 51. *Functional category*: Vessel, storage.

R7 CUBICULUM

The second cubiculum opening onto the atrium to the left, R7, is one of the most puzzling areas of the house with regards to its finds.¹⁵ Falkener gives only an approximative list of its finds, including a candelabrum (Cat. 134) ‘in one angle of the room’, a culinary vessel, glass vases, fragments of terracotta (Cat. 135), and bones of birds (Cat. 136), referring the latter two back to the early report by Panofka in the *Bullettino Archeologico Napoletano*.¹⁶ Panofka's report mentions pottery fragments and mutton bones, “Ivi giacevano dei frammenti di terra cotta e delle ossa di agnello”. The *PAH* does not refer to this room at any point, and a matching group of finds has not appeared anywhere. Even if the pottery shards and bones may not have been noted, the candelabrum, as a large bronze object, would certainly have been inventoried. The finds will therefore be included here with question marks.

Furthermore, Falkener mentions, for the date March 26, the finding of two amphorae with inscriptions “on level of ceiling of second cubiculum on left” (Cat. 137–138). The *PAH* does not contain any report of these amphorae, nor record that any excavations were carried out on this day.

134 Bronze candelabrum?

Falkener, 50 “candelabrum”. *Functional category*: Instrument, lighting.

¹⁵ Panofka 1847 a, 131; Pancaldi 1848, 9–10; Falkener 1852, 49–50; Breton 1855, 300; Minervini 1854, 8–9; Minervini 1855, 54; *PPM IX*, 208–223; Tammisto – Kuivalainen 2008, 85–86.

¹⁶ Panofka 1847 a, 131.

135 Fragmentary vases?

Falkener, 50, “a culinary vessel, as well as several glass vessels”, “fragments of terracotta and bones of birds”, Panofka 1847 b, 131, “frammenti di terra cotta”. *Functional category*: Vessel (consumption, storage?).

136 Animal bones?

Falkener, 50, “bones of birds”; Panofka, “ossa di agnello”. *Comments*: Lamb bones may have been found in the room. *Functional category*: Organic.

March 26, 1st floor above R7, Falkener (p. 70), “on the level of the ceiling of the second cubiculum on the left”.

137 Terracotta transport amphora

Falkener, 70, “a large amphora, with obliterated inscription”. *Functional category*: Vessel, storage.

138 Terracotta transport amphora

Falkener, 70–71, “another amphora, broken, with the inscription – MES | AM. XVIII”; Minervini 1854, 21 = 1855, 85, “La terza anfora presenta la epigrafe MES | AM. XVIII. Pare che al numero dell’amfora si aggiunga la indicazione di qualche particolare vino. Ricordo il *Mesogites* di Plinio (lib. XIV, 7, 9); se pure dir non si voglia il *Messenium*, che potè in tal guisa denominarsi in vece del più solito epiteto di *Mamertinum*.”; *CIL* IV 2592, *MES(OGITEN?) / AM(PHORARUM) XVIII*. *Functional category*: Vessel, storage.

R8 ALA

The excavation of the lavishly decorated right ala R8 was started on April 14, but completed only a month later, on 17 and 18 May.¹⁷ Falkener lists in total nine finds from the room (p. 55, and n.). According to the *PAH* (p. 461–462), the greater part of the excavation of this room, ‘nell’ala dritta del tablino’, took place on April 14, for which there are three finds mentioned (the Bes statuette, an ornament for furniture, a human cranium). Additionally, a terracotta gutter with a lion head (Cat. 226) is mentioned, although according to Falkener this was found in the tablinum, and is consequently located in this Catalogue with the tablinum finds. According to the *PAH* (p. 464), on 17 May the floors of ala R8 and triclinium R16 were cleared to the last stratum of lapilli, during a special show excavation in the presence of the Prince of Bayer. A further four objects are placed in this room by Falkener (plate, shovel, ring, hinge: Cat. 142, 143, 145, 146). There is a discrepancy between the descriptions of the fifth find (Cat. 144), which is a tweezer according to the *PAH*, but a small vase according to Falkener. The clearance of the floors continued the following day, May 18, with the discovery of another hinge (Cat. 147), completing the nine finds mentioned in Falkener’s list.

Another mix-up concerns the finds from ala R8 and tablinum R15. Panofka speaks of another large luxurious room, with an entrance from the tablinum (thus presumably ala R8), but is actually describing the tablinum itself.¹⁸

April 14**139** Glazed terracotta statuette of Bes I.2.10

AC IV, 73, “I frammenti di una piccola statua raffigurante un cercopitaco bifronte con patina verde-bronzi-no”; *PAH* II, 461–462, “alcuni frammenti di una piccola statua rappresentante un Cercopiteco bifronte, di patina verde bronzino”; Falkener, 55, “some fragments of a terra-cotta statue, representing a bicipital monkey

¹⁷ *PAH* II, 461–462; Panofka 1847 a, 136; Avellino 1848, 7–8; Falkener 1852, 54–55; Minervini 1854, 10; 1855, 54; Breton 1855, 299–300; Dwyer 1982, 31; *PPM* IX, 224–240; Tammisto – Kuivalainen 2008, 86–88.

¹⁸ Panofka 1847a, 136.

of a green bronze coloured patina”; Minervini 1854, 21, “alcuni frammenti di una statuetta rappresentante una scimmia bifronte di color verde”, tav. IV, 12 = 1855, 84 “doppio pateco”. *Present location*: MANN *Reg. Im.* 22.7.1847, “frammento di una piccola statuetta rappresentante un cercopiteco bifronte”, *SG* noted at margin. *SG*, *Terracotte*, 5259, “piccola statuetta frammentata e restaurata alla meglio, rappresentante un cercopiteco bifronte di patina verde bronzino sopra base.” *Inu. Fiorelli*, 22589. *Comments*: A curious duplication of this object occurs in the catalogue of Minervini. As indicated above, he describes among the terracotta statues (1854, 21) a monkey with two faces, ‘scimmia bifronte’, clearly identical with the object mentioned above in the *PAH* and Falkener. However, he also mentions among the glass objects “un piccolo tubo al di sopra di una testa Silenica di pasta vitrea, da noi pubblicato nella tav. IV fig. 12”. In this figure, it is clearly the same image of the green-glazed Bes that is illustrated. The rectangular tube above its head is better conserved in the image than in its present state. The possibility remains that initially two distinct objects were found, but one was lost early on, and its description confused with the other. *Functional category*: Object of art/plastic figure/religious.

140 Bronze ornament for furniture

AC IV, 73 = *PAH* II, 462, “un ornamento di mobile con frammento di legno carbonizzato al di dentro”; Falkener, 55, n., “an ornament of furniture, with carbonized wood inside”; Dwyer 1982, 31, ii. *Present location*: *Reg. Im.* 22.7.1847, *SG* noted at margin. *SG*, *Bronzi minuti*, 8307, “un ornamento di mobile di bronzo di forma cilindrica con lastra prominente, il tutto lungo circa once quattro”. Not located. *Dimensions*: L 8.8 (*SG*). *Comments*: The *SG* has the most accurate description of the object, characterizing it as a cylindrical piece with a ‘prominent plate’ attached, and carbonized wood inside. It is not possible to identify its typology further than an ornamental ending of a piece of furniture. *Functional category*: Fixture, furniture.

141 Human bones

AC IV, 73 = *PAH* II, 462, “delle ossa umane carbonizzate, tra le quali la parte inferiore della bocca con pezzo di pane aderente”; Panofka 1847 a, 136, “un’altro scheletro”, Falkener, 55, “human skeleton”, De Carolis et al. 1998, 94, cat. 190. *Present location*: MANN *Reg. Im.* 22.7.1847, “ossa umane carbonizzate”. Not located. *Comments*: probably belongs together with the human skull that Falkener attributes to the atrium (Cat. 27). *Functional category*: Organic.

May 17, “si sono sono puliti dal lapillo che li copriva i pavimenti dell’ala destra, e del triclinio”.

142 Bronze plate

AC IV, 74 = *PAH* II, 465, “un piatto con alto bordo, del diametro di pal. 1”; Falkener, 55, “plate with raised border, ten inches diameter”. *Present location*: MANN *Reg. Im.* 22.7.1847, *SG* noted at margin. *SG*, *Bronzi minuti*, 8326, “un piatto di bronzo con alto bordo del diametro di palmo uno, alto circa once due”. Not located. *Dimensions*: D 26.5; H 4.4 (*SG*). *Comments*: A low bronze plate with a high, probably vertical rim, corresponding most closely to type Tassinari O1000 (teglie), with horizontal base and vertical wall, sometimes out-turned rim. The category contains utilitarian, not cast or decorated vessels, that probably primarily served as kitchen ware. *Functional category*: Vessel, cooking.

143 Bronze shovel

AC IV, 74, “una paletta con manico”; *PAH* II, 465, “una paletta col suo manico”; Falkener, 55, “fireshovel”; Minervini 1854, 20, “una paletta da fuoco” = 1855, 82. *Present location*: MANN *Reg. Im.* 22.7.1847, “paletta col suo manico”, *SG* noted at margin. *SG*, *Bronzi minuti*, 8327, “una paletta con suo manico ornato di fogliami, lunga once dieci e tre quinti”. Not located. *Dimensions*: L 23.3 (*SG*). *Comments*: The *SG* 8327 is written in *Reg. Im.* In the *Inventario SG* this piece is described as decorated with vegetal ornaments. Decorated small shovels are relatively rare finds. In Anna Rocco’s early catalogue of MANN bronzes, published by Nella Castiglione Morelli (2017, 217), of the five shovels listed only one is decorated with such ornaments. Rocco has erroneously given the shovel the *SG* inv. number 8441 – this number in *Bronzi minuti* is actually the *modius* from the House of Marcus Lucretius. However, the decorated, rectangular shovel *inv. Fiorelli* 76623, which she describes as resting on four small feet, is of identical length, 23.3 cm, and may indeed be the one from the

house. *Functional category*: Instrument, heating. A use in the kitchen or in ritual, as incense burners, has also been suggested for such utensils.

144 Bronze tweezer III.2.7

AC IV, 74; “una piccola pinzetta”; *PAH* II, 465, “una piccola pinsetta”. *Present location*: MANN *Reg. Im.* 22.7.1847, *SG* noted at margin. *SG*, *Bronzi minuti*, 8328, “una piccola pinsetta, lunga once tre e quattro quinti”. *Inv. Fiorelli*, 77847, “altra simile, ma con le due punte rivolte nel medesimo senso. Lunga mill. 84.” *Dimensions*: 8.4 (*Inv. Fiorelli*); 10.4 (*SG*). *Comments*: Falkener, 55, mentions instead of ‘piccola pinsetta’ a ‘small vase’, by error or misinterpretation. *Functional category*: Instrument. medical/cosmetic.

145 Bronze ring

AC IV, 74 = *PAH* II, 465, “un anello”; Falkener, 55, “ring”. *Present location*: MANN *Reg. Im.* 22.7.1847. Not located. *Functional category*: Fixture, unknown function.

146 Bronze strap hinge

AC IV, 74, “un arpione”; *PAH* II, 465, “una sciba”; Falkener, 55, “two hinges for folding doors”. Cf. the following day, “una grande sciba”. *Present location*: MANN *Reg. Im.* 22.7.1847. Not located. *Functional category*: Fixture, closure (door).

May 18, *PAH* II, 465, “essendosi proseguito lo sgombramento del lapillo da’ pavimenti di ieri palesati, si è rinvenuto nell’ala dritta”. On the floor level.

147 Bronze strap hinge

AC IV, 74, “un grande arpione”; *PAH* II, 465, “una grande sciba”; Falkener, 55, see above the preceding day, “two hinges”. *Present location*: MANN *Reg. Im.* 22.7.1847. Not located. *Functional category*: Fixture, closure (door).

R9 ALA (R10)

The *PAH* (p. 465) reports that the left ala R9¹⁹ which provides access to the kitchen area, and the contiguous unadorned and servile room R10, were excavated together on May 22, in the presence of Queen Cristina of Spain, “si è eseguito uno scavo nell’ala sinistra del tablino della nota casa delle Sonatrici, e nella stanza contigua che è al lato della scala.” According to Falkener (p. 53–54), six objects were found in the ala: a bronze patera with Medusa head (Cat. 148), two pivot hinges (Cat. 150–151), and three strap hinges (Cat. 152–154). The major difficulty in attributing finds to the rooms is caused by the fact that the *PAH*, in addition to the aforementioned six objects, lists nine objects that Falkener instead attributes to other rooms, including a group of six objects from the upper triclinium R25 with the three urcei (Cat. 343–345), an unguent bottle (Cat. 348), and two plates with olives (Cat. 349–350). Similarly, the terracotta altar with a statue of Minerva (Cat. 272–273) were found, according to Falkener, in the garden area; this may be confirmed by the vicinity in the list of the marble statue of Cupid on a dolphin, as this is also more plausibly from the garden area. The iron scraper listed together with the preceding items (Cat. 155) is attributed by Falkener to the kitchen complex. Furthermore, the bronze ornament for furniture with a human figure (Cat. 149) is not mentioned by Falkener.

Panofka reports a bronze vessel, ‘un vaso di bronzo fu ivi scoperto’.²⁰ Breton lists three hinges and the Medusa-patera in this room.²¹ He also gives a separate citation from the *PAH*, on May 22, for a special excavation partly in this room, mentioning, without provenience, a ‘*terme*’ in bronze, referring to the figural furniture

¹⁹ *PAH* II, 465; Avellino 1848, 34; Panofka 1847a, 131; Falkener 1852, 53; Minervini 1854, 10–11; Breton 1855, 300. 307; *PPM* IX, 241–247; Tammisto – Kuivalainen 2008, 88.

²⁰ Panofka 1847a, 131.

²¹ Breton 1870, 390. 397.

applique in bronze, the statue of Cupid and a dolphin, the altar with a statuette of Minerva, and the plate and bowl with olives. Further, describing the room, he mentions as finds ‘divers ustensils, plusieurs moules à pâtisserie et un fourneau de fer de forme cylindrique’. This last piece of information is curious, as it does not appear either in the *PAH* or in Falkener. Such ‘forme di pasticceria’ are not mentioned anywhere else. The cylindrical oven or brazier clearly alludes to the ‘caldaia with iron fornello’. This was found, according to Falkener, in the kitchen area, without mention of the ‘fornello’. The *PAH* lists the ‘caldaia’ with iron brazier (Cat. 215) among the confused finds of August 30.

May 22

148 Bronze patera with relief decoration and silver inlay II.1.3

PAH II, 465, “una patera col suo manico distaccato, nel fondo della quale evvi la testa di Medusa con giro di argento, entrambi distaccati”; Falkener, 53–54, “bronze patera with a head of Medusa in the center, surrounded by a silver ring, both detached”; Minervini 1854, 20, “tralle patere ricorderemo particolarmente quella, nel cui fondo vedesi la testa di Medusa con giro di argento, lavoro ad *empaestica*” = 1855, 82. *Present location*: MANN *Reg. Im.* 22.7.1847, erroneous *SG* 8338 signed at the margin. *SG*, *Bronzi minuti*, 8438, “patera di bronzo col suo manico nel fondo della quale evvi la testa di Medusa con giro di argento. Diametro once nove e mezzo, lunga al manico palmo uno e once tre”. *Inv. Fiorelli*, 73455. *Functional category*: Vessel, ablutions (religion/banquet?).

149 Bronze ornament for furniture

PAH II, 465, “un piccolo Termine, ornamento di mobile”; Dwyer 1982, 32, ii. *Present location*: MANN *Reg. Im.* 22.7.1847, erroneous *SG* 8330 signed at the margin. Probably *SG*, *Bronzi minuti*, 8330, “un piccolo termine con figura giovanile ornata di veste con testa di Medusa e serpente, alto once cinque ed un quinto”. Not located. *Dimensions*: L 11.4 (*SG*). *Comments*: Not mentioned by Falkener, unless it is among the ‘portions of furniture’ from the garden area, p. 78, n. *Functional category*: Fixture, furniture.

150–151 Two bronze pivot hinges

PAH II, 465, “due bilici di porta, uno de’quali privo di piastra”; Falkener, 53, “two cylinder-and-socket hinges”. *Present location*: MANN *Reg. Im.* 22.7.1847. Not located. *Functional category*: Fixture, closure (structural door).

152–154 Three bronze strap hinges

PAH II, 465, “tre scibe, due di esse piccolissime”; Falkener, 53, “three valve hinges, two of which were very small”. *Present location*: MANN *Reg. Im.* 22.7.1847. Not located. *Functional category*: Fixture, closure (door).

R11–14 SERVILE QUARTERS/KITCHEN AREA

The main excavation phase of these four undecorated servile rooms, including the latrine R13 and the kitchen R14,²² took place on August 12–13. Further work was done at the same time as the whole posterior part of the house, on August 30. Some isolated finds in the marginal areas had been recovered earlier in May 22 and June 19. Falkener lists 37 items, plus ‘several vases and vessels’ in bronze, as found in the servile quarters around the kitchen. The first object that can be found both in the *PAH* and in Falkener’s lists is an iron scraper (Cat. 155) that appeared, according to the *PAH*, on May 22, during the excavations of the ala R9–R10. These rooms flank the servile quarters, so the find spot of the object is plausible. The next coinciding find, a marble mortar with its pestle (Cat. 156–157), came to light on June 9, when the main excavation was going on in the rooms around the garden. On August 12, a room allegedly “at the side of the house of the Sonatrici” was emptied, presumably the southernmost of the servile rooms, R11. At the considerable height of ca. 185 cm, ca. 15

²² Avellino 1848c, 35; Falkener 1852, 81–82; Bechi 1852, 10; Breton 1855, 300; Minervini 1854, 11; Dwyer 1982, 32–36.

objects, which match Falkener's note (Cat. 158–161, 163–164, 166–167, 176–178, 181–184), were found. Another 10 finds not mentioned by Falkener were unearthed on the same day, including a bronze vessel (Cat. 165) that could be one of his generic 'vases and vessels in bronze'. Furthermore, three lock plates, a bronze handle, a lantern wick, and three decorative bronze nails were found (Cat. 168–175). A further discrepancy concerns the 'due vasettini' in terracotta (Cat. 179–180), not explicitly cited in Falkener's list, but perhaps identical with his 'two cups' in glass. The following day, August 13, saw more work concentrated on the servile rooms, quite probably in the adjoining R12 or R14; once again, the considerable height of ca. 158.7 cm was given as the level of the finds. The *PAH* lists 16 objects for this day, described by Falkener as kitchen finds, among which were the important group of nine terracotta figurines (Cat. 194–200, 209–210), and furthermore fourteen items not mentioned by him as deriving from here or mentioned in any other context (Cat. 179–180, 186, 189–192, 201–205, 212–213), including the female terracotta statuette bust (Cat. 200). A glass cup (Cat. 193) might alternatively be identical with the aforementioned 'two cups' of Falkener. The list of fairly securely attributed finds ends here.

The following finds were made on August 30, sort of a *dies horribilis* for finds, as a specifically 'prepared' excavation was conducted in the presence of the Royal Family, resulting in the most extensive finds list of the entire excavation period, deriving at least from three completely separate areas: the servile quarters, various rooms in the upper area of the house at entrance IX 3, 24 (R29, R32, R33) and House IX 3, 2: 'Avendo la prelodata M.S. ordinato, che si cavassero le stanze preparate antecedentemente per lo scavamento'. During these next two excavation days, work went on amongst the earth already moved, which still contained finds. Among this multitude of finds, the only three items explicitly mentioned by Falkener as coming from the kitchen area are a bronze boiler, 'caldaia', with handles in dolphin form (Cat. 215), the 26 bone hinges (Cat. 216) and an ear-pick (Cat. 217). Excluding from the finds of this day those attributed by Falkener to other rooms or House IX 3, 2, the provenience of the remaining finds is naturally uncertain. One further find mentioned by Falkener, a bronze patera (Cat. 218), is probably the one mentioned among the finds of August 31.

Breton mentions among the kitchen finds "plusieurs moules à pâtisserie et un fourneau de fer de forme cylindrique", not documented earlier.²³ The rest of the finds made on August 30 and 31 that do not have a clear provenience have been listed at the end of the catalogue, in a separate section.

May 22

155 Iron scraper

PAH II, 465, "una raschiatoia"; Falkener 82, n., "iron grater"; Minervini 1854, 20, "due piccole pale destinate forse per raschiare il suolo (pala, σκάφη)" = 1855, 83. *Present location*: MANN *Reg. Im.* 22.7.1847, *SG* noted at margin. *SG*, *Bronzi minuti*, 8331, "una raschiatoia di ferro, ossidata, lunga once dieci". Not located. *Dimensions*: L 22 (*SG*). *Comments*: According to *PAH*, from R9–10, in 22 May; Falkener reports an 'iron grater' from the kitchen area. The object could plausibly have been found when excavating the door opening that connects R9 to R11. *Functional category*: Instrument, hardware tool (carpentry).

June 9

156–157 Marble mortar and pestle

AC IV, 75, "Un mortaio col pistello"; *PAH* II, 457, "un mortaio col suo pistello"; Falkener, 82, n., "a marble mortar and pestle". *Present location*: MANN *Reg. Im.* 22.7.1847, "mortajo col suo pistillo", *SG* 1623 signed at the margin. *SG*, *Marmi*, 1623, "mortajo in marmo greco, diametro palmo uno"; and 1624, "Dito pollice in marmo greco ad uso di pistello del precedente mortajo lungo once tre". Not located. *Dimensions*: D (mortar) 26.4; length (pestle) 6.6. *Comments*: The *PAH* lists these among the finds from the garden, in particular its SE corner. *Functional category*: Vessel, food preparation.

²³ Breton 1855, 300.

August 12, “In una stanza che fiancheggia la indicata casa delle Sonatrici all’alt. di circa pal. 7, ed alle ore 22 circa sonosi raccolti i seguenti oggetti.” P. 469. Probably R11. Upper layers: the indicated height is ca. 185 cm.

158 Bronze weight

PAH II, 469, “un peso o romano di bilancia di forma oblonga alto 3/10 di pal.”; Falkener, 82, n., “two weights of balance”. *Present location*: MANN. *SG*, *Bronzi minuti*, 2675, “...alto once quattro ed un quinto”. Not located. *Dimensions*: L 7.9 (*PAH*); 9.2 (*SG*). *Functional category*: Instrument, weighing.

159–160 Two bronze keys

PAH II, 469, “due chiavi, una piccola e l’altra grande”; Falkener 1852, 82, n., “two keys”. *Present location*: MANN; *SG*, *Bronzi minuti*, 2673–2674, “Due chiavi di bronzo uno grande uno piccolo. La prima lunga once due e la seconda once uno e mezzo.” Not located. *Dimensions*: L ca. 4.4 and 3.3 (*SG*). *Functional category*: Fixture, closure.

161 Bronze weight

PAH II, 469, “un piccolo peso di forma circolare”; Falkener 1852, 82, n., see above, for two weights; “un piccolo peso”, Minervini 1854 = 1855, 82. *Present location*: Not located. *Functional category*: Instrument, weighing.

162 Bronze vessel

PAH II, 469, “un vasettino col manico e fondo dissaldato”: *Present location*: MANN. *SG*, *Bronzi minuti*, 8451, “vasettino di bronzo col manico e fondo dissaldato. Alto col manico quattro decimi e sei centesimi”. Not located. *Dimensions*: H 12.2 (*SG*). *Functional category*: Vessel, unknown function.

163 Bronze ring and furniture decorations

PAH II, 469, “un anello ed altri due ornamenti di mobile, ad uno de’ quali sono infissi due chiodi”; Falkener 1852, 82, n., “rings and ornaments of furniture”; Dwyer 1982, 33, iv. *Present location*: Not located. *Functional category*: Fixture, furniture.

164 Bronze candelabrum plate

PAH II, 469, “una coppa di candelabro”; Falkener 1852, 82, n., “a candelabrum top”; Dwyer 1982, 33 iii. *Present location*: Not located. *Functional category*: Instrument, lighting.

165 Bronze vessel

PAH II, 469, “un vasetto molto consunto”; Dwyer 1982, 33, vii. *Present location*: Not located. *Functional category*: Vessel, unknown function.

166 Bronze mirror III.2.9

PAH II, 469, “uno specchio circolare del diametro di 4/10 di pal.”; Falkener 1852, 82, n., “a mirror, 3 ins. in diameter”; Minervini 1854, 20, “(due) specchi, uno dei quali circolare con la superficie riflettente assai ben conservata” = 1855, 82. *Present location*: MANN *Reg. Im.* 4.10.1847. *SG*, *Bronzi minuti*, 8530, “uno specchio circolare di bronzo del diametro di quattro decimi e cinque centesimi”. *Inu. Fiorelli*, 74915, “Altro circolare tornito nella periferia e nel centro. D. mm 120. Materia metallica.” *Dimensions*: D 12 (*inv. Fiorelli*); D 11.9 (*SG*). *Functional category*: Instrument, cosmetic.

167 Bronze lock plate

PAH II, 469, “una mappa di serratura”; Falkener 1852, 82, n., “a lock”. *Present location*: Not located. *Functional category*: Fixture, closure.

168–170 Three bronze lock plates

PAH II, 469, “tre scudi di mascatura”. *Present location*: Not located. *Functional category*: Fixture, closure.

171 Bronze handle

PAH II, 469, “un manico di mobile”. *Present location*: Not located. *Functional category*: Fixture, furniture.

172 Lantern wick

PAH II, 469, “uno stoppino di lanterna”. *Present location*: Not located. *Functional category*: Instrument, lighting.

173–175 Three bronze nails

PAH II, 469, “tre piccoli chiodi tutti per ornamenti di mobile”. *Present location*: *Reg. Im.* 4.10.1847. Not located. *Functional category*: Fixture.

176 Glass unguent bottle

PAH II, 469, “una bottiglia a palla di altezza ½ pal. circa”; Falkener 1852, 82, n., “a glass bottle, 4 ins. high”; Dwyer 1982, 34, xi. *Present location*: MANN *Reg. Im.* 4.10.1847, erroneous *SG* 2808 noted at margin. Not located. *Dimensions*: H ca. 13.2 (*PAH*). *Comments*: Probably a large pear-shaped *unguentarium* Scatozza 42/49. *Functional category*: Vessel, medical/cosmetic.

177 Glass bottle

PAH II, 469, “altra bottiglia bislunga con collo corto ad un manico, di alt. ½ pal.”; Falkener 1852 82, n., “a long bottle with a short neck”; Dwyer 1982, 34, x. *Present location*: MANN *Reg. Im.* 4.10.1847, “altra bislunga a collo corto”, *SG* noted at margin. *SG*, *Vetri antichi*, 2856. Not located. *Dimensions*: H ca. 13.2. *Comments*: Probably a one-handed cylindrical storage bottle Isings 51. *Functional category*: Vessel, storage.

178 Glass unguent bottle

PAH II, 469, “una caraffinetta di alt. 3/10 di pal.”; Falkener 1852, 82, n., “a long-necked bottle”; Dwyer 1982, 34, xii. *Present location*: MANN *Reg. Im.* 4.10.1847. Not located. *Dimension*: H ca 7.9 (*PAH*). *Functional category*: Vessel, medical/cosmetic.

179–180 Two terracotta mugs

PAH II, 469, “due vasettini entrambi privi di manico”; Dwyer 1982, 36, xxvi. *Present location*: MANN *Reg. Im.* 4.10.1847. *SG*, *Terrecotte*, 5286 or 5292? *Inv. Fiorelli*, 22876–22882? *Comments*: The *PAH* states that the handles are missing, and thus the form originally had handles. Small terracotta vases with handles most probably refer to pareti sottili jugs. Falkener mentions ‘two cups’ seemingly under the heading of glass objects. It is possible that he has confused and combined here the the *PAH* references ‘due vasettini’ in terracotta and ‘piccolissima coppa’ in glass. Most probably two thin-walled one-handed mugs. *Functional category*: Vessel, culinary consumption.

181 Iron key

PAH II, 469, “una chiave”; Falkener 1852, 82, n., “key”. *Present location*: MANN *Reg. Im.* 4.10.1847. Not located. *Functional category*: Fixture, closure.

182 Iron bolt/bar

PAH II, 469, “un bastone lungo pal 2. e 6/10, forse serratura di porta”; Falkener 1852, 82, n., “bolt”. *Present location*: MANN *Reg. Im.* 4.10.1847. Not located. *Dimensions*: L 68.8 (*PAH*). *Functional category*: Fixture, closure (door).

183 Stone weight

PAH II, 469, “un piccolo peso circolare del diametro di 2/10 di pal.”; Falkener 1852, 82, n., “weight”. *Present location*: MANN *Reg. Im.* 4.10.1847. Not located. *Dimensions*: D 5.3 (*PAH*). *Functional category*: Instrument, weighing.

184 Stone altar

PAH II, 469, “un ara alta ½ palmo”; Falkener 1852, 82, n., “altar”; Dwyer 1982, 32, i. *Present location*: MANN *Reg. Im.* 4.10.1847. Not located. *Dimensions*: H 13.2 (*PAH*). *Functional category*: Furniture (cult, religion).

August 13, “Si è posto mano agli scavi alle ore 9, lavorandosi ne’compresi che fiancheggiano la casa delle Sonatrici, onde isolare le mura dall’urto delle terre. Alle ore 21 italiane si è rinvenuto all’alt. di circa pal. 6 in uno de’compresi di sopra indicati.” Should be either R13 or R14, at the height of 158.7 cm.

185 Bronze strainer II.1.4

PAH II, 469, “cola-liquidi di forma circolare, del diametro di circa 9/10 di pal.”; Falkener 1852, 82, n., “strainer”; Dwyer 1982, 33, vi. *Present location*: MANN *Reg. Im.* 4.10.1847, *SG* noted at margin. *SG*, *Bronzi minuti*,

2670, “cola liquidi di forma circolare, del diametro di once undici e mezzo”. *Inv. Fiorelli*, 77603, “Colatojo a forma di scodella senza manici con fori che presentano nel mezzo dei cerchi a vari giri, ed intorno dei semicerchi. E’ alquanto contorto, ed ha della cenere aderente. Diam. mill. 220 alt mil. 75.” *Dimensions*: D 22.9 (SG). H 7.5; D 22.0 (*Inv. Fiorelli*). *Functional category*: Vessel, pouring (wine, banquet service).

186 Bronze unguent bottle

PAH II, 469, “un’oleario di alt. 3/10 di pal. privo di manico”; Dwyer 1982 34, ix. *Present location*: MANN *Reg. Im.* 4.10.1847, “Bronzo. Ungentario alto 5/10”. *SG* noted at margin. *SG*, *Bronzi minuti*, “Un unguentario alto once cinque e quattro quinti”. Not located. *Dimensions*: H ca. 7.9 (*PAH*); ca. 13.5 (*Reg. Im.*); ca. 12.76 (*SG*). *Comments*: Considering its short height as given in the *PAH*, and the name used in *SG*, ‘ungentario’, this oil-vase with one (lost) handle this may be an *aryballos*, Tassinari category F. The heights given in *Reg. Im.* and *SG* are taller, but not impossible for such an identification, as examples cited by Tassinari reach up to 12 cm. *Functional category*: Vessel, cosmetic.

187 Bronze funnel

PAH II 469, “un imbuto in due pezzi, di cui la parte superiore di forma circolare è del diametro di circa 1/2 pal.”; Falkener 1852, 82, n., “funnel”. *Present location*: MANN *Reg. Im.* 4.10.1847, “un imbuto in due pezzi”. *Dimensions*: D 13.2 (*PAH*). *Comments*: Bronze funnels are not common among Pompeian finds, and they must have often been made of other materials. According to Tassinari (1993, I, 88–89, II, 197–199), there are only 18 examples of category R (funnels) in the Pompeii archaeological storerooms. *Functional category*: Vessel, pouring.

188 Bronze strap hinge

PAH II, 469, “una sciba”, Falkener 1852, 82, n., “a hinge”. *Present location*: MANN *Reg. Im.* 4.10.1847. Not located. *Functional category*: Fixture, closure (door).

189–190 Bronze fragments

PAH II, 469, “un chiodo, ed altro pezzo rettangolare per ornamento di mobile”; Dwyer 1982, 33, v. *Present location*: MANN *Reg. Im.* 4.10.1847. Not located. *Functional category*: Fixture, furniture.

191 Bronze lock

PAH II, 469, “un lucchetto”. *Present location*: MANN *Reg. Im.* 4.10.1847. Not located. *Functional category*: Fixture, closure (container?).

192 Glass bottle

PAH II, 469, “una grossa carafinetta a palla rotta nel collo”; Dwyer 1982, 34, xiii. *Present location*: MANN *Reg. Im.* 4.10.1847, “una caraffinetta a palla rotta nel collo”. *SG*, *Vetri antichi*, 2894 or 2854, “carafinetta di altezza tre decimi di palmo”. *Dimensions*: 7.9? (*SG*). *Functional category*: Vessel, medical/cosmetic.

193 Glass cup II.2.9

PAH II, 469, “una piccolissima coppa circolare di 15/20 di diametro”; Falkener 1852, 82, n., “two (glass) cups”. *Present location*: MANN *Reg. Im.* 4.10.1847, “una piccolissima coppa, erroneous *SG* 2809 noted at margin. Diam. 3/10 di pal.” *SG*, *Vetri antichi*, 2808, “piccolissima coppa circolare di diametro tre ventesimi di palmo”. *Inv. Fiorelli*, 13633. *Functional category*: Vessel, culinary consumption.

194 Terracotta statuette (Standing naked Venus) I.2.4

PAH II, 469, “una statuetta di Venere anadiomene dell’alt di 6/10 di pal. compresa la base; presso la sua gamba sinistra evvi una piccola erma di Priapo”; Falkener 1852, 82, n., “statue of Venus Andymene, with a statue of Priapus near her left leg”; Minervini 1854, 21, “statuetta di Venere con da presso un Panisco” = 1855, 84. *Present location*: MANN *Reg. Im.* 4.10.1847, *SG* noted at margin. *SG*, *Terrecotte*, 5264. *Inv. Fiorelli* 20316. *Functional category*: Object of art/plastic figure/cult.

195 Terracotta statuette (standing draped female) I.2.1

PAH II, 469, “altra statuetta dell’alt. 6/10 di pal. rappresentante una figura muliebre avvolta nella sua veste”; Falkener 1852, 82, n., “a female enveloped in her mantle”; Minervini 1854, “alcune figurine virili o muliebri in parte frammentate”; Dwyer 1982, 35, xvii, fig. 17. *Present location*: MANN *Reg. Im.* 4.10.1847, *SG* noted

at margin. *SG, Terrecotte*, 5262, “Statuetta muliebre di terra cotta, avvolta nella sua veste, dell’altezza di mezzo palmo”. *Inv. Fiorelli*, 20638. *Functional category*: Object of art /plastic figure.

196 Terracotta statuette

PAH II, 469, “altra statuetta simile alla precedente dell’alt. ½ pal.”; Falkener 1852, 82, n., “another similar, 4 ins. High”; Von Rohden, 70; Dwyer 1982, 35, xviii. *Present location*: MANN *Reg. Im.* 4.10.1847, *SG* noted at margin. *SG, Terrecotte*, 5248. *Inv. Fiorelli* 20632, “statuetta dell’altezza di 0,132 rappresentante una figura muliebre avvolta nella sua veste”. *Dimensions*: H 13.2. *Comments*: Similar architectural applique as the above Cat. 195. *Functional category*: Object of art/plastic figure. Probably part of architectural ceiling decoration.

197 Terracotta statuette (gladiator) I.2.7

PAH II, 469, “altra statuetta d’un Gladiatore combattente dell’alt. di circa 6/10 di pal.”; Falkener 1852, 82, n., “another of a Gladiator”; Minervini 1854, 21, “la figurina di un gladiatore” = 1855, 84. *Present location*: MANN *Reg. Im.* 4.10.1847, *SG* noted at margin. *SG, Terrecotte*, 5270. *Inv. Fiorelli*, 20257. *Functional category*: Object of art/plastic figure.

198 Terracotta statuette (standing draped male) I.2.6

PAH II, 469, “altra statuetta di una figura virile alta 6/10 di pal.”, Falkener 1852, 82, n., “another of a male figure”. *Present location*: MANN *Reg. Im.* 4.10.1847, *SG* noted at margin. *SG* 5271. *Inv. Fiorelli*, 20258. *Functional category*: Object of art/plastic figure.

199 Terracotta statuette group (sedan chair porters) I.2.8

PAH II, 469, “un gruppo figurante due servi che trasportano una cassa, con dentro una figura dell’alt. ½ pal.”, Falkener 1852, 82, n., “a group of two slaves bearing a box, in which is a figure”; Minervini 1854, 21, pl. IV 2, “due uomini portando una lettiga con dentro un fanciullo” = 1855, 84. *Present location*: MANN *Reg. Im.* 4.10.1847, *SG* noted at margin. *SG, Terrecotte*, 5265. *Inv. Fiorelli*, 20255. *Functional category*: Object of art/plastic figure.

200 Terracotta statuette (female bust) I.2.5

PAH II, 469–470, “un busto muliebre, forse di una imperatrice di alt. ½ pal. circa”, Minervini 1854, 21, “altro busto femminile” = 1855, 84. *Present location*: MANN *Reg. Im.* 4.10.1847, *SG* noted at margin. *SG, Terrecotte*, 5247. *Inv. Fiorelli*, 21198, “busto muliebre forse di un imperatrice alto 0,132”. *Functional category*: Object of art/plastic figure.

201 Two terracotta rings

PAH II, 470, “due anelli”. *Present location*: MANN *Reg. Im.* 4.10.1847, “due anelli di terra cotta”, *SG* noted at margin. *SG, Terrecotte*, 5285, “due anelli”. Not located. *Functional category*: Unknown.

202 Terracotta mug

PAH II, 470, “un pignatto ad un manico di alt. circa ½ pal.” *Present location*: MANN *Reg. Im.* 4.10.1847. Not located. *Dimensions*: H 13.2 (*PAH*). *Comments*: The vessels may be a thin-walled one-handed mug. *Functional category*: Vessel, culinary consumption.

203 Terracotta pan

PAH II, 470, “un tegame circolare del diametro 8/10 di pal.” *Present location*: MANN *Reg. Im.* 4.10.1847. Not located. *Dimensions*: D 21.6 (*PAH*). *Comments*: This vessel may be a small cooking-ware pan or kettle. *Functional category*: Vessel, cooking.

204 Terracotta jug

PAH II, 470, “una piccolissima langella ad un manico, di alt. circa 3/10 di pal.” *Present location*: MANN *Reg. Im.* 4.10.1847, “piccola langella rotta nel manico alta 3/10 di pal.” *SG, Terrecotte*, 5242, “piccolissima langella, ad un manico, rotto nel labbro, di altezza circa tre decimi di palmo”. *Dimension*: H ca 7.8 (*PAH, SG*). *Comments*: The word ‘langella’ may refer to a one-handed *lagynos* shaped jug, with narrow neck and wider body. However, the indicated height is very small, almost miniaturistic for such a jug. *Functional category*: Vessel, pouring.

205 Terracotta lid

PAH II, 470, “un coverchio di pignatto”. *Present location*: MANN *Reg. Im.* 4.10.1847. Not located. *Functional category*: Vessel, cooking/storage.

206 Terracotta lamp with two nozzles

PAH II, 470, “una lucerna a due lumi senza manico”, Falkener 1852, 82, n., “three lamps” (one of three). *Present location*: MANN *Reg. Im.* 4.10.1847. *SG, Terrecotte*, 5230. *Inv. Fiorelli*, 19911, “lucerna a due lumi senza manico”. Not located. *Comments*: A *bilychne* lamp. *Functional category*: Instrument, lighting.

207 Terracotta lamp III.1.2

PAH II, 470, “altra lucerna anche priva di manico, con sopra la figura di un cavallo”, Falkener 1852, 82, n., “three lamps, one of which has a horse at top”; Minervini 1854, 21, “lucerna...la quale offre al di sopra la immagine di un cavallo” = 1855, 85; Dwyer 1982, 36, xxv. *Present location*: MANN *Reg. Im.* 4.10.1847. *SG, Terrecotte*, 5221, “altra lucerna di terracotta priva di un manico con sopra la figura di un cavallo”. *Inv. Fiorelli*, 19904, “altra di terracotta priva di un manico con sopra la figura di un cavallo 0,079”. *Functional category*: Instrument, lighting.

208 Terracotta lamp

PAH II, 470, “altra simile lucerna”, Falkener 1852, 82, n., “three lamps”. *Present location*: MANN *Reg. Im.* 4.10.1847, erroneous *SG* 5276 signed at the margin. *SG, Terrecotte*, 5222, “altra simile lucerna”. Not located. *Functional category*: Instrument, lighting.

209 Terracotta statuette (twin Bacchic heads) I.1.9

PAH II, 470, “un frammento di due teste bacchiche”; Falkener 1852, 82, n., “a fragment with two Bacchic heads”; Minervini 1854, 21, “un bacchico bicipite frammentato” = 1855, 84. *Present location*: MANN *Reg. Im.* 4.10.1847. *SG, Terrecotte*, 5276, “frammento con due teste bacchiche”; *Inv. Fiorelli*, 24109, “frammento con due teste bacchiche”. *Functional category*: Object of art /plastic figure.

210 Terracotta statuette

PAH II, 470, “altro frammento d’una figura muliebre”; Falkener 1852, 82, n., “a fragment of female figure”; Von Rohden, 70; Dwyer 1982, 35, xix. *Present location*: MANN *Reg. Im.* 4.10.1847. *SG, Terrecotte*, 5283. *Inv. Fiorelli*, 20641, “frammento di una figura muliebre”. Not located. *Functional category*: Object of art /plastic figure.

211 Bone tessera

PAH II, 470, “una tessera circolare col numero VIII, del diametro di 1/10 di pal.”; Falkener 1852, 82, n., “a bone tessera, bearing No. VIII”; Minervini 1854, 20, “altra col num. XIII” = 1855, 84. *Present location*: MANN *Reg. Im.* 4.10.1847, “tessera di forma circolare col numero VIII del diam. 1/10 di pal.”, *SG* noted at margin. *SG, Bronzi minuti*, 2671, “tessera di osso di forma circolare col numero VIII del diametro di uno decimo di palmo.” Not located. *Dimensions*: D 2.6 (*PAH*). *Functional category*: Instrument, entertainment (gaming counter). There are three different readings for the numeral: VIII, VIII, or XIII.

212 Bone tesserae

PAH II, 470, “due pezzettini a forma di mandorle”, Minervini 1854, 20, “tessere... altre due a forma di mandorle” = 1855, 84. *Present location*: MANN *Reg. Im.* 4.10.1847, *SG* noted at margin. *SG, Bronzi minuti*, 2672, “due pezzettini di pietra (*sic*) a forma di mandorle. Alto ognuno due decimi di oncia, lunga quattro quinti di oncia.” Not located. *Dimensions*: Th 0.4; L 1.6 (*SG*). *Functional category*: Instrument, entertainment (gaming counter).

213 Bone spindle

PAH II, 470, “un piccolo verticchio”. *Present location*: MANN *Reg. Im.* 4.10.1847, “un piccolo vertecchio”. Not located. *Functional category*: Instrument, textile work.

214 Bone spoon

PAH II, 470, “un cucchiariino privo di manico del diametro di 6/20 di pal.”; Falkener 1852, 82, n., “a small spoon-bowl”; Dwyer 1982, 34, xv. *Present location*: MANN *Reg. Im.* 4.10.1847. Not located. *Dimensions*: D

7.8? (PAH). *Comments:* The indicated diameter, calculated from the Neapolitan foot at 26 cm, results in a diameter far too large for a spoon, and there must be an error. However, the fact that a diameter is given reveals that this was a spoon with a circular bowl. *Functional category:* Vessel for culinary consumption. Alternatively, this might also be a medical/cosmetic instrument.

August 30, Falkener 1852, 82, n., “several vases and vessels, 6 to 16 ins. diameter”.

215 Bronze boiler

AC IV, 161 = PAH II, 472, “una caldaia col coverchio, e a due manici figurante ognuno due delfini, uno de’ detti manici è dissaldato, l’altezza di detta caldaia è di pal. 1 3/5”; Falkener 1852, 82, n., “one of which was ornamented with two dolphins”; Minervini 1854, 20, = 1855, 82, “Tralle numerose caldaie son da ricordar due, conservate insieme co’loro fornelli di ferro: una non può distaccarsi dal suo fornello, a causa dell’ossidazione, che ne ha formato quasi un sol corpo. In questa i manichi sono formati ciascuno da due delfini, di cui s’intrecciano in alto le code.” *Present location:* MANN *Reg. Imm.* 22.7.1847, “Caldaja a due manici con coverchio figurante ognuno due delfini”, SG written at the margin. SG, *Bronzi minuti*, 8458, “Caldaja di bronzo col coverchio e due manici figurante ognuno due delfini. Si noti che la caldaja descritta e fermata in un fornello di ferro con molto lapillo aderente. L’altezza di detta caldaja e di palmo ed onces otto fino a manichi. Il fornello di ferro e alto palmo uno ed onces nove”. Not located. *Dimensions:* H 41.6 (PAH, SG). *Comments:* The vessel probably belongs to the category of large cylindrical water heaters with outturned rim, that Rocco (2017, 17, 246, fig. 3) classified as her type I (*milliarium*). No examples are present at Pompeii storerooms, where only the Tassinari category V, ‘caldaie’, and, in particular, type V 1000, ‘pentole con ventre troncoconico o cilindrico’, with rounded bottom, high cylindrical body, and narrow neck, often have on handle decorated with plastic (dolphin) figures, see Tassinari 1993, I, 102–105. Cf. a cylindrical boiler with figured handles, inside an iron heater in *Museo Borbonico* 1829, V, pl. LIX, 7, illustrated in Birzio Piroli Stefanelli 1990, 115, fig. 61. Cf. also *ibid.* 277, cat. 87, 216, fig. 194, a large boiler of type V 1000, with a similar handle formed of two dolphins with joined tails (inv. MANN 78720). *Functional category:* Vessel, cooking (heating water).

216 26 circular bone hinges

AC IV, 162 = PAH II, 472, “ventisei pezzetti circolari”; Falkener 1852, 82, n., “twenty-six pieces of circular bone”. *Present location:* MANN *Reg. Im.* 22.7.1847. SG, *Bronzi minuti*, 2685–2710, “Ventisei pezzi circolari di osso. Il più grande è lunga onces una il più piccolo mezz’oncia”. *Dimensions:* L 2.2–1.1 (SG). *Functional category:* Fixture, closure (cylindrical hinges for container, a box or a cupboard).

217 Bone spatula

AC IV, 162 = PAH II, 472, “una piccola spatola, forse per pulire le orecchie”; Falkener 1852, 82, n., “an ear-pick”. *Present location:* MANN *Reg. Im.* 22.7.1847. Probably SG, *Bronzi minuti*, 2772, “piccola spatula di osso forse per pulire orecchie onces quattro e due quinti.” *Dimensions:* L 9.7 (SG). *Functional category:* Instrument, medical/cosmetic.

August 31, PAH II, 473, “nel ricercare le terre”.

218 Bronze patera

AC IV, 162 = PAH II, 473, “una patera col manico dissaldato”; Falkener 1852, 82, n., “patera”. *Present location:* MANN *Reg. Im.* 4.10.1847. Not located. *Comments:* The detached handle points to the identification as a patera of category H. *Functional category:* Vessel, ablutions.

R15 TABLINUM

In this prestigious room distinguished by *opus sectile* floor²⁴ elements referring to central painting on wooden panels were found, as reported by Panofka: “un'altra grande stanza di lusso la quale sembra essere stata decorata alter volte da quadri pregevoli dipinti sul legno, a giudicare d'appresso lo stato attuale delle pareti, il numero dei chiodi e le cornice in legno che ivi furono scoperte”.²⁵ The loose finds from the tablinum are very difficult to pinpoint, as it seems to have been excavated not as a single unit, but together with other rooms; first with the adjoining part of the atrium, and then, the rear part in connection with the garden R18. Falkener attributes only the two terracotta statuettes (Cat. 219 and 221) and a coin (Cat. 224) to this room. These finds were made, according to the *PAH*, on March 31 and April 1, with both days revealing one female terracotta statuette and fragments of a stucco ceiling. These finds appeared in the middle of the preceding and succeeding working days in the atrium, and the distinction between the atrium and tablinum finds is thus not quite clear. The ceiling fragments (Cat. 223) from April 2 probably belong to the tablinum as well. After the excavation of the first parts of the garden, in the front area with the statues, the *PAH* expressly states that a coin (Cat. 224) and a marble statue of a Faun (Cat. 247) were found in the “left side of the tablinum” on April 28. On the following day, another group of finds, mostly statues, was found at the “back of the tablinum”. In Falkener's catalogue, however, all of the statues and the finds from April 28 have been listed together with the finds from the garden area. The other three entries, all of them for architectural fragments, were recorded by Falkener as deriving from the upper layer of the floor above the tablinum (lead tubes, Cat. 225; lion gutter, Cat. 226; antefix, Cat. 227).²⁶ Panofka states that a skeleton was found here.²⁷

March 31

219 Terracotta statuette (standing draped female) I.2.3

AC IV, 72–73 = *PAH II*, 461, “una statuetta avvolta in un panno giallo dorato: la medesima che doveva forse servire per ornamento, è mancante della testa, delle mani e de' piedi: la sua attuale altezza è di tre decimi di palmo”; Falkener 1852, 57, “two terra-cotta figures, 7 ½ ins. high, were found in the tablinum, the heads, hands, and feet of which were wanting”. *Present location*: MANN *Reg. Im.* 22.7.1847, *SG* noted at margin. *SG*, *Terrecotte*, 5267. *Inv. Fiorelli*, 21611, “statuetta di terracotta avvolta in un panno giallo dorato, la medesima che doveva forse servire di ornamento, è mancante della testa, delle mani e dei piedi. La sua attuale altezza è di 0.079”. *Functional category*: Architectural, ceiling decorations.

220 Fragments of gilded stucco mouldings s.n.

AC IV, 73 = *PAH II*, 461, “alcuni frammenti di cornicette dorate”; Raoul-Rochette 1852, 299. *Present location*: MANN *Reg. Im.* 22.7.1847, “Vari pezzi di cornici dorate. Affreschi: Suggellati in una cassa a graticola di ferro sopra per vederli, senza n.” Not located. *Comments*: Similar to Cat. 18, 26, 46, 220, 222, 223, see discussion for structural finds. *Functional category*: Architectural, ceiling decorations.

April 1

221 Terracotta statuette (standing draped female) I.2.2

AC IV, 73, “una statuetta come la testè descritta”; *PAH II*, 461, “una statuetta in tutto simile a quello del giorno precedente”; Falkener 1852 (see previous). *Present location*: MANN *Reg. Im.* 22.7.1847, *SG* noted at margin.

²⁴ *PAH II*, 461; Panofka 1847 a, 136; Pancaldi 1848, 7–8; Bechi 1852, 8; Falkener 1852, 55–58; Raoul-Rochette 1852, 299; Minervini 1854, 12; 1855, 54–55; Dwyer 1982, 37–38; *PPM IX*, 251–253, Tammisto – Kuivalainen 2008, 88–89.

²⁵ Panofka 1847 a, 136.

²⁶ For the mix-up of the finds from this room with ala R8 by Panofka 1847 b, 136, see R8.

²⁷ Panofka 1847 a, 36.

SG, Terracotte, 5268. Inv. Fiorelli, 21612, "statuetta in tutto simile a quella descritta di sopra". Functional category: Architectural, ceiling decorations.

222 Fragments of gilded stucco mouldings s.n.

AC IV, 73, "altri frammenti di cornicetta"; PAH II, 461, "altri frammenti di cornicette, come quelle de'giorni precedenti". Present location: MANN. Not located. Comments: Similar to Cat. 18, 26, 46, 220, 222, 223, see discussion for structural finds. Functional category: Architectural, ceiling decorations.

April 2

223 Fragments of gilded stucco mouldings s.n.

Not in AC; PAH II, 461, "frammenti di cornicette, in tutto simili quelle de'giorni precedenti". Present location: Not located. Comments: Similar to Cat. 18, 26, 46, 220, 222, 223, see discussion for structural finds. Functional category: Architectural, ceiling decorations.

April 28, PAH II, 463, "lato sinistro del tablino".

224 Bronze coin

AC IV, 73 = PAH II, 463, "una moneta di Claudio di modulo mezzano"; Falkener, 58, "coin of the emperor Claudius". Present location: MANN Reg. Im. 22.7.1847. Not located. Functional category: Instrument, economic.

March 29, "Ist floor over tablinum"

225 Two pieces of lead pipe

Falkener 1852, 70, "On 29th of March, and about ten feet from pavement, two pieces of lead pipe, for the supply of the fountain on the first floor, were found in the tablinum." Present location: Unknown. Comments: According to PAH, two pieces of lead were found 1st September. Functional category: Architectural, hydraulic.

April 14

226 Terracotta gutter with lion's head (see Fig. 1, p. 195)

*AC IV, 73, "un canale di terracotta fatto a testa di leone"; PAH II, 462, "un canale di terracotta a testa di leone"; Falkener 1852, 70, "portion of cornice-gutter, with lion's head, which had crowned the hypaethral walls over compluvium of atrium, were found in the same apartment"; Minervini 1854, 21, "una parte di gocciolatoio, con testa di leone" = 1855, 86; Von Rohden, 70; Dwyer 1982, 37, ii. Present location: MANN Reg. Im. 22.7.1847. SG, Terracotte, 5277, "frammento di una maschera leonina; alto cinque decimi e largo due decimi". Inv. Fiorelli, 20733, "frammento di una maschera leonina, alta 0.110 per 0.044". Dimensions: H 11, W 4.4. Functional category: Architectural, decoration of the *compluvium*.*

227 Terracotta antefix

*Falkener 1852, 70, "antefixa"; Minervini 1854, 21, "un'antefissa" = 1855, 86. Present location: Unknown. Not in PAH, not found in Reg. Im. Possibly SG, Terracotte, 5280, "Piccola antefissa frammentata. In essa vi è a basorilievo una maschera giovanile in mezzo agli arabeschi. Alta quattro decimi e larga quattro decimi e mezzo." Functional category: Architectural, decoration of the *compluvium*.*

R16 TRICLINIUM

The most prestigious room in the house for its size, with elaborate mythological paintings and an intricate mosaic floor, triclinium R16 produced only a very few finds, unearthed on May 18.²⁸ Among these is one of the most commented-upon pieces from the house, the fragments of a decorated silver-plated bed or bench (Cat. 228). In addition, both the *PAH* and Falkener report hinges of structural doors (Cat. 229–231), a dice (Cat. 232), and a terracotta cup (Cat. 233), whereas only the *PAH* associates a nail head (Cat. 234) with them.

May 18, *PAH* II, 465, “nel triclinio contiguo [ad ala dritta] si è rinvenuto”.

228 Wooden bed/bench with decorations in silver plate

AC IV, 74, “un mobile marcito con sopravi un cuscino (forse una lunga panca per sedere), poggiata sopra otto piedi rivestiti di patine di argento. Vi erano vicino due fasce dello stesso metallo a guisa di braccialetti”; *PAH* II 465, “si è rinvenuto marcito un mobile con cuscino superiormente (forse una lunga panca per sedere). La medesima era poggiata sopra otto piedi rivestiti di foglie di argento, ma molto sconservati. Appartenevano a questo mobile altre piccole fasce in forma di bracciali anche in argento”; Panofka 1847 b, “un pregevolissimo lettisternio con piè d’argento e cuscino bruciato”; Bechi 1852, 10 “nello scavare questo triclinio si rinvennero attorno di esso le tracce di un ricco sedile che lo circondava in tre lati a modo di divano. Questo sedile era poggiato sopra otto piedi di legno tornito rivestiti da laminette di argento con anima di ferro nel mezzo fissata nel pavimento”; Falkener, 66, “In this room was found a long bench (lectisternium), covered with silver plates, and resting on eight legs, but unfortunately, in bad preservation. It had been covered with cushions. Among the ornaments belonging to it were silver zones in the form of bracelets”; Minervini 1854, 19, “Fra gli oggetti preziosi veggonsi pur conservati i residui del nobile letto rinvenuto nel triclinio. Si veggono alcuni pezzi dei bastoni di ferro con parte del legno, onde erano costituiti i piedi di quel mobile, con una porzione del rivestimento di argento. Altri ornamenti parimenti di argento di finissima lamina, quasi distrutti, sono il solo residuo di quella importante scoperta” = 1855, 81, “ed è dispiacevole che non ne fu tratto subito un disegno” Fiorelli 1875, 392, “vi stava il letto tricliniare co’ piedi di argento e gli avanzi delle culcitae con le impressioni di un tessuto variopinto”; Dwyer 1982, 38, i. *Present location*: MANN *Reg. Im.* 22.7.1847, *SG* noted at margin. *SG*, *Oggetti preziosi*, 424, “n. otto piedi di legno rivestiti di foglie di argento molto ruinato”; *SG*, *Oggetti preziosi*, 425 e 426 “due piccole fasce a forma di bracciali tutte frammentate”. *Inv. Fiorelli*, 25786, “dodici frammenti di ferro ossidati, cinti in parte da rivestimenti di sottile lamina argento frammentato; e questi sono tanto logori da potersi appena discernere, alcuni sono ancora ricoperti di lapillo”. Not located. *Functional category*: Furniture.

229–231 Three bronze pivot hinges

AC IV, 74, “tre arpioni”; *PAH* II, 465, “tre billici di porta, uno di essi privo di piastra”; Falkener 1852, 58, “It had double doors between it and the ala. One of the bronze hinge plates yet remains on the side of the exhedra; and three others were discovered loose, and sent to the Museum of Naples”. *Present location*: MANN *Reg. Im.* 22.7.1847. Not located. *Functional category*: Fixture, closure (structural door).

232 Bone dice

AC IV, 74 = *PAH* II, 465, “un dado bruciato”, Falkener 1852, 66, “dice”. *Present location*: MANN *Reg. Im.* 22.7.1847, *SG* noted at margin. *SG*, *Bronzi minuti*, 8329, “un dado di osso bruciato, della dimensione di quattro quinti di oncia”. *Dimensions*: 1.8 (*SG*). *Functional category*: Instrument, entertainment.

233 Terracotta cup

AC IV, 74 = *PAH* II, 465, “una tazzolina rotta”, Falkener 1852, 66, “terra cotta tazza”. *Present location*: MANN *Reg. Im.* 22.7.1847. Not located. *Functional category*: Vessel, culinary consumption.

²⁸ *PAH* II, 465; Panofka 1847a, 133–136; Avellino 1848, 10–13; Bechi 1852, 10; Falkener 1852, 58–66; Minervini 1854, 13–15; Breton 1855, 302; Dwyer 1982, 38; *PPM* IX, 254–280, Tammisto – Kuivalainen 2008, 89–99.

234 Bronze nail head

AC IV, 74 = *PAH* II, 465, “una testa circolare di chiodo”. *Present location*: MANN, *Reg. Im.* 22.7.1847, “una testa di chiodo circolare”. Not located. *Functional category*: Fixture.

R17 FAUCES

Room 17, called a fauces in most early publications, is a narrow corridor, decorated with wall-paintings, mostly taken up by stairs leading to the upper level at the rear of the house.²⁹ The only reported find, other than a lead pipe conduit installed in the stairs, is a human skeleton (Cat. 235). As reported by Panofka: “Uno scheletro giaceva ancora sui gradini”.³⁰

April 20**235** Human skeleton

Falkener 1852, 68, “It is remarkable that a skeleton was found here”; Panofka 1847a, 142; 1847b, 131; Breton 1855, 302; De Carolis *et al.* 1998, 94, cat. 191. *Functional category*: Organic.

R18 GARDEN

The small garden R18, with its mosaic fountain aedicula, round pool, and numerous marble statues, was the central attraction of the house for scholars and tourists alike.³¹ The first statue was unearthed already on April 24, but the excavation of the room started, according to the *PAH*, on April 28, at the rear side of the tablinum (‘lato sinistro del tablino’, ‘fondo del tablino’), and it was only on May 3 that this space was recognized as a garden. The finds from the garden area are associated with numerous lacunae and contradictions regarding their provenances, as a result of which no object, besides the marble statues, can be entirely securely placed there. Besides the statues and oscilla, Falkener (p. 78, and n.) provides a list of 12 items found “in the garden, or adjacent members of the house”. A further six items are described as objects deriving from the upper floor of the house, or “from the upper portion of adjoining house” (p. 71), totalling 18 objects in all. Falkener also uses many generic expressions here, “several hinges”, “portions of furniture”, and “fragments of locks”, that add an undefined quantity to these numbers.

In the *PAH*, these same finds appear over a long arch of time, together with other finds, many of which are not mentioned at all by Falkener, totalling an additional 25 items. Included in this number are a glass cup (Cat. 265), a terracotta cup (Cat. 266), a hook (Cat. 277), a bronze modius (Cat. 304), a horse bit (Cat. 306), and seven ornaments from a container (Cat. 308).

The first marble statues appeared on April 24, and included three works plausibly located at the back edge of the tablinum, or front side of the garden: the Pan and Faun group (Cat. 236), a herm (238), and a hare (Cat. 239); however, there is also a bronze fibula that appears in Falkener’s garden list (Cat. 243). Four bronze hinges and nails found on this day have been located here in the Catalogue, although their provenience is less clear (Cat. 242, 244–244). On the following excavation day, April 26, excavation in the upper layers brought forth the marble ibis statue (Cat. 288) and the first oscillum plate (Cat. 289), and some vases in Falkener’s garden list (Cat. 286–287, 290). On April 28, according to the *PAH*, “sul lato sinistro del tablino”, and together

²⁹ Panofka 1847a, 131; Panofka 1847b, 142; Avellino 1848, 33; Bechi 1852, 11; Falkener 1852, 67–68; Minervini 1854, 15–16; Breton 1855, 302; *PPM* IX, 281–285.

³⁰ Panofka 1847 a, 131.

³¹ *PAH* II, 463–466; Panofka 1847a, 133; Pancaldi 1848, 8–9; Falkener 1852, 71–78; Breton 1855, 306; Minervini 1855, 56; Dwyer 1982, 38–48; *PPM* IX, 289; Kuivalainen 2008.

with a coin that Falkener ascribed to the tablinum, a Pan *aposkopos* (Cat. 247) emerged. The provenience could be interpreted as the left-hand side just at edge of the tablinum and the garden. On the following day, 29 April, three statues, of a duck (Cat. 251), a herm (Cat. 252), and a deer (Cat. 253) came to light, according to the *PAH* “at back of tablinum”, together with three minor finds: a lock (Cat. 250) and two hinges (Cat. 248–249).

According to the *PAH*, on May 3 a statue group of a faun, herm, and kid (Cat. 254) was found “at the left side of the garden”, and on May 4 the cow and ibis (Cat. 255, 256) came to light “in the garden”. On May 12, thirteen objects and three statues were found, the latter together with the garden fountain: the silen inside of it and two herms at its sides. This would have been the day on which, according to Falkener’s report, the two herms, found earlier and reburied, were “found again” in presence of the “Accademici”.

According to the *PAH*, on April 30 three finds (Cat. 291–293) were made in the upper layers, in unspecified rooms, but were included in the sequence of finds from the garden and its immediate surroundings. Among them was a beam of bronze scales (Cat. 291) mentioned by Falkener (p. 71) as among the finds that “had also fallen from the upper part of this house”. Falkener’s list of the sparse finds also includes an unguent bottle found on 12 May (Cat. 264), a bronze bracelet (Cat. 305) and a bronze bleeding cup (Cat. 309) found according to the *PAH* “near the garden” on June 9, a bronze lamp “fallen through the upper stratum of *lapilli*” on June 15 (Cat. 319=III.1.3), and a strigil found on 16 August in the upper fauces R28 (cat 353). Panofka mentions the horse bit and some bronze vases as discovered from the rooms along the upper, East side of the garden: “nell’ottava stanza si rinvenne una briglia di cavallo con vasi di bronzo di varie forme”.³²

April 24

236 Marble statue (Pan and Faun) I.1.6

PAH II, 463, “un gruppo rappresentante Pane e Fauno, che gli cava forse una spina dal piede: la base su cui poggiano queste due figure è di un palmo e nove decimi”; Falkener 1852, 76, fig. “In front of the piscina is a small group, 20 ins. long, of a Faun endeavouring to extract a thorn from the foot of Pan”. *Present location*: Stolen. Pompeii, old inv. 2060. *Functional category*: Object of art /plastic figure.

237 Marble statue (Dolphin and Cupid) I.1.9

PAH II, 463, “un delfino al quale manca la coda, cavalcato da un amorino, privo del braccio sinistro, poggiate su di un polipo: la sua intera altezza compresovi la base, la cui figura rappresenta un parallelepipedo, è di pal. 1 e tre decimi”; Falkener 1852, 77–78, “on each side of which [piscina] are Cupids riding dolphins”. *Present location*: Pompeii, inv. 20373. *Functional category*: Object of art /plastic figure.

238 Marble statue (bifrontal herm) I.1.2

PAH II, 463, “un’erma bicipite di un Bacco indiano e di un’Arianna: la sua altezza esclusane quella del pilastro, sul quale è poggiata, è di quattro quinti di pal.”; Falkener 1852, 74, “in front of garden are two other hermal statues of the same height, and each representing the Indian Bacchus and Ariadne”. *Present location*: Pompeii, inv. 20627. *Functional category*: Object of art/plastic figure.

239–241 Three marble statues (hares) I.1.11, I.1.12, I.1.13

PAH, II, 463, “un lepre accosciato, che mangia dell’uva; lo stesso è privo delle orecchie: la lunghezza della sua base è di un palmo”; Falkener 1852, 77, “around the piscina are other fanciful devices serving as ornaments, as panther eating grapes”. *Present location*: Pompeii, inv. 20369. *Functional category*: Object of art/plastic figure.

242 Bronze strap hinge

PAH II, 463, “una scibba a meccione”, Falkener 1852, 78, n., “several hinges”. *Present location*: MANN *Reg. Im.* 22.7.1847. Not located. *Functional category*: Fixture, closure (door).

³² Panofka 1847 a, 132.

243 Bronze fibula

PAH II, 463, “una fibietta”; Falkener 1852, 78, “small brooch”; Minervini 1854, 20, “(due) fibule” = 1855, 82. *Present location*: MANN *Reg. Im.* 22.7.1847. Not located. *Functional category*: Personal ornament.

244 Bronze strap hinge

PAH II, 463, “altra [scibba a meccione] per metà per lo stante”, Falkener 1852, 78, n., “several hinges”. *Present location*: MANN *Reg. Im.* 22.7.1847. Not located. *Functional category*: Fixture, closure (door).

245–246 Two bronze nails

PAH II, 463, “due piccoli chiodi con testa larga”. *Present location*: MANN *Reg. Im.* 22.7.1847. Not located. *Functional category*: Fixture.

April 28, *PAH* II, 463, “nello stesso locale”.

247 Marble statue (Satyre aposkopos) I.1.7

PAH II, 463, “una statuetta di altezza pal. 3 diunita alla base rappresentante Pane giovine, che ha una mano nella testa, e con l’altro sostiene il pedo, mancano le dita della mano destra e del piede sinistro”; Falkener 1852, fig. 76, “On the left of the piscina are two statues, each about 2 ft. 9 ins. high, the further of which represents a Faun with two short horns, but no tail walking lightly along, and holding perhaps a pedum in his left hand, and shielding his face from the sun with his right.” *Present location*: Pompeii inv. 20391. *Functional category*: Object of art/plastic figure.

April 29, “in fondo del tablino”.

248–249 Two bronze strap hinges

PAH II, 463, “due scibbe frammentate”, Falkener 1852, 78, n., “several hinges”. *Present location*: MANN *Reg. Im.* 22.7.1847, “due scibbe frammentate di bronzo”. Not located. *Functional category*: Fixture, closure (door).

250 Bronze lock plate

PAH II, 463, “una mascatura col suo lucchetto”, Falkener 1852, 78, n., “fragments of locks”. *Present location*: MANN *Reg. Im.* 22.7.1847, “una serratura col corrispondente lucchetto”. Not located. *Functional category*: Fixture, closure.

251 Marble statue (duck) I.1.16

PAH II, 463, “un’anitra di lunghezza pal. 1 1/2 e di altezza con la base pal. 1 priva di piedi”; Falkener 1852, 78, “goose on the left”. *Present location*: Pompeii inv. 20377. *Functional category*: Object of art/plastic figure.

252 Marble statue (Bacchic double herm) I.1.4

PAH II, 463, “Un’erma bicipite rappresentante Bacco indiano ed un’Arianna”; Falkener 1852, 74, “in front of garden are two other hermal statues of the same height, and each representing the Indian Bacchus and Ariadne”. *Present location*: Pompeii, inv. 20628. *Functional category*: Object of art/plastic figure.

253 Marble statue (deer) I.1.14

PAH II, 463–464, “Una cerva lunghezza pal. 1/2, e di altezza con la base 3/5 di pal. Priva delle corna”; Falkener 1852, 78, “hind”. *Present location*: Pompeii, inv. 20466. *Functional category*: Object of art/plastic figure.

May 3, “nel lato sinistro del giardino”.

254 Marble statue (Satyr herm with goat and kid) I.1.8

AC IV, 74, “Una statuetta mancante di mezzo braccio diritto, alta palmi 3 1/3, la quale raffigura un termine con un cestino al braccio sinistro, entro di cui è un capretto: al di sotto vedesi la madre con le zampe in alto poggiate sulla parte inferiore della statuetta medesima” = *PAH* II, 464; Falkener 1852, 77, fig., “The other hermal statue of a shepherd with a Pandean pipe, holding a kid in his left arm, while the dam is jumping up a

this side endeavouring to lick its offspring”. *Present location*: Pompeii, inv. 20393. *Functional category*: Object of art/plastic figure.

May 4, “nel giardino della suindicata casa”.

255 Marble statue (cow) I.1.15

AC IV, 74 = *PAH II*, 464, “un torello”; Falkener 1852, 78, “a cow”. *Present location*: Pompeii, inv. 20467. *Functional category*: Object of art/plastic figure.

256 Marble statue (ibis) I.1.17

AC IV, 74, “un uccello”; *PAH II*, 464, “ibis”; Falkener 1852, 78, “bird”. *Present location*: Pompeii, inv. 20376. *Functional category*: Object of art/plastic figure.

May 12, On this day, the discovery of the mosaic fountain in the garden was reported, at the end of the list, and consequently the earlier finds from this day may be interpreted as coming from the garden, or nearby rooms. Two of the finds appear in Falkener’s list, but there are many that he does not list. A suspicion arouses that, on this day, in the presence of the ‘Accademici’, the last parts of the cubiculum R7 might also have been excavated, for there are some similarities between these objects and those mentioned by Falkener for R7, which are otherwise completely absent from the *PAH*. Thus, the glass bottle, cup, and fragmentary terracotta vessel might be identified with Cat. 90–91 from R7. In particular, the unusual description of a broken terracotta cup (Cat. 266) with the term ‘argilla’ instead of terracotta could be an indication in this direction. Alternatively, the glass bottle may be the one mentioned by Falkener (Cat. 71) among the finds from the upper stories around the garden.

257 Bronze ‘casseruola’

AC IV, 74, “una casseruola col manico, rotta nel fondo”; *PAH II*, 464, “una cazzaruola col suo manico, la medesima è rotta nel fondo”; Falkener 1852, 78, “saucepan”. *Present location*: MANN *Reg. Im.* 22.7.1847, “patera col suo manico”, *SG* noted at margin. *SG*, *Bronzi minuti*, 2677, “Patera col suo manico. Diametro once sette e due quinti, con tutto il manico palmo uno e un quinto.” Not located. *Dimensions*: D rim 16.3; L with handle 31.7 (*SG*). *Functional category*: Vessel, pouring (culinary). Most probably this is a large example of Tassinari’s casserole type G, as it is broken at the base, but the handle is still attached.

258 Bronze lamp III.1.4

AC IV, 74, “una lucerna ad un sol lume con un manico”; *PAH II*, 464, “una lucerna ad un sol lume”; Falkener 1852, 78, “lamp”; Dwyer 1982, 52, i, fig. 56. *Present location*: MANN *Reg. Im.* 22.7.1847, “lucerna ad un sol lume e col suo manico”, *SG* noted at margin. *SG*, *Bronzi minuti*, 8324, “una lucerna ad un sol lume col suo manico in cui vi è una testa di uccello crestata. Lungo col manico once cinque e mezzo”. *Inv. Fiorelli*, 72295. *Comments*: Dwyer locates this lamp in the same place as the one found in R34, but according to all sources that one was decorated with the head of a goose, not cock (Cat. 427). The connection of lamps with the same cock protome as this piece comes from the *Registro Immissioni*, in which the *SG* number 8324 is annotated. *Functional category*: Instrument, lighting.

259 Iron cramp

AC IV, 74, “un gangheretto”; *PAH II*, 464, “una grappa con ferro ossidato”. *Present location*: MANN *Reg. Im.* 22.7.1847. Not located. *Functional category*: Fixture.

260–261 Two bronze pivot hinges

AC IV, 74, “due arpioni”; *PAH II*, 464, “due billici di porta muniti delle loro piastre”; Falkener 1852, 78, n., “several hinges”. *Present location*: MANN *Reg. Im.* 22.7.1847. Not located. *Functional category*: Fixture, closure (structural door).

262 Bronze lock plate

AC IV, 74, “un pezzo di serratura”; PAH II, 464, “uno scudo di serratura”; Falkener 1852, 78, “fragments of locks”. *Present location*: MANN Reg. Im. 22.7.1847. Not located. *Functional category*: Fixture, closure.

263 A group of three bronze fittings

AC IV, 74 = PAH, 464, “tre pezzi per guarnizione di mobili”; Falkener 1852, 78, “portions of furniture”. *Present location*: MANN Reg. Im. 22.7.1847. Not located. *Functional category*: Fixture, furniture.

264 Glass unguent bottle

AC IV, 74, “una boccetta a mo’ di palla col manico”; PAH II, 464, “una boccetta a palla col suo manico”, Falkener 1852, 71, “a glass vase”. *Present location*: MANN Reg. Im. 22.7.1847, SG 2805 noted at margin. Probably SG, *Vetri antichi*, 2804, “boccetta a palla col suo manico. Alta poco meno di mezzo palmo”. *Inv. Fiorelli*, 12037, “Piccola bottiglia a palla con manico striato, collo stretto e labbro sporto in fuori. Alt. mm. 120, diam. nella pancia mm 90.” *Dimensions*: H 12; D max 9 (*Inv. Fiorelli*). *Comments*: May be identical with Cat. 90, “glass vessels” from R7, in Falkener. *Functional category*: Vessel, medical/cosmetic.

265 Glass cup

AC IV, 74 = PAH II, 464, “una coppa rotta nella pancia”. *Present location*: MANN Reg. Im. 22.7.1847, “coppa rotta nella pancia”. *Functional category*: Vessel, culinary consumption.

266 Terracotta cup

AC IV, 74, “Argilla. Una tazza rotta”; PAH II, 464, “una tazza rotta in tre parti”. *Present location*: MANN Reg. Im. 22.7.1847, “tazza di argilla rotta in tre parti”, SG, *Terrecotte*, 5249 (erroneous), noted at margin. *Comments*: May be identical with Falkener’s “some fragments of terra-cotta” from R7. *Functional category*: Vessel, culinary consumption.

267 Bone fitting

AC IV, 74, “un pezzo da guarnizione”; PAH II, 464, “un pezzo per guarnizione”, Falkener 1852, 78, “portions of furniture”. *Present location*: MANN Reg. Im. 22.7.1847, SG noted at margin. SG, *Bronzi minuti*, 8325, “un pezzo di osso per guarnizione. E’ internamente forato, lunga circa once due”. *Inv. Fiorelli*, 78392, “altro simile piccolo pomo al precedente [guarnizione di mobile, con piroletto alla sommità]. Alt. mm 40.” *Dimensions*: H 4.0 (*Inv. Fiorelli*); L 4.4 (SG). *Functional category*: Fixture, furniture. A furniture fitting with an onion-shaped top.

268 Marble statue (Silenus) I.1.1

AC IV, 74, “nel picciolo giardino alle spalle del giardino, summontovato si scoperto una fontana a mosaico e conchiglie, in mezzo alla quale è una statuetta di marmo rappresentante Sileno alta palmi 2 1/3”; PAH II, 464, “una statuetta in marmo rappresentante un Sileno, la sua altezza è di circa pal. 2 5 /10”; Falkener 1852, 74, “In the center is a marble statue of Marsyas, 2 ft. 7 ins. high, holding a skin under his left arm, from which a jet of water flows down...” *Present location*: Pompeii inv. 20392. *Functional category*: Object of art/plastic figure.

269 Marble statue (bifrontal herm) I.1.3

AC IV, 74, “Allato alla fontana su due pilastrini sono due erme bicipiti”; PAH II, 464 “al lato alla fontana sopra due pilastrini vi sono due erme bicipiti”; Falkener 1852, 74, “On each side is a bicipital hermal statue, 4 ft. high including base, the heads of which exhibit a bearded Bacchus and Ariadne, on the left”. *Present location*: Pompeii, inv. 20398/20404. *Functional category*: Object of art/plastic figure.

270 Marble statue (bifrontal herm) I.1.5

See above, Cat. 269. Falkener 1852, 74, “...and a male and female Faun on the right both distinguished by short horns”. *Present location*: Pompeii, inv. 20397 (head missing). *Functional category*: Object of art/plastic figure.

May 22, PAH lists these under the finds of ala R9–10, excavated this day.

271 Marble statue (Dolphin and Cupid) I.1.10

PAH II, 465, “un amorino che cavalca un delfino poggianti su d’un polipo, simile all’altro descritto nel giorno 24 aprile p.s.”; Falkener 1852, 77–78. *Present location*: Pompeii, inv. 20374. *Functional category*: Object of art/plastic figure.

272 Terracotta statuette of Minerva

PAH II, 465, “una statuetta di Pallade in due pezzi, mancante delle braccia e de’ piedi”; Falkener 1852, 78, “statue of Minerva”; von Rohden, 70; Dwyer 1982, 32, iii. *Present location*: MANN. *SG*, *Terracotte*, 5279, “mezzo palmo, once tre”. *Inv. Fiorelli*, 20634, “statuetta di Pallade in due pezzi mancante delle braccia e de’ piedi, ed una piccola ara. Il frammento della Pallade è di 0,132 per 0,066, l’ara e’ di 0,066.” Dimension: H (statuette) 132.0, l. 6.6; H (altar) 6,6 (*Inv. Fiorelli*). *Preservation*: Two pieces, arms and head missing. *Discussion*: The *PAH* lists these under the finds from ala 9–10, while Falkener locates both the statue and the following terracotta altar together in the garden. *Functional category*: Object of art/plastic figure/cult.

273 Terracotta altar

PAH II, 465, “una piccola ara”; Falkener 1852, 78, “a small terra cotta altar”; Dwyer 1982, 32, iv. *Present location*: MANN. *SG*, *Terracotte*, 5279. *Inv. Fiorelli*, 20634, not located. *Dimensions*: H 66 (*inv. Fiorelli*). See cat. 272 above. *Discussion*: See above. The *PAH* lists these under the finds of ala 9–10, while Falkener locates them in the garden, see above. *Functional category*: Furniture, cult.

May 25**274** Bronze amphora II.1.1

AC IV, 74, “Un’olla alta un palmo, con manichi distaccati”; *PAH* II, 466, “una olla a due manici distaccati, alta 1 pal.”; Falkener 1852, 78, n., “(two) olearia”; Minervini 1854, 20, pl. IV, 15, “per la sua conservazione, abbiamo creduto opportuno di pubblicare uno de’ vasi con ornati manici, che può vedersi riportato nella tav. IV, figura 15”. *Present location*: MANN *Reg. Im.* 22.7.1847, “un’olla a tre (sic) manici distaccati dell’altezza di un palmo”. *SG*, *Bronzi minuti*, 8439, “Olla di bronzo con due manici, ne quali si sono ornamenti con intarsiature di argento e teste giovanili coronati di edera, altezza palmo uno”. *Inv. Fiorelli*, 69470: “altro vaso in tutto simile al precedente. L’orlo è intatto. Antico Invent., N° 8439”. *Dimensions*: According to the detailed description in the *SG*, we can securely identify this vase with the one illustrated in the volume of Niccolini brothers. *Comments*: Cf. Cat. 303. *Functional category*: Vessel, pouring (water or wine, banquet service).

275 Bronze pivot hinge

PAH II, 466, “un bilico colla corrispondente piastrina”, Falkener 1852, 78, n., “several hinges”. *Present location*: MANN *Reg. Im.* 22.7.1847. Not located. *Functional category*: Fixture, closure (structural door).

276 Bronze strap hinge

PAH II, 466, “una sciba per lo stante”, Falkener 1852, 78, n., “several hinges”. *Present location*: MANN *Reg. Im.* 22/9/1847. Not located. *Functional category*: Fixture, closure (door).

277 Bronze hook

PAH II, 466, “un doppio uncino”. *Present location*: MANN *Reg. Im.* 22/9/1947, “un doppio manico”. Not located. *Comments*: The wording of the *PAH* seems to refer to a fishing hook with points on two sides; however, the Registro Immissioni at the MANN mentions that it would rather have been a double handle. *Functional category*: Instrument, fixture or vessel, unknown function.

278 Marble mask (Faun) I.1.20

AC IV, 74, “Una testa virile grande quanto il vero, con capelli corti e mustacchi, orecchie faunine, e con la bocca aperta, certo per getto di acqua”; *PAH* II, 466, “una testa virile della grandezza del vero con corti capelli, con mustacchi, con orecchie faunine e colla bocca aperta, certamente per getto d’acqua”; Falkener 1852, 73, “A marble mask of the head of a Faun, with short hair, mustaches, long ears, and open mouth, probably formed one of these suspended decorations, if, indeed, it did not serve as the ornament of a fountain on the upper floor”. *Present location*: MANN *Reg. Im.* 22.7.1847. *SG*, *Marmi*, 456/1629. *Inv. Fiorelli*, 6610. *Discussion*: The

MANN collections of small marble sculptures has been published, and the only item corresponding to the description is a Mask of a Faun, 254–255, cat. E 82, with unknown provenience in Pompeii (inv. 6610, *SG* 656). Carrella et. al, 2008. The *SG* Nr. proposed by Dwyer for the faun from the House of Marcus Lucretius is 1629. In the *SG*, this number corresponds to a relief head listed in between the ML oscilla as ‘la testa di un faunetto con bocca aperta poggjata contro un masso a forma di pilastro’. Even if the collocation in the list is plausible, the description is quite different from the earlier ones, a faunetto rather a juvenile faun, and the posterior pilaster is not mentioned in any earlier source. The *Registro Immissioni*, instead, cites for the Faun of M. Lucretius quite another number, *SG* 456, but this is certainly erroneous, as the number refers to quite a different object in the *SG* catalogue. At this point, it seems probable that the number 456 of the *Reg. Im.* could have been mistaken for 656, and is identical to the published piece, with a description much more similar to the *PAH* entry: “maschera di satiro con corna e barba folta, occhi e bocca forata. Alta palmo uno ed oncia una, per once sette”. Although doubt remains, it is probable that MANN inv. 6610 is the specimen found in the House of Marcus Lucretius. *Functional category*: Object of art/plastic figure.

279–282 Globular terracotta money-box with three coins

AC IV, 74 = *PAH* II, 466, “un salva-monete di forma rotonda, con dentro tre monete, una di Vespasiano gran bronzo, l'altra di Galba medio bronzo, e la terza di Domiziano anche di medio bronzo”; Falkener 1852, 78, “circular money box containing a large bronze medal of Vespasian, a smaller one of Galba, and another of Domitian”; Minervini 1854, 21, “salvadanai ... uno di forma rotonda, entro del quale si conservavano ancora tre monete di bronzo di Vespasiano, di Galba, e di Domiziano” = 1855, 85. *Present location*: MANN *Reg. Im.* 22.7.1847. *SG*, *Terrecotte*, 5253. *Inv. Fiorelli*, 24538, “vaso detto salvamonete di forma rotonda, con tre monete dentro, una di Vespasiano, gran bronzo. Alto 0.132”. Not located. *Functional category*: Instrument, economic.

283 Marble oscillum (rectangular pinax) I.1.25

AC IV, 74 = *PAH* II, 466, “due frammenti di scudo di forma quadrata per l'intercolunnio”; Falkener 1852, 73. *Present location*: MANN *Reg. Im.* 22.7.1847. *SG* 1630. At present *s.n.* *Functional category*: Object of art/plastic figure.

May 27

284 Terracotta lamp

AC IV, 75 = *PAH* II, 466, “lucerna in terracotta”; Falkener 1852, 78, n., “lamp”: *Present location*: MANN *Reg. Im.* 22.7.1847. Not located. *Functional category*: Instrument, lighting.

285 Stucco relief head

Falkener 1852, 74, “near these [*i.e. hermal statues*] was found a head of Typhon, formed of stucco and covered with porcelain”. *Present location*: Unknown. Not located. *Functional category*: Object of art/plastic figure.

Upper layers/ first floor

April 26, “dall'alto delle terre”.

286 Oval bronze basin

AC IV, 73 = *PAH* II, 463, “una piccola conca di forma ovale, con due piccoli manici distaccati”; Falkener 1852, 78, “small oval basin with two handles”. *Present location*: Unknown. Not located. *Comments*: The oval form with two attached handles should correspond to Tassinari cat. O2000. *Functional category*: Basin, ablutions (hygienic).

287 Bronze handle

AC IV, 73 = PAH II, 463, “un piccolo manico di mobile”, Falkener 1852, 78, n., “portions of furniture”. *Present location*: Unknown. Not located. *Functional category*: Fixture, furniture.

288 Marble statue (ibis) I.1.18

AC IV, 73 = PAH II, 463, “un uccello aquatico, forse un ibi, in più pezzi”; Falkener 1852, 78, “bird”. *Present location*: Pompeii, inv. 20378. *Functional category*: Object of art/plastic figure.

289 Marble oscillum (disc) I.1.21

AC IV, 73 = PAH II, 463, “un disco per intercolumnio, che da un lato ritrae il sacrificio di un vitello, a dall’altro una figura virile barbata, che offre una cesta ripiena innanzi ad un’ara, su cui è acceso il fuoco, il suo diametro è di pal. 1 1/5.” *Present location*: MANN. *SG, Marmi*, 1627. *Inv. Fiorelli*, 6648. *Functional category*: Object of art/plastic figure.

290 Terracotta mug

AC IV, 73 = PAH II, 463, “un pignattino ad un manico rotto nella pancia”; could be: Falkener 1852, 78, “small jar”. *Present location*: MANN *Reg. Im.* 22.7.1847. Not located. *Functional category*: Vessel, culinary consumption. The vessel may be a thin-walled one-handed mug.

April 30, Falkener provides a list (p. 71) of a group of objects fallen “from the upper portion of adjoining house”. Of these, the *PAH* (II, 463) mentions the balance (Cat. 291) as found on April 30 in the upper layers (“dall’alto delle terre”), together with two other items not mentioned by Falkener. Probably from the 1st floor over the rear part of the house.

291 Beam of bronze scales

AC IV, 74 = PAH II, 464, “un’asta di bilancia”; Falkener 1852, 71, “beam of balance”. *Present location*: MANN *Reg. Im.* 22.7.1847. Not located. *Functional category*: Instrument, weighing.

292 Bronze latch

PAH II, 464, “una zeccola”. *Present location*: MANN *Reg. Im.* 22.7.1847, “una così detta zeccola”. Not located. *Comments*: This unusual word in the 19th century Neapolitan dialect meant a closing element for a window or door, a latch or hasp. Missing both in Falkener and the *AC*. *Functional category*: Fixture, closure.

293 Bronze nail

AC IV, 74 = PAH II, 464, “una testa di chiodo”. *Present location*: MANN *Reg. Im.* 22.7.1847. Not located. *Functional category*: Fixture.

May 19, *PAH II, 465*, “nel braccio sinistro della piccola fontana della nota casa delle Sonatrici, all’altezza di circa pal. 7 si è rinvenuto”. To the left of the fountain, in the upper layers.

294 Marble oscillum (pelta) I.1.22

AC IV, 74 “Nel lato sinistro della fontana. Uno scudo da intercolumnio”; *PAH II, 465*, “uno scudo per intercolumnio a forma di pelta lunata”. *Present location*: MANN *Reg. Imm.* 22.7.1847, *SG* noted at margin. *SG, Marmi*, 1628. *Inv. Fiorelli*, 6663. *Functional category*: Object of art/plastic figure.

June 8 *PAH II, 466*, “...col rinvenirsi li seguenti oggetti caduti dall’alto”. In the upper layers.

295 Bronze lock

AC IV, 75 = PAH II, 466, “un lucchetto”, Falkener 1852, 78, n., “several locks”. *Present location*: MANN *Reg. Im.* 22.7.1847. Not located. *Functional category*: Fixture, closure.

296 Bronze lock

AC IV, 75, “un altro più picciolo”; *PAH II, 466*, “altro più piccolo”, Falkener 1852, 78, n., “several locks”. *Present location*: MANN *Reg. Im.* 22.7.1847. Not located. *Functional category*: Fixture, closure.

297 Bronze lock plate

PAH II, 466, “forse una mappa di cassa”, Falkener 1852, 78, n., “several locks”. *Present location*: MANN *Reg. Im.* 22.7.1847. Not located. *Functional category*: Fixture, closure.

297bis Bronze pivot hinge base

PAH II, 466, “una piastra di bilico colla sua impiombatura”. *Present location*: *Reg. Im.* 22.7.1847. Not located. *Functional category*: Fixture, closure (structural door).

298 Bronze furniture fitting

AC IV, 75, “un pezzo di guarnizione di mobile”; *PAH* II, 466, “una guarnizione di mobile”, Falkener 1852, 78, n., “portions of furniture”. *Present location*: MANN *Reg. Im.* 22.7.1847. Not located. *Functional category*: Fixture, furniture.

299 Bronze coin

AC IV, 75 = *PAH* II, 466, “una moneta di modulo piccolo”. *Present location*: MANN *Reg. Im.* 22.7.1847. Not located. *Functional category*: Instrument, economic.

300–301 Two bronze nails

PAH II, 466, “due chiodi, uno de’ quali con testa larga”. *Present location*: MANN *Reg. Im.* 22.7.1847. Not located. *Functional category*: Fixture.

302 Marble oscillum (pelta) I.1.25

AC IV, 75 = *PAH* II, 466, “uno scudo per intercolumnio a forma di pelta lunata in tre frammenti”. *Present location*: MANN *Reg. Im.* 22.7.1847. *SG*, *Marmi*, 1632. Now *s.n.* *Functional category*: Object of art/plastic figure.

June 9, *PAH* II, 466: “in vicinanza del giardino si sono rinvenuti li seguenti oggetti”.

303 Bronze amphora II.1.2

AC IV, 75, “un’olla a due manichi staccati, alta un palmo”; *PAH* II, 466, “un’olla a due manichi distaccati dell’altezza di 1 pal.”; Falkener 1852, 78, n., “two olearia with two handles each”. *Present location*: MANN *Reg. Im.* 22/9/1847. *SG*, *Bronzi minuti*, 8440, “altra olla a due manichi, compagna della precedente, della altezza di un palmo”. *Inv. Fiorelli*, 69469: “Vaso ad olla con collo corto ed orlo ornato di ovoli. Ha due manichi co diversi ornamenti che si attaccano alla pancia con maschere bacchiche giovanili. Altezza mill. 274, Diametro maggiore mill. 260. Il fondo è tornito. Manca di una porzione dell’orlo”. *Discussion*: Falkener lists it as coming from the garden, or adjacent sections of the house. Another olla found on May 25th. Cf. *Cat.* 274. *Functional category*: Vessel, pouring (wine or water, banquet service).

304 Bronze vase of modius shape

AC IV, 75 = *PAH* II, 466, “un modio alto circa 1 pal. largo pal. 1 1/10 con due manichi distaccati”; Minervini 1854, 20=1855, 82, “Merita poi di essere particolarmente rammentato un modio alto circa un palmo e largo p. 1 ½ rinvenuto coi manichi distaccati”; Dwyer 1982, 48, xxv. *Present location*: MANN *Reg. Im.* 22.7.1847. *SG*, *Bronzi minuti*, 8441, “un modio con due manichi, alto circa un palmo, largo palmo uno ed un decimo”. Not located. Dimension: H 26.5; D 29.2 (*PAH*, *SG*). *Comments*: As Minervini notes that the vessel is worthy of particular attention, it may have been a rare barrel-shaped modius measure. The height and diameter of the vessel, both near to one Roman foot (29 cm), might confirm this identification. If the vessel was not a true modius measure, the denomination might refer to a large cylindrical vase with vertical walls and a flat base. This form most closely corresponds with Category W 1000 of Tassinari (Secchie) I 106–107, II 295–296. The type is very rare, and only two examples exist in the Pompeii Storerooms of similar, large dimensions (their heights 24.7 and 25.3 cm). The form is provided with bronze loops attached at the rim, for the fixture of an arched single handle. Its manufacture is modest, from thin metal, neither cast nor decorated, and it can be classified as a utilitarian vessel for the transport of water. *Functional category*: Vessel for measuring grain and flour (*modius*), or pouring water?

305 Bronze bracelet III.4.2

AC IV, 75 = PAH II, 466–467, “un braccialetto avente nel di sopra una laminetta di argento, figurante la testa del Sole radiata di faccia”; Falkener 1852, 71, “bronze bracelet, with a plate of silver representing the sun radiated”; Minervini 1854, 19, tav. IV,4, “un braccialetto di bronzo, coll’ornamento di disco di argento, ov’è figurata la testa di Sole radiata” = 1855, 81; Ceci 1858, IX, 56, “braccialetto che presenta nella parte anteriore un ornamento circolare in cui è effigiata in rilievo una testa di donna diadematata. Pompei”; Dwyer 1982, 48, xxiv. *Present location*: MANN *Reg. Im.* 22.7.1847. *SG, Bronzi minuti*, 8332, “un braccialetto avente di sopra una laminetta di argento figurante la testa del Sole radiata di faccia. Diametro maggiore onces quattro”. *Inv. Fiorelli*, 77180, “altro di cui estremi si attorcigliano ed avendo un disco, sul quale evvi una laminetta circolare in argento, rappresentante una testa radiata. Diam. mill. 82”. *Comments*: The bracelet appears illustrated by Minervini 1854, tav. IV. Falkener lists it as coming from the upper parts of the adjacent house. *Functional category*: Personal adornment.

306 Bronze horse bit

AC IV, 75 = PAH II, 467, “briglia di cavallo”; Panofka 1847 a, 132, “una briglia di cavallo”; Pancaldi 1848, 12; Minervini 1854, 20 = 1855, 82 “una briglia di cavallo”. *Present location*: MANN *Reg. Im.* 22.7.1847. *SG, Bronzi minuti*, 8333, “una briglia di cavallo con lapillo aderente, lunga poco più di un palmo”. Not located. *Dimensions*: Ca 26.5 (SG). *Functional category*: Fixture, transport.

307 Bronze bell

AC IV, 75 = PAH II, 467, “un campanello”; Falkener 1852, 78, n., “small bell”; Minervini 1854, 20, “un campanello (*tintinnabulum*)” = 1855, 82. *Present location*: MANN *Reg. Im.* 22.7.1847. Not located. *Functional category*: Instrument, sound. This might be a decoration and apotropaic element of the horse harness, or the doorway of the house.

308 Seven bronze discs

AC IV, 75 = PAH II, 467, “sette ornamenti di cassa”. *Present location*: MANN *Reg. Im.* 22.7.1847. *SG, Bronzi minuti*, 8334–8340, “Sette ornamenti forse per cassa, cioè il primo un disco con tracce di argentatura di due onces e tre quarti di diametro; altro con due appendici della stessa lunghezza. Tre dischi uniti fra loro, altri simili frammentati, e tre dischi con asta prominente, ad un solo del quale è unito un’anello cui trovasi infissato un oggetto a forma di cuore”. *Functional category*: Fixture (decorative studs for a box-like container?). Silvered disc of diam. 6.5, another disc with two appendixes of equal length. Three united discs, and fragments of others, three discs with a protruding beam. A ring with a heart-shaped applique is attached to one of the discs.

309 Bleeding cup III.2.8

AC IV, 75 = PAH II, 467, “un vasetto di forma ovale dell’altezza di 5/10 di pal. privo di manici, ed avente nella parte inferiore un anello dissaldato”; Falkener 1852, 71, “bronze cup”. *Present location*: MANN *Reg. Im.* 22.7.1847, “vasetto di forma ovale senza manici”. *Inv. Fiorelli*, 77988. *Comments*: Bliquez 1994 putatively attributed this object to the House of Marcus Lucretius, and this has been confirmed by the present research. *Functional category*: Instrument, medical.

310–313 Four bronze fittings for furniture

PAH II, 467, “Quattro frammenti forse di guarnizione di mobile”; Falkener 1852, 78, n., “portions of furniture”. *Present location*: MANN *Reg. Im.* 22.7.1847. Not located. *Functional category*: Fixture, furniture.

314–315 Two iron locks

AC IV, 75, “due pezzi di serratura”; PAH II, 467, “due mappe di serratura”, Falkener 1852, 78, n., “fragments of locks”. *Present location*: MANN *Reg. Im.* 22.7.1847. Not located. *Functional category*: Fixture, closure.

316–317 Two iron bars

AC IV, 75 = PAH II, 467, “due staffe”. *Present location*: MANN *Reg. Im.* 22.7.1847. *SG, Bronzi minuti*, 8341–8342, “due staffe di ferro ossidate, lunghe unite un palmo e oncia una”. Not located. *Dimensions*: L together 28.7 (SG). *Functional category*: Fixture, closure or transport. Possibly elements of the chariot.

318 A group of three iron bolts

AC IV, 75 = PAH II, 467, “tre perni”. *Present location*: MANN Reg. Im. 22.7.1847. Not located. *Comments*: Possibly elements of the chariot. *Functional category*: Fixtures, transport.

June 15, PAH II, 467, “dalla sommità delle terre, ed all’altezza di circa palmi 8, è caduto fra lo strato di lapillo”, Falkener 1852, 71, “fallen from the upper part of this house”. In the upper layers.

319 Bronze lamp III.1.3

PAH II, 467, “una lucerna di bronzo ad un lume priva di turacciolo, e con piccola porzione di catena”; Falkener 1852, 71, “bronze lamp”. *Present location*: MANN Reg. Im. 22.7.1847. SG, *Bronzi minuti*, 8343, “Una lucerna di bronzo ad un sol lume priva di turacciolo e con piccola porzione di catena. Lunga onces quattro e mezzo”. Inv. Fiorelli, 722118, “altra [lucerna] con maglia verde, il becco e piccolo anelletto, alta mm. 22, diam. mm 52, l mm 105”. *Functional category*: Instrument, lighting. Without date, probably from garden R18.

320–321 Two pelta shaped oscilla I.1.22, I.1.23

Falkener 1852, 73, “two resembling the Amazonian pelta”; Minervini 1854, 21=1855, 86: “alcuni scudi a guisa di pelta lunata”. *Present location*: MANN 6669. *Functional category*: Object of art/plastic figure.

August 16**R19–R20**

According to Falkener 1852 (72, n.), only eleven items were found in these rooms (Cat. 332, 324–326, 330–333, 335–336, 340).

September 6**322** Bronze patera

AC IV, 162, “una patera del diametro 6/10, senza manico”; PAH II, 473, “una patera sconservata, di diametro 9/10 di pal. la medesima priva del manico”; Falkener 1852, 72, n., “patera”; Dwyer 1982, 49, i. *Present location*: MANN Reg. Im. 4.10.1847. Not located. *Functional category*: Vessel, ablutions. Probably Tassinari 1997 patera type H.

323 Bronze handle of lid

PAH II, 473, “un manico di un coverchio”. *Present location*: MANN Reg. Im. 4.10.1847. Not located. *Functional category*: Vessel, unknown function.

324 Bronze lock

AC IV, 162 = PAH II, 473, “un lucchetto”; Falkener 1852, 72, n., “parts of lock”; Dwyer 1982, 49, ii. *Present location*: MANN Reg. Im. 4.10.1847. Not located. *Functional category*: Fixture, closure.

325 Bronze pivot hinge

AC IV, 162, “un arpione”; PAH II, 473, “un bilico mancante della piastra”, Falkener 1872, 72, n., “hinge”; Dwyer 1982, 49, iv. *Present location*: MANN Reg. Im. 4.10.1847. Not located. *Functional category*: Fixture, closure (structural door).

326 Bronze coin

AC IV, 162 = PAH II, 473, “una moneta di modulo grande”; Falkener 1852, 72, n., “coin”. *Present location*: MANN Reg. Im. 4.10.1847. Not located. *Functional category*: Instrument, economic.

327 Bronze strap hinge

PAH II, 473, “una piccola sciba a meccione”; Dwyer 1982, 49, iii. *Present location*: MANN *Reg. Im.* 4.10.1847. Not located. *Functional category*: Fixture, closure.

328–329 Two bronze coins

AC IV, 162 = *PAH* II, “una moneta corrosa di modulo mezzano”, “altra di modulo piccolo”. *Present location*: MANN *Reg. Im.* 4.10.1847. Not located. *Functional category*: Instrument, economic.

330 Glass bottle

AC IV, 162 = *PAH* II, 473, “una bottiglia bislunga ad un sol manico e col collo corto, di altezza 1 pal.”; Falkener 1852, 72, n., “three vessels of different shape and colour”; Dwyer 1982, 49, v. *Present location*: MANN *Reg. Im.* 4.10.1847, “bottiglia bislunga ad un sol manico e collo corto”, *SG* written at the margin. *SG*, *Vetri antichi*, 2812, “bottiglia bislunga ad un sol manico e collo corto di altezza palmo uno”. Not located. Dimension: H ca. 26 (*PAH*). *Functional category*: Vessel, storage. Probably a one-handed cylindrical storage bottle Isings 51.

331 Glass bottle

AC IV, 162 = *PAH* II, 473, “altra boccetta a palla, rotta nel collo e nella pancia, di altezza 2/5 di pal.”; Falkener 1852, 72, n., see above; Dwyer 1982, 49, vi. *Present location*: MANN *Reg. Im.* 4.10.1847. Not located. *Dimensions*: H 10.4 (*PAH*). *Functional category*: Vessel, medical/cosmetic. Probably an *unguentarium* with globular or pear-shaped body, Scatozza 41/42/45.

332 Glass plate II.2.10

AC IV, 162 = *PAH* II, 473, “una tazza circolare di color verde, di diametro circa 7/10 di pal.”; Falkener 1852, 72, n., “tazza seven ins. diameter, of a green colour”; Minervini 1854, 21, “una tazza di color verde” (missing in Minervini 1855); Dwyer 1982, 49, vii. *Present location*: MANN *Reg. Im.* 4.10.1847, *SG* written at the margin. *SG*, *Vetri antichi*, 2814. Quite probably *inv. Fiorelli*, 11646. *Functional category*: Vessel, culinary consumption.

333 Terracotta cup

AC IV, 162 = *PAH* II, 473, “una tazza circolare, di diametro 2/5 di pal.”; Falkener 1852, 72, n., “cup”; Dwyer 1982, 50, x. *Present location*: MANN *Reg. Im.* 4.10.1847. Not located. *Dimensions*: D 10.5 (*PAH*). *Functional category*: Vessel, culinary consumption (cup, bowl, or small plate).

334 Terracotta cup

AC IV, 162–163, “altra mancante un pezzo” = *PAH* II, 473, “altra mancante di una porzione, di diametro 7/10 di pal.” *Present location*: MANN *Reg. Im.* 4.10.1847, *SG* written at the margin. *SG*, *Terracotte*, 5293, “scodella verniciata rosacea, con piccola base alta due decimi e mezzo e di diametro sette decimi.” Not located. *Dimensions*: D ca. 18 (*PAH*, *SG*). *Functional category*: Vessel, culinary consumption. From the rather large diameter, and the use of the word ‘tazza’, this is probably a plate rather than a cup. The *SG* mention of a reddish slip might indicate it was some type of *terra sigillata*.

335 Terracotta lamp

AC IV, 163 = *PAH* II, 473, “una lucerna ad un lume”; Falkener 1852, 72, n., “lamp”. *Present location*: MANN *Reg. Im.* 4.10.1847. Not located. *Functional category*: Instrument, lighting.

336 Terracotta pot

AC IV, 163 = *PAH* II, 473, “una pignatta, alta 9/10 di pal.”; Falkener 1852, 72, n., “two terracotta vases”. *Present location*: MANN *Reg. Im.* 4.10.1847. Not located. Dimension: H 24.3 (*PAH*). *Functional category*: Vessel, cooking/storage (a handleless plain or cooking ware *olla*).

337–339 Three terracotta lids

PAH II, 473, “tre coverchiole”. *Present location*: MANN *Reg. Im.* 4.10.1847, “tre coperchi”. Not located. *Functional category*: Vessel, cooking/storage.

340 Terracotta vase

PAH II, 473, “un vasettino di altezza circa 5/10 di pal.”; Falkener 1852, 72, n., see above; Dwyer 1982, 50, ix. *Present location*: MANN *Reg. Im.* 4.10.1847. Not located. *Dimensions*: H 13.5 (*PAH*). *Functional category*: Vessel, unknown function.

R23 LATRINA

The unadorned room is called an *apotheca triclini* by Falkener (p. 79–80),³³ and he mentions a terracotta puteal covering and a rounded large stone as finds. Minervini speaks of a (stone) weight and a terracotta puteal standing in the corner of the room, of which it is not known whether they were found there or elsewhere: “la terza stanza ... vi si vede nell’angolo un pogggiolo forse per lavare (latrina), un peso ed un puteale di terracotta i quali ignoriamo se fossero stati trasportati in questo sito”.³⁴ At the back of the room, there was a latrina.

341 Terracotta puteal

Falkener 1852, 79, “a terra cotta puteal covering was found in one corner or this room”; Minervini 1854, 19 = 1855, 80) “un puteale di terracotta”. *Present location*: Left in Pompeii, in the house. *Functional category*: Architectonic, hydraulic (well-head).

342 Polished black stone (see Fig. 57, p. 115)

Falkener 1852, 80, “large round mass of greenish-black marble, flat on one side, as if used for polishing pavements. It weighs about $\frac{3}{4}$ cwt”; Minervini 1854, 19 = 1855, 80, “un peso”. *Dimensions*: The diameter of the slightly oval stone, is ca 35 cm. A ‘hundredweight’ is ca 50 kg, so $\frac{3}{4}$ of it would be ca 38 kg. *Comments*: The oval, well-polished stone in dark green porphyre may have served a practical purpose such as polishing the pavements, but for its heavy weight this seems unlikely. It may have had a cultic meaning in the garden context. Such stones may have been likened to bethyls, aniconic symbols of gods, and objects of worship. *Bibliography*: Berg *et al.* 2008, 208. *Functional category*: Unknown function (cult object?).

R25 TRICLINIUM

The upper triclinium R25, with delicate white-ground wall-paintings, was, hypothetically, meant for summer use, as it opened towards the garden with a wide door. It was undergoing renovation works at the moment of the eruption, as the centre of its mosaic floor was missing.³⁵ Falkener (78–79) enumerates the finds from this room as two larger transport amphorae, one with an inscription. His ‘three small amphorae’ coincide with the ‘tre anforette ad un manico’ of the *PAH*, although they are actually one-handled urcei. Furthermore, he reports a plate of carbonized olives and ‘several glass vessels’ of unspecified type. The *PAH* omits the transport amphora but mentions the three urcei, and lists the plate with olives under the finds of May 22, thus seemingly deriving from room 9–10, but more probably belonging to this room. Other associated finds not mentioned by Falkener are another bowl with olives, and a glass unguent bottle that might, however, be counted in the ‘glass vessels’ of Falkener. The *Annali civili* do not mention the finds of May 22 at all.

343–345 Three urcei for garum

PAH II, 465, “tre anforette ad un manico, due delle quali hanno dipinta in nero l’epigrafe *LIQUAMEN*, e la terza anche in nero *TVSCOLA*. | ... *ON* | *OFFICINA SCAV*.”; Falkener 1852, 78–79, ‘in this room were found three small amphorae, two of which have painted on them, in black letters *LIQUAMEN OPTIMUM* | *TVSCOLA* | *ON* | *OFFICINA SCAV*’; Minervini 1854, 21 = 1855, 85; Jahn 1857, 198, n. 42. *Present location*: MANN *Reg. Im.* 22.7.1847, *SG* noted at margin. *SG*, *Terrecotte*, 5255–5257. *Inv. Fiorelli*, 17051–17053, “tre anforette ad un manico, due delle quali hanno in nero l’epigrafe *LIQVAMEN OPTIMUM*, la terza anche in nero *TVSCOIANOFFICINASCAV*. L’una manca di manico, l’iscrizione della terza e’ molto incerta. L’altezza di tutte e’ di circa 0,264.” Not located. *Comments*: The form of these ‘anforette’ is most probably the one-handled Schoene–Mau *urceus* type VI. The first two texts read unproblematically *liquamen optimum*, *CIL* IV

³³ Falkener 1852, 79; Minervini 1854, 19; 1855, 80.

³⁴ Minervini 1855, 80.

³⁵ *PAH* II, 465; Panofka 1847 a, 133; Bechi 1852, 13; Falkener 1852, 78–80; Minervini 1854, 17–18; 1855, 65; *PPM* IX, 304–307; Tammisto – Kuivalainen 2008, 99–100.

2590, 2591, also commented on by Minervini 1954, 21 and Jahn (1857, 198, n. 42). The third text, *CIL* IV 2625, which (possibly in addition to *liquamen optimum*) has a longer text, is more problematic. The initial word, *Tuscola*, as read by Falkener, cannot be found in Latin texts or similar inscriptions. Conserving this reading, perhaps a different word division could be considered, resulting in a putative, hypothetical integration [*vetrus cola[tum]*]. However, as the other lines of the inscription were also erased at the beginning and the end, and in the *Inventario San Giorgio* the word was copied differently (TVSCOIA), proving that the reading was indeed precarious, it should be thoroughly questioned. Among the most common *tituli* relative to the products of the most important Pompeian *garum* producer, A. Umbricius Scaurus (for which see Curtis 1984–86, 214, Appendix catalogue, p. 227; Etienne, Mayet 1998; Cappelletto et al. 2013), is the text starting with the abbreviation *G. F. scombri*, i.e. *gari flos* made of *scombrum* fish (for the expression *gari flos*, see Curtis, 1984–1986, 215–219). The initial cursive letters G F, erased, may have been read as T U by an inexpert eye. The long diacritical sign of the G, often to be found in these *tituli*, could have been read as the first line of a U, while the vertical line of the F could have been read as the second line of a V. Thus the missing lines would be the two horizontal lines of the F. In the ending part, the top line of the C, often angular rather than rounded, could have been interpreted as a T. The ending of the line was, according to Falkener ...LA, but ...IA according to the San Giorgio Inventory. It might instead have been an M of the word *sgombri*, the rest of the word having been completely erased. *Functional category*: Vessel, transport/storage.

346 Terracotta transport amphora

Minervini 1854, 21 = 1855, 85; Falkener 1852, 79, “another, larger one, bears the following inscription, in red paint; the dots represent letters which are now illegible: . . ΑΦΑΛ . . . P. I. I. . ΜΗΝΟΔΟΤΥΙ and on the other side, in black paint: KOR OPT the letters KOR being nearly effaced”; Jahn 1857, 198, n. 42; Breton 1855, 318, n. 32. *Present location*: Not located. *Comments*: The inscriptions are published in *CIL* IV 2584. The text, in black letters in Latin, was deciphered by Minervini (1854, 21) as *Kor(cyraeum) opt(inum)*: best quality wine from Corcyra, Corfu. To support his reading, Minervini cited Otto Jahn (1854, 34). Jahn, in his turn, had discussed a passage of Plin. *nat.* 35, 14, 46 praising Adriatic (among which Corcyrean) wine amphorae, and a passage of Hesychios (Ps. Arist. *mir.* 114) relating that the excellent Chian and Thasian wines which were sold in Corcyrean amphoras. Jahn and the ancient authors, however, discuss amphorae as vessels, not the wine contained within. Jahn comments later on this amphora, referring to Minervini (1857, 198, n. 42): “was Minervini... für *Corcyraeum optimum* nehmen vollte”. Other Pompeian amphora *tituli* reading *KOR* (*CIL* IV 6545) or also *POTIO KORIN* (*CIL* IV 6536) have more plausibly been read as *Korinthia*, referring to Corinthian wine instead. Antonio Varone (2010, 220), as well as August Mau in *CIL* IV *Indices*, in fact cite the *titulus* here as evidence for the presence of Corinthian wine in Pompeii. However, Corinthian wine was not particularly famous (harsh wine, Athenaeus 1, 30), while the most renowned luxury Greek *crus* came from Chios and Thasos (for the diffusion and appreciation of Greek wines in Rome, see Komar 2014). The amphora on which the *titulus* was painted has, as represented in the drawing of Falkener, a cylindrical neck, a bead rim, distinct sloping shoulders, no carination, elongated tubular, slightly convex body, and a small, cylindrical toe. Minervini states that the amphora was of Greek origin, and suggests that it was the gift of some Greek person to M. Lucretius. The form, referred to in the *CIL* as *Schöne XIII*, can most closely be compared to the Aegean types from Cos and Rhodes, which were the origin of the Roman Dressel 2–4. However, Coan and Rhodian wines were particularly plebeian by reputation and mass-imported (Komar 2014). The written statement of the contents of the amphora as being either from the Phaeacian island of Corfu (cf. *Iuv.* 15, 25: *corcyrea urna*, of the wine offered to Odysseus by the Phaeacians, which might offer a poetic motivation for the consumption of such ‘mythological’ wine) or from wealthy Corinth would, on the contrary, make it at least something of a rarity. Furthermore, *KOR* for *korinthial/corinthium* would be a preferable reading to *KOR* for *kerkyreal/corcyreum*. The other inscription, in Greek in red letters, confirms further that the wine was probably imported. The inscription, both as transcribed and as copied in the amphora drawing in a more complete form, reads, as suggested by Minervini, ΔΔΠΙ Σεπτίμιου Μηνοδοτου, Jahn (1857, 198–199, n. 42), or less plausibly, Σεπτίμιος Μηνοδοτω. This would refer to a person, possibly a wine merchant of the name Septimius Menodotus, as the commercial dealer of the Greek product. The name Menodotus is also known from

one Pompeian graffito containing just the name, in the Casa del Duca d'Aumale (*CIL* IV 1314). *Functional category*: Vessel, transport/storage.

347 Terracotta transport amphora

Falkener 1852, 79, fig. *Present location*: Unknown, probably left in Pompeii. Not located. *Functional category*: Vessel, transport. In Falkener's drawing, the vessel is depicted as a transport amphora for fish sauces, form Beltràn IIB, from Baetica.

348 Glass unguent bottle

PAH II, 465, "una piccola bottiglia a palla rotta nel collo"; Falkener 1852, 79, "several glass vessels"; Dwyer 1982, 32, v. *Present location*: MANN *Reg. Im.* 22.7.1847. Not located. *Comments*: In the *PAH*, it is included among the finds from ala R9–10. *Functional category*: Vessel, medical/cosmetic.

349 Carbonized olives in terracotta plate

PAH II, 466, "molte oliva carbonizzate in un piatto di terra cotta, in frammenti"; Falkener 1852, 79, "a quantity of carbonized olives in a plate of terra cotta"; Minervini 1854, 21, "un'olla con olive carbonizzate, la quale conservasi nella raccolta delle terrecotte del Real Museo Borbonico" = 1855, 86. *Present location*: MANN *Reg. Im.* 22.7.1847, "Molte olive carbonizzate in un piatto di terracotta ed altre in un recipiente a forma di conca," *SG* noted at margin. *SG*, *Oggetti preziosi*, 191. Not located. *Functional category*: Vessel, culinary consumption, with organic material (plate).

350 Carbonized olives in terracotta bowl

PAH II, 466, "altre [olive] in un recipiente a forma di conca, pure di terracotta e rotta nell'labbro." Borgoncino 2006, 122, cat. 356. *Present location*: MANN *Reg. Imm.* 22.7.1847, *SG* noted at margin. *SG*, *Commestibili*, 191, "molte olive carbonizzate in un recipiente a forma di conca di terracotta tutta rotta nel labbro e mancante. Del diam. circa 1 palmo (9501 cons. provv. Pompei)". *Dimensions*: D 26.5 (*PAH*). *Functional category*: Vessel, culinary consumption, with organic material. A large, open bowl or small basin with out-turned rim.

R26

This open, exhedra-like space was originally decorated with modest wall-paintings.³⁶ Falkener describes the room without mentioning any loose finds, except a pile of lime, and some column drums relative to on-going construction works. They are not mentioned in the *PAH*.

351 Heap of lime

Falkener 1852, 83, "a heap of lime lies under the stairs leading to the upper floor". *Present location*: Pompeii, House of Marcus Lucretius, *in situ*. *Functional category*: Architectural (construction works).

352 Ionic column drums

Falkener 1852, 83, "some frustra of two Ionic columns were also found here; the others in the large room between tablinum and the garden of adjoining house". *Present location*: Pompeii, House of Marcus Lucretius, *in situ*. *Functional category*: Architectural (construction works).

R28 ENTRANCE, FAUCES

Falkener (71), mentions that "In the description of the prothyrum is an account of several objects found there, which must evidently have fallen from the upper floors." However, it was not possible to identify such a list in the *PAH*. The excavation of the entrance n. 24 was started on 16 August, in the belief that it was a separate

³⁶ Falkener 1852, 71; Minervini 1854, 18; Fiorelli 1875, 394.

house: “nella casa, che precede quella così detta delle Suonatrici, il protiro della quale riesce nel vico, ch’è limite della isola.” Of the first find mentioned on this day, a strigil (Cat. 353), Falkener states that it was found ‘from the upper portion of adjoining house’. Quite putatively, all of the finds of this day not specifically mentioned by Falkener as coming from R29 or R30 are here attributed to the entrance fauces R28. They may, however, as well come from any of these rooms.

August 16

353 Bronze strigil

PAH IV, 161, “una strigile lunga quasi un palmo”; *PAH* II, 470, “una strigile di lunghezza pal. 1 circa”; Falkener 1852, 71, “bronze strigil, eight inches long”; Minervini 1854, 20, “una strigile” = 1855, 82. *Present location*: MANN *Reg. Im.* 4.10.1847, erroneously *SG* 2699 signed at the margin. Probably *SG*, *Bronzi minuti*, 2669 “Strigile di bronzo di lunghezza palmo uno circa”. Not located. *Functional category*: Instrument, medical/cosmetic (igiene).

354 Bronze handle

PAH II, 470, “un manico di vase”. *Present location*: MANN *Reg. Im.* 4.10.1847. Not located. *Functional category*: Vessel, unknown function.

355–356 Two bronze handles

PAH II, 470, “due doppii manici, uno de quali rotto in due pezzi”. *Present location*: MANN *Reg. Im.* 4.10.1847. Not located. *Functional category*: Vessel, unknown function.

R29 ATRIUM

The upper part of the house centres around the hall that had previously been the atrium of an older, independent house (IX.3.24), united with the House of Marcus Lucretius by demolishing its rear walls.³⁷ Falkener lists eight objects found ‘in the atrium’ R29 (p. 80, n.). Four of these (Cat. 357–358, 360–361) were undoubtedly found, according to the *PAH*, on August 16, and the ‘casseruola’ can also possibly be identified as the ‘bronze vase’ (Cat. 359), and the ‘iron key’ as the iron nail, ‘chiodo’ (Cat. 362) found then. On this day, excavations were conducted in several rooms, starting from the street entrance of House 24, proceeding through the atrium R29, and finally arriving at the cubiculum R30. The remaining two atrium finds mentioned by Falkener, a glass cup (Cat. 363) and a terra sigillata cup with stamp (II.3.1, Cat. 364), were according to the *PAH* found on August 20.

Falkener also mentions a list of nine objects in a separate group, in addition to a hoard of 23 coins found “in the first recess, or cubiculum of the atrium”, meaning the two rectangular niches of the west wall of the atrium. Seven of these items and the coins are listed in the *PAH* as found on 30 August, the day of extensive excavation in the presence of the Royal Family. Evidently, one of the places left to be uncovered in their presence was the recess of the upper atrium, thought to be promising for finds. The group of recess finds is listed in the *PAH* contiguously, after the finds from the tablinum R33 and cubiculum R32. The pieces missing in the *PAH* lists are a glass unguent bottle (Cat. 365), probably the one found already on 18 August, and the ‘parts of hinges’ (Cat. 396–397), possibly identical to the ones found on 31 August.

August 16, “Nella casa, che precede quella così detta delle Suonatrici, il protiro della quale riesce nel vico, ch’è limite della isola. Nel corso della giornata, all’altezza variata di 4 a 6 pal. si sono rinvenuti li seguenti oggetti”

³⁷ Bechi 1852, 15–16; Falkener 1852, 83–84, n.; Minervini 1854, 18; 1855, 66; Breton 1855, 304; Dwyer 1982, 50; *PPM* IX, 309–310; Fiorelli 1875, 394.

357 Bronze strap hinge

PAH II, 470, “una sciba a meccione”, Falkener 1852, 84, n. “a hinge”. *Present location*: MANN *Reg. Im.* 4.10.1847. Not located. *Functional category*: Fixture, closure (door).

358 Bronze patera

AC IV, 161, “una patera circolare rotta nel manico, del diametro di 6/10 di palmo”; *PAH* II, 470, “una patera circolare rotta nel manico, di diametro 6/10 di pal.”; Falkener 1852, 84, n. “bronze patera, handles broken”. *Present location*: MANN *Reg. Im.* 4.10.1847. Not located. *Dimensions*: D ca 16.0 (*PAH*). *Functional category*: Vessel, ablutions. Probably a ‘patera’ type H, of Tassinari 1997.

359 Bronze ‘casseruola’

AC IV, 161, “una casseruola del diametro di 4/10 palmo”; *PAH* II, 470, “una cazzaruola del diametro di 4/10 di pal.”; Falkener 1852, 84, n. “bronze vase”. *Present location*: MANN *Reg. Im.* 4.10.1847. Not located. *Functional category*: Vessel, pouring liquids (serving/measuring wine). Probably a Tassinari 1997 ‘casseruola’ type G.

360 Bronze lock

PAH II, 470, “una serratura col suo lucchetto”; Falkener 1852, 84, n., “lock”. *Present location*: MANN *Reg. Im.* 4.10.1847, “serratura col suo lucchetto”. Not located. *Functional category*: Vessel, culinary consumption.

361 Lead strainer

PAH II, 470, “una lamina circolare del diametro di 6/10 di pal. pel passaggio d’acqua”; Falkener 1852, 84, “lead-strainer, 4 ½ ins. diameter”; Minervini 1854, 20, “alcuni pezzi di piombo...tutti sono muniti di molti piccoli fori, perché destinati a chiudere le estremità dei tubi egualmente di piombo, onde impedire il passaggio a materie ostruenti, senza però impedire il corso delle acque” = 1855, 84. *Present location*: MANN *Reg. Im.* 4.10.1847, *SG* noted at margin. *SG*, *Bronzi minuti*, 2668, “una lamina di piombo circolare del diametro di once sette e due quinti. Pel passaggio forse dell’acqua.” Not located. *Dimensions*: D 15.9 (*PAH*); 16.5 (*SG*). *Functional category*: Architectural, hydraulic (filter for sewer).

362 Iron nail or key

AC IV, 161 = *PAH* II, 470, “un chiodo”; Falkener 1852, 84, n., “iron key”. *Present location*: MANN *Reg. Im.* 4.10.1847, “Ferro. Un chiodo”. Not located. *Comments*: This could be the large key found in the cella of the *ostiarus*, mentioned by Carlo Pancaldi (1848, 12). However, he had visited the house already a month earlier, on 11 July 1847. *Functional category*: Fixture, closure.

August 20**363** Glass cup

AC IV, 161, “una tazza rotta”; *PAH* II, 471, “una tazza in frammenti”; Falkener 1852, 84, n., “broken glass tazza”. *Present location*: MANN *Reg. Im.* 22.7.1847. Not located. *Functional category*: Vessel, culinary consumption (cup or plate).

364 Terra sigillata plate II.3.1

AC IV, 161, “il fondo di una coppa nel mezzo della quale leggesi FORM (retrogr.) = *PAH* II, 471, “il fondo di una coppa con vernice rossa, nel cui mezzo leggesi FORTVN (retrogr.)”; Falkener 1852, 84, n., “bottom of a terra-cotta cup of red varnish, on which letters FORM, written backwards”; Minervini 1854, 21, “un vaso rosso con epigrafe FORM” = 1855, 85; Dwyer 1982, 50, i. *Present location*: MANN *Reg. Im.* 22.7.1847. *SG*, *Terrecotte*, 5258, “fondo di una coppa con vernice sopra nel cui mezzo leggesi FORTA retr.” *Inv. Fiorelli*, 16654, “Fondo di una coppa con vernice rossa nel cui mezzo leggesi PORTNE retr.” *Functional category*: Vessel, culinary consumption.

Finds in recess/cupboard

August 18, “verso le ore 10 si è rinvenuta, all’altezza di circa 4 palmi dal suolo di un cubicolo”.

365 Glass bottle

AC IV, 161, “una carafinetta”; *PAH* II, 471, “una caraffinetta di vetro”. *Present location*: MANN *Reg. Im.* 22.7.1847. Not located. *Comments*: To be added to the group of four unguent bottles found in the same place on August 30, totalling five glass bottles as mentioned by Falkener 1852, see below. *Functional category*: Vessel, medical/cosmetic.

August 30, Falkener 1852, 84, n., “In first recess, cubiculum of atrium”.

366–388 Twenty-three bronze coins

AC IV, 162 = *PAH* II, 472, “ventitre monete di modulo diverso”; Falkener 1852, 84, n., “twenty-three coins”. *Present location*: MANN *Reg. Im.* 22.7.1847. Not located. *Functional category*: Instrument, economic.

389 Bronze lock

AC IV, 162 = *PAH* II, 472, “un lucchetto”; Falkener 1852, 84, n., “part of a lock”. *Present location*: MANN *Reg. Im.* 22.7.1847. Not located. *Functional category*: Fixture, closure (perhaps from a box, as the diminutive ‘lucchetto’ is used).

390 Bronze ring

AC IV, 162 = *PAH* II, 472, “uno anello”; Falkener 1852, 84, n., “ring”. *Present location*: MANN *Reg. Im.* 22.7.1847. Not located. *Functional category*: Fixture.

391 Glass unguent bottle

AC IV, 162 = *PAH* II, 472, “una piccola boccia a palla”; Falkener 1852, 84, “small spherical vase”. *Present location*: MANN *Reg. Im.* 22.7.1847. Not located. *Functional category*: Vessel, medical/cosmetic. Probably a small globular *unguentarium* Scatozza type 41 or 42.

392–395 Four glass unguent bottles

AC IV, 162, “quattro unguentari, uno de’ quali rotto nel collo” = *PAH* II, 472, “quattro unguentari”; Falkener 1852, 84, “five unguentaria”. *Present location*: MANN *Reg. Im.* 22.7.1847, “quattro unguentari dei quali uno rotto nel collo”. Not located. *Functional category*: Vessel, medical/cosmetic. One ‘caraffinetta’ found on August 18 may complete the group of five. *Unguentaria* of undefined form, plausibly the common Scatozza 46, or 47.

August 31**396–397** Two bronze strap hinges

PAH II, 473, “una sciba a meccione. Altra per metà”, Falkener 1852, 84, n., “parts of hinges”. *Present location*: MANN *Reg. Im.* 4.10.1847. Not located. *Functional category*: Fixture, closure (door).

R30 CUBICULUM

This was a small room with elaborate IV style wall-paintings, and a window opening onto the street.³⁸ Falkener mentions five objects as coming from (83, n.) “the left hand cubiculum” (i.e. the small room east of the upper entrance fauces). His description of the upper atrium area is made as entering from the upper fauces (R27), i.e. left=E, right=W. The same objects appear in the *PAH* (II, 470) among the finds made on August 16.

August 16, *PAH* II, 470: “all’altezza variata di 4 a 6 pal. (at the height of ca. 100–160 cm).

³⁸ *PAH* II, 470; Bechi 1852, 16; Falkener 1852, 83–84, n.; Minervini 1854, 18; 1855, 66; Dwyer 1982, 50–51; *PPM* IX, 310–311.

398 Glass unguent bottle

PAH II, 470, “una boccia a palla a due manici rotta nella pancia, di alt. circa 7/10 di pal.”; Falkener 1852, 83, n., “two glass vessels”; Dwyer 1982, 51, ii. *Present location*: MANN *Reg. Im.* 4.10.1847. Not located. *Dimensions*: H 18.9 (*PAH*). *Comments*: A globular bottle with two handles is a quite uncommon form, as the vessel seems to be too high to be an *aryballos*. *Functional category*: Vessel, medical/cosmetic.

399 Glass bottle

PAH II, 470, “una caraffinetta”; Falkener 1852, 83, n., vedi sopra; Dwyer 1982, 51, iii. *Present location*: MANN *Reg. Im.* 4.10.1847. Not located. *Comments*: Unguent bottle of undefined form, plausibly the common Scatozza 46, or 47. *Functional category*: Vessel, medical/cosmetic.

400 Glass paste disc III.4.3

PAH II, 470, “un pezzo circolare di colore blu del diametro di circa 2/10 di palmo, avente nel mezzo una testa di Medusa in rilievo”; Falkener 1852, 83–84, n., “a circular piece of blue glass, 1 ½ ins. diameter, having a head of Medusa in relief”; Minervini 1854, 21 = 1855, 84, “un pezzo circolare con testa di Medusa a rilievo”; Dwyer 1982, 50, I. *Present location*: MANN *Reg. Im.* 4.10.1847, erroneously SG 2811 noted at margin. *SG, Vetri antichi*, 2809, “pezzo circolare di color bleu del diametro di circa due decimi di palmo, avente nel mezzo una testa di Medusa in rilievo”. *Inv. Fiorelli*, 13648. *Functional category*: Ornament (of a jewelry box?).

401 Terracotta lamp

PAH II, 470, “una lucerna priva del manico”; Falkener 1852, 84, n., “terra-cotta lamp”. *Present location*: MANN *Reg. Im.* 4.10.1847. Not located. *Functional category*: Instrument, lighting.

402 Terracotta lid

PAH II, 470, “un coverchio di pignatta”; Falkener 1852, 84, n., “vase-cover”. *Present location*: MANN *Reg. Im.* 4.10.1847. Not located. *Functional category*: Vessel, cooking/storage.

R31 CUBICULUM

Falkener (1852, 83, n.) lists four items found “in the right hand cubiculum”. Minervini calls this room, decorated with modest linear paintings “cella dell’ostiaro”, and Bechi also supposed that it belonged to the *atriensis*.³⁹ Pancaldi (1848, 12) mentions that the *cella ostiaria* had a window with an iron grate: “In uno dei cubiculi vicino a camera del riposto o magazzino si rinvenne bellissima grande *chiave*, che il *Fiorelli* crede la principale di tutta la casa, e che quivi dormisse il Custode, osservandosi nella finestra che guarda la via una cancellata di ferro.” At present, it is only the other cubiculum on the left (E), R30, that has a window opening onto the street, but originally there were also two windows in R31, blocked up after the excavation. The group of six objects listed in *PAH* II, 474 as being found “in una delle stanze della casa ch’è allegata a quella denominata delle Sonatrici” on September 10, including the objects mentioned by Falkener, has been located here.

September 10**403** Marble plate

PAH II, 474, “il coverchio d’una piccola bocca di pozzo di diametro 4/5 di palmo”; Falkener 1852, 83, n., “(iron portion of a grating) with marble cover”. *Present location*: MANN *Reg. Im.* 4.10.1847. Not located. *Functional category*: Architectural, lid of a cistern.

404 Terracotta weight

PAH II, 474, “un peso”; Falkener 1852, 83, n., “weight”. *Present location*: MANN *Reg. Im.* 4.10.1847. Not located. *Functional category*: Instrument, textile work (loom weight).

³⁹ *PAH* II, 474; Bechi 1852, 16–17; Falkener 1852, 83–84, n.; Minervini 1854, 18; 1855, 66; Breton 1855, 304.

405 Terracotta ring

PAH II, 474, “un anello”; Falkener 1852, 83, n., “ring”. *Present location*: MANN *Reg. Im.* 4.10.1847. Not located. *Functional category*: Unknown.

406 Iron grate

PAH II, 474, “una porzione di cancellata”; Falkener 1852, 83, n., “the iron portion of a grating”; Minervini 1854, 20, “due porzioni di cancelli” = 1955, 83. *Present location*: MANN *Reg. Im.* 4.10.1847. Not located. *Functional category*: Architectural, window grate.

407 Iron lock

PAH II, 474, “una mascatura a cassonetto di larghezza 3/5 di palmo”, Minervini 1854, 20, “tralasciando di far particolare menzione di alcune parti di serrature [in ferro]” = 1855, 83. *Present location*: MANN *Reg. Im.* 4.10.1847, “serratura a cassonetto. Medagliere”. Not located. *Functional category*: Fixture, closure.

408 Part of a Ionic column in tufa

Falkener 1852, 83, “Frustra of two Ionic columns. One ...in the cubiculum on right of prothyrum”. *Present location*: Pompeii, *in situ*. *Functional category*: Architectural.

R32 CUBICULUM

This small cubiculum, opening to the upper atrium R29, was decorated with simple wall-paintings.⁴⁰ Falkener (1852, 84, n.) mentions 13 finds “in cubiculum on left of tablinum”. The *PAH* lists 12 of these as found on August 30, missing only one “cylindrical hinge-socket” (Cat. 415). Only Minervini (1855, 79) mentions fragments of furniture found here, perhaps a bed. A group of undefined metal objects is mentioned both in the *PAH* (II, 472, “chiodi, ed altro”) and by Falkener (84, n., “nails, etc.”).

August 30**409** Small bronze vase

AC IV, 162 = *PAH* II, 472, “un vasettino”; Falkener 1852, 84, n., “small vase”; Dwyer 1982, 52, vi. *Present location*: MANN *Reg. Im.* 22.7.1847. Not located. *Functional category*: Vessel, unknown function.

410 Small bronze vase with sulphur

AC IV, 162 = *PAH* II, 472, “altro [vasettino] con solfo nel di dentro”; Falkener 1852, 84, n., “another [small vase] with sulphur inside”; Minervini 1854, 20, “un piccolo vasetto, che fu trovato ripieno di varii pezzi di zolfo, come tuttavia si osserva” = 1855, 82. *Present location*: MANN *Reg. Im.* 22.7.1847. *SG*, *Bronzi minuti*, 2771, “Vasettino di bronzo con solfo al di dentro, alto once due e due quinti, diametro della bocca once tre”. *Inv. Fiorelli*, 78205, “Vasettino cilindrico contenente dello zolfo. E’ privo di coverchio. Alt. mill. 50. Diam. mill. 65”. *Dimensions*: H 5.0; D 6.5 (*Inv. Fiorelli*); H 5.3; D mouth 6.6 (*SG*). *Comments*: *Inv. Fiorelli* mentions that the vase is missing its lid; this, together with the dimensions, make the identification as a cylindrical *pyxis* quite probable. *Functional category*: Vessel, medical/cosmetic.

411 Bronze mirror

AC IV, 162 = *PAH* II, 472, “uno specchio quadrato rotto in tre pezzi”; Falkener 1852, 84, n., “square mirror”; Minervini 1854, 20, “(due) specchi” = 1855, 82; Dwyer 1982, 51, iii. *Present location*: MANN *Reg. Im.* 22.7.1847. Not located. *Comments*: Plausibly a rectangular bronze mirror, Lloyd-Morgan type A. *Functional category*: Instrument, cosmetic.

⁴⁰ *PAH* II, 472; Bechi 1852, 15; Falkener 1852, 84; Breton 1855, 304; Dwyer 1982, 51–52; *PPM* IX, 312.

412 Top of a bronze candelabrum

AC IV, 162 = PAH II, 472, “una testa di candelabro”; Falkener 1852, 84, n., “top of a candelabrum”. *Present location*: MANN Reg. Im. 22.7.1847. Not located. *Functional category*: Instrument, lighting.

413 Lock plate with nails

AC IV, 162 = PAH II, 472, “uno scudo di serratura di forma circolare, fornito di chiodi”; Falkener 1852, 84, n., “part of a lock”. *Present location*: MANN Reg. Im. 22.7.1847. Not located. *Functional category*: Fixture, closure.

414 Twenty-four bronze rings

AC IV, 162 = PAH II, 472, “n. 24 anelli”; Falkener 1852, 84, n. “twenty-four rings”. *Present location*: Unknown. Not located. *Functional category*: Fixture, unknown.

415 Bronze pivot hinge

Falkener 1852, 84, n., “a cylindrical hinge-socket”. *Present location*: Unknown. Not located. *Functional category*: Fixture, closure (structural door).

416–419 Four bronze probes

AC IV, 162, “quattro tente chirurgiche”; PAH II, 472, “quattro tasti chirurgici”; Falkener 1852, 84, n., “four surgical instruments”; Dwyer 1982, 51, v. *Present location*: MANN Reg. Im. 22.7.1847. SG, *Bronzi minuti*, 2773–2776, “Quattro tasti cerusici di bronzo. Il più grande è lungo once sei e due quinti, il più piccolo once cinque ed un quinto.” *Dimensions*: L between 14.1–11.4 (SG). *Functional category*: Instrument, medical/cosmetic.

420 Bronze sewing needle

AC IV, 162 = PAH II, 472, “un ago da sacco per metà”; Falkener 1852, 84, “sewing needle”; Minervini 1854, 20 = 1855, 82: “un ago da cucire”. *Present location*: MANN Reg. Im. 22.7.1847. Not located. *Functional category*: Instrument, textile work.

Only Minervini 1855:**421** Fragments of furniture

Minervini 1855, 79; Dwyer 1982, 51, i. *Present location*: Unknown. Not located. *Comments*: Possibly remnants of a bed. *Functional category*: Fixture, furniture.

R33 TABLINUM

In the last phase of the house, the original tablinum of the upper house functioned as a thoroughfare between the two parts of the house. It was decorated with relatively elaborate wall-paintings.⁴¹ Falkener mentions as found “in tablinum” only “sixty pieces of a bronze chariot, with four iron felloes”. In the PAH these items appear on August 30. According to Fiorelli, the elements of the chariot were found in the atrium.⁴² Panofka presumes that the stables of the house would have been situated in this area: “La supposizione che da questa parte si trovò lo spazio per il carro e i cavalli...”.⁴³

August 30**422** Sixty bronze elements of a chariot

AC IV, 162 = PAH II, 472, “Sessanta pezzi diversi per guarnizione di un carro”, Bechi 1852, 15, “una biga con

⁴¹ PAH II, 472; Panofka 1847 a, 132; Bechi 1852, 15; Falkener 1860, 84; Minervini 1854, 18; 1855, 66; PPM IX, 312.

⁴² Fiorelli 1875, 394.

⁴³ Panofka 1847 a, 132.

molti ornamenti di bronzo”; Falkener 1852, 84, n., “pieces of a bronze chariot”; Minervini 1854, 20, “Pezzi di bronzo e di ferro che costituivano un carro. Sono questi al n. di circa 60. Appariscono più o meno conservati i cerchi di ferro, destinati a circondar quattro ruote, il che dà la idea di due carri a due ruote, piuttosto che di un solo. E pare che ciò si confermi benanche dalla considerazione, che quei quattro cerchi sono presso a poco eguali di dimensioni. Del resto non sarebbe impossibile che fosse un carro a quattro ruote. Oltre che i cerchi di ferro veggonsi parti degli assi di ferro, e non pochi ornamenti di bronzo di varie forme, a foggia di vasetti, di dischi, di rosoncini ed altrettali” = 1855, 66. Bechi 1852, 15, “in questo tablino si rinvenne una biga con molti ornamenti in bronzo, ora nel real Museo”; Fiorelli 1875, 394, “un carro da trasporto” (in R29); Dwyer 1982, 52, i. *Present location*: MANN *Reg. Im.* 22.7.1847. *SG*, *Bronzi minuti*, 2711–2770, “sessanta nove pezzi diversi di bronzo per guarnizione di un carro. Il più lungo once quattordici, il più piccolo once una e mezza”. Not located. *Dimensions*: L 30.8–3.3 (*SG*). *Comments*: See discussion on p. 193. *Functional category*: Fixture, transport.

423–426 Four iron wheels

AC IV, 162, “quattro grossi cerchi da ruote di carro, tre de’ quali frammentati”; *PAH* II, 472, “quattro cerchioni di ruote di carro, tre de’ quali frammentati”; Falkener 1852, 84, n., “with four iron felloes”, Minervini, vedi sopra. *Present location*: MANN. *Reg. Im.* 22.7.1847, “quattro cerchioni di ruote di carro”, *SG* written on the margin. *SG*, *Bronzi minuti*, 8524–8527. Not located. *Functional category*: Fixture, transport.

R34 CORRIDOR/FAUCES

Falkener (84, n.) lists five objects found ‘in fauces’. Four of these, and six others, appear in the *PAH* on August 17 (II, 470), in ‘fauce’: “Verso le ore 20 l’Architetto Direttore funzionante ha ordinato di sgomberarsi delle terre lo strettoia a destra del tablino della casa in parola, detto altrimenti fauce, onde aversi più facile comunicazione co’ rimanenti membri della stessa casa”. *Annali Civili* confirms (IV, 161): “A man destra del tablino della casa anzidetta”. Only Falkener mentions “ten portions of hinges” found there.

427 Bronze lamp

PAH II, 470, “una lucerna col manico a testa di oca”; Falkener 1852, 84, n., “bronze lamp, with head of a goose”; Dwyer 1982, 52, i. *Present location*: MANN *Reg. Im.* 22.7.1847, *SG* signed at the margin. *SG*, *Bronzi minuti*, 2667, “lucerna di bronzo col manico a testa di oca alta once quattro e quattro quinti per once otto e quattro quinti lunghezza col manico”. Not located. *Dimensions*: H 2.5; L 11.5. *Comments*: Dwyer confuses the lamp with the second bronze lamp found in the house, with a head of cock, see Cat. 256. The general type of both is Loeschke XX/Valenza III, among which the goose head variant is the commonest. *Functional category*: Instrument, lighting.

428 Eight bronze studs

AC IV, 161 = *PAH* II, 470, “otto borchie di forme differenti”. *Present location*: MANN *Reg. Im.* 22.7.1847. *SG*, *Bronzi minuti*, 8421. Not located. *Functional category*: Fixture.

429 Lock plate and lock

AC IV, 161, “una serratura col lucchetto”; *PAH* II, 470, “una mascatura col suo lucchetto”. *Present location*: MANN *Reg. Im.* 22.7.1847. *SG*, *Bronzi minuti*, 8428. Not located. *Functional category*: Fixture, closure.

430–433 Four bronze nails

AC IV, 161 = *PAH* II, 470, “quattro chiodi”. *Present location*: MANN *Reg. Im.* 22.7.1847. Not located. *Functional category*: Fixture.

434 Bronze lock

AC IV, 161 = *PAH* II, 470, “un lucchetto”; Falkener 1852, 84, “lock”. *Present location*: MANN *Reg. Im.* 22.7.1847. Not located. *Functional category*: Fixture.

435 Bifid bronze fitting

AC IV, 161 = *PAH II*, 470, “altro pezzo a coda di rondine”. *Present location*: MANN *Reg. Im.* 22.7.1847. Not located. *Functional category*: Fixture.

436–437 Two bronze pivot hinges with bases

AC IV, 161, “due grandi arpioni”; *PAH II*, 470, “due grandi bilici diunita alle corrispondenti piastre”. *Present location*: MANN *Reg. Im.* 22.7.1847. Not located. *Functional category*: Fixture, closure (structural door).

438 Iron bar/pole

AC IV, 161 = *PAH II*, 470, “forse una staffa di carro”; Falkener 1852, 84, “portion of an iron chariot-pole(?)”. *Present location*: MANN *Reg. Im.* 22.7.1847. *SG*, *Bronzi minuti*, 2666, “staffa di ferro per carro”. Not located. *Functional category*: Fixture, transport.

439 Nine terracotta rings

AC IV, 161 = *PAH II*, 470, “nove anelli”; Falkener 1852, 84, “nine terra-cotta rings”. *Present location*: MANN *Reg. Im.* 22.7.1847. *SG*, *Terrecotte*, 5284. Not located. *Functional category*: Unknown.

UNKNOWN LOCATION

It is impossible to define the place of discovery for the following finds (62 catalogue entries), made between August 21 and 30 in the rear part of the house. The finds appear in the *PAH* without any specified location, and they were not mentioned by Falkener.

August 21, *PAH II*, 471, “all’altezza di circa 4 palmi al di sopra del suolo di una piccola stanza”; *AC IV*, 161 “dappresso a una piccola stanza”. At height of ca. 104 m, in a small room (in one of the rooms around atrium R29).

440 Bronze cup

AC IV, 161 “una coppa”; *PAH II*, 471, “una coppa in bronzo sconservata”. *Present location*: MANN *Reg. Im.* 4/10/1847 “coppa sconservata”. Not located. *Functional category*: Vessel, unknown function.

August 27, *PAH II*, 471, “all’altezza di circa di circa pal. 10 nel suindicato lavoro”. Presumably in the rooms surrounding the upper atrium R29.

441 Bronze coin

AC IV, 161 = *PAH II*, 471, “moneta di modulo mezzano”. *Present location*: MANN *Reg. Im.* 4/10/1847, “moneta di modulo mezzano”. Not located. *Functional category*: Instrument, economic.

442 Terracotta lamp, bilychne

AC IV, 161 = *PAH II*, 471, “lucerna a due lumi col manico rotto”. *Present location*: MANN *Reg. Im.* 4/10/1847, “lucerna a due lumi col manico rotto”. Not located. *Functional category*: Instrument, lighting.

443 Glass bottle

AC IV, 161 = *PAH II*, 471, “una caraffinetta rotta nel collo”. *Present location*: MANN *Reg. Im.* 4/10/1847, “caraffinetta rotta al collo”. Not located. *Comments*: An unguent bottle of undefined form, possibly the most common Scatozza 46 or 47. *Functional category*: Vessel, medical/cosmetic.

August 30, not possible to give location (R11–14/R29/R32/R33/house IX 3, 2).

444–446 Three bronze vases

PAH II 472, “due pignatte, la prima alta pal. 1, la seconda alta pal. 1 3/10. Altra più piccola con coverchio, alta circa 4/5 di palmo.” *Present location*: MANN *Reg. Im.* 22.7.1847. Not located. *Dimensions*: 444) H 25.5; 445) H 34; 446) 21 (*PAH*). *Functional category*: Vessel, cooking. Possibly belongs to kettles/cauldrons type Tassinari U, or ‘secchie’ X.

447 Bronze boiler

PAH II, 472, “una caldaia a due manici con coverchio, alta pal. 2 fino alla estremità superiore del detto coverchio”. *Present location*: MANN *Reg. Im.* 22.7.1847. Not located. *Dimensions*: H with lid 52.0 (*PAH*). *Functional category*: Vessel, cooking. ‘Caldaia’ should mean a round bottomed cooking vessel for boiling water, Type V 1000 (ventre troncoconico o cilindrico) of Tassinari 1997. This object is described as having two handles, and the height is measured to the top of lid, meaning that it is raised above the vessel itself. Only one example in this category, amongst Tassinari’s material, is 53 high, whereas the norm is only half of this.

448 Bronze pot

PAH II, 472, “una pignatta cilindrica di diametro circa 1 pal., alta ½ pal.” *Present location*: MANN *Reg. Im.* 22.7.1847. *SG*, *Bronzi minuti*, 2664, “pignatta cilindrica. Diametro nella bocca once undici; alta once sei e mezzo. Consegna provvisoria 759”. Not located. *Dimensions*: D 26.0; H 13.0 (*PAH*); D bocca 22; H 13 (*SG*). *Functional category*: Vessel, probably for cooking. A “cylindrical pignatta-pot” may refer to a kettle of Tassinari type U1000, with straight vertical walls.

449–451 Three bronze vases

PAH II, 472, “tre oleari co’manici dissaldati”. *Present location*: MANN *Reg. Im.* 22.7.1847. Not located. *Functional category*: Vessel, pouring liquid (probably water). The word ‘oleario’ can describe both jugs and amphorae, probably with narrowing neck, not to be associated with oil. Could be Tassinari 1997 type E, or a pelike-type vase A.

452 Bronze ‘casseruola’

PAH II, 472, “una cazzaruola col manico di diametro ½ pal.” *Present location*: MANN *Reg. Im.* 22.7.1847. Not located. *Dimensions*: D ca. 13.0 (*PAH*). *Functional category*: Vessel, pouring liquid (serving/measuring wine?). Probably Tassinari 1997 ‘casseruola’ type G

453 Bronze ‘casseruola’

PAH II 472, “altra simile [cazzaruola] di diametro circa 4/5 di pal.” *Present location*: MANN *Reg. Im.* 22.7.1847. Not located. *Dimensions*: D 20.8 (*PAH*). *Functional category*: Vessel, pouring liquid (serving/measuring wine?). Probably Tassinari 1997 ‘casseruola’ type G.

454 Bronze vessel

PAH II, 472, “un vase a due manici dissaldati, alto 4/5 pal.” *Present location*: MANN *Reg. Im.* 22.7.1847. Not located. *Dimensions*: H 20.8 (*PAH*). *Functional category*: Vessel of unknown function. The vessel, called with an exceptional name ‘vase’, is of ca 20 cm height, with two handles, and may be a small amphora of Tassinari 1997 type A.

455–457 Three bronze bolts

PAH II, 472, “tre perni forati alto ognuno 4/5 di pal.” *Present location*: MANN *Reg. Im.* 22.7.1847 (erroneously given there as *SG* 8661–8663). *SG*, *Bronzi minuti*, 2661–2663, “tre perni forati. Lungo ognuno once dieci e mezzo”. Not located. *Dimensions*: H 20.8 (*PAH*); 21.0 (*SG*). *Functional category*: Fixture of unknown function, probably transport (wagon) or closure (door).

458 Bronze boiler

PAH II, 472, “altra più piccola di diametro circa 7/10 di pal., entrambe in un fornello di ferro”. *Present location*: MANN *Reg. Im.* 22.7.1847. Not located. *Dimensions*: D 18.9 (*PAH*). *Functional category*: Vessel, cooking (or boiling water).

459 Bronze basin

AC IV, 161–162 = *PAH* II, 472, “una conca bislunga con coverchio, sul quale evvi un manico dissaldato: la

medesima è di altezza circa $\frac{4}{5}$ di pal., compresovi la spessezza di uno de due semicerchi, che gli servivan per base, quali veggonsi dissaldati”. *Present location*: MANN *Reg. Im.* 22.7.1847. *SG*, *Bronzi minuti*, 8459, “conca di bronzo bislunga col coverchio sul quale evvi un manico dissaldato alta once nove e mezzo compresa la spessezza du uno de due semicerchi che le servivano di base, i quali sono dissaldati.” Not located. *Dimensions*: H 20.8 (PAH). *Functional category*: Vessel, ablution/hygiene. An oval basin with out-turned, wide horizontal rim, Tassinari 1997 oval basin type T.

460 Bronze basin

AC IV, 162 = PAH II, 472, “altra simile [conca] mal sana, e con un solo manico, ch’è dissaldato; la medesima è lunga pal. 1 $\frac{3}{10}$ ”. *Present location*: MANN *Reg. Im.* 22.7.1847. *SG*, *Bronzi minuti*, 8460, “altra simile conca, lunga palmo uno ed once tre e mezzo, alta mezzo palmo”. *Dimensions*: L 34,1; H ca 13.2 (PAH). *Functional category*: Vessel, ablutions/hygiene. Tassinari 1997 oval basin type T.

461 Bronze stud

PAH II, 472, “una borchia”. *Present location*: MANN *Reg. Im.* 22.7.1847. Not located. *Functional category*: Fixture (decorative).

462 Terracotta (gypsum?) box

PAH II, 472, “un cassetto di forma singolare”. *Present location*: MANN. *SG*, *Terrecotte*, 5261, “piccola tazza di gesso o piuttosto base rettangolare col lato maggiore di circa once quattro”. Not located. *Dimensions*: L 8.8 (SG). *Comments*: This vase is described as exceptional for its form in the PAH: a small box, ‘cassetto’. The SG describes it as a ‘rectangular cup/plate’, and as made of gypsum rather than terracotta. *Functional category*: Vessel, unknown function.

463 Iron plane III.3.1

AC IV, 162, “una piccola pialla da falegname”; PAH II, 472, “una piccola piana di falegname”; Minervini 1854, 20, “Trovasi la pialla figurata nella nostra tav. IV fig. 9, ed apparisce di forma somigliantissima a quella dei moderni artefici. Solo è a notare che la pialla pompeiana è assai più pesante, perché grave di ferro; e servir dovea per levigare grossi pezzi di legname assai duro e scabro: e senza dubbio era poco maneggevole.” = 1855, 83; Ceci 1858, pl. X, fig. 1. *Present location*: MANN *Reg. Im.* 22.7.1847. *SG*, *Bronzi minuti*, 8787. *Inv. Fiorelli*, 71964, “Altra pialla da falegname più ben conservata col suo ferro tagliente intero. Essa come la precedente è di legno rivestito esternamente in tre lati di lamina di ferro. Lunga mill. 112, Alta mill. 52, Larga mill. 60. Cit. *Inv.* 2787.” The *Registro Immissioni* gives the SG number 2787 for the piece in House of Marcus Lucretius, whereas the *inv. Fiorelli* connects the published piece to SG 8787, surely an erroneous number, as it does not correspond to a plane. *Functional category*: Instrument, hardware tool (carpentry).

464–465 Two iron hoes

AC IV, 162 = PAH II, 472, “due zappe”; Minervini 1854, 20, “due zappe (*ligones*)” = 1855, 83. *Present location*: MANN *Reg. Im.* 22.7.1847, *SG* written at the margin. *SG*, *Bronzi minuti*, 8393–8394, “Due zappe di ferro. Lunga once dieci la prima ed once nove la seconda.” Not located. *Dimensions*: L 22.0; 19.8 (SG). *Functional category*: Instrument, hardware tool (agriculture).

466 Iron hammer

AC IV, 162 = PAH II, 472, “un martello”; Minervini 1854, 20, “una martellina (*malleus*)” = 1855, 83, “una martelletta”. *Present location*: MANN *Reg. Im.* 22.7.1847. Not located. *Functional category*: Instrument, hardware tool (carpentry).

467–468 Two iron pruning knives

AC IV, 162 = PAH II, 472, “due ronche”; Minervini 1854, 20, “due ronche (*runcones*)” = 1855, 83. *Present location*: MANN *Reg. Im.* 22.7.1847, *SG* written at the margin. *SG*, *Bronzi minuti*, 8395–8397, “Due ronche di ferro ad una delle quali è attaccata una raschiatoia. La prima compresa la raschiatoia lunga palmo uno ed once cinque, la seconda lunga once dieci”. *Dimensions*: L 37.5 and 22.0 (SG). *Functional category*: Instrument, hardware tool (agriculture).

469–470 Two iron scrapers/chisels

AC IV, 162 = PAH II, 472, “...ad una delle quali è attaccato una raschiatoia. Altra raschiatoia per metà”. *Present location*: MANN *Reg. Im.* 22.7.1847. Not located. *Comments*: Probably a scalpel. Attached to one of the pruning knives above Cat. 468. *Functional category*: Instrument, hardware tool (carpentry).

471 Iron pick-axe

AC IV, 162 = PAH II, 472, “un piccone”; Minervini 1854, 20, “un grosso pezzo di ferro in parte ossidato forse un piccone (*upupa*)” = 1855, 83. *Present location*: MANN *Reg. Im.* 22.7.1847, SG written at margin. SG, *Bronzi minuti*, 8398, “Un piccone di ferro. Lungo palmo uno ed once cinque.” Not located. *Dimensions*: L 37.5 (SG). *Functional category*: Instrument, hardware tool (agriculture).

472–473 Two iron nails

AC IV, 162 = PAH II, 472, “due chiodi uncinati”. *Present location*: MANN *Reg. Im.* 22.7.1847. Not located. *Functional category*: Fixture. It is not clear what the expression “hooked” nail means.

474 Iron pole

AC IV, 162 = PAH II, 472, “un lungo perno con grappa aderente”. *Present location*: MANN *Reg. Im.* 22.7.1847, erroneous SG 8403 written at the margin. SG, *Bronzi minuti*, 2786, “un lungo perno con grappa aderente, lungo palmo uno, ed once otto e mezza”. Not located. *Dimensions*: L 45.2 (SG). *Functional category*: Fixture, unknown function. The object, described as “an iron pole with an attached cramp” may have been a part of the chariot, or door closure system.

475 Eight iron rings

AC IV, 162 = PAH II, 472, “otto piccolo cerchi, cinque de’quali con perni aderenti”. *Present location*: MANN *Reg. Im.* 22.7.1847. Not located. *Functional category*: Fixture, unknown function.

476 Bone tessera

AC IV, 162 = PAH II, 472, “una tessera col numero VIII”, Minervini 1854, 20, “una tessera col num. XIII” = 1855, 84. *Present location*: MANN *Reg. Im.* 22.7.1847, “una tessera col n. VIII”, SG written at the margin. SG, *Bronzi minuti*, 2679. *Inv. Fiorelli*, 77136. Not located. *Functional category*: Instrument, entertainment (gaming counter).

477 Bone ring

PAH II, 472, “un piccolo ornamento circolare frammentato”. *Present location*: MANN *Reg. Im.* 22.7.1847. Not located. *Functional category*: Probably a fixture for furniture.

478 Bead in glass paste

PAH II, 472, “un bottone”. *Present location*: Not located. *Functional category*: Instrument, entertainment. Probably a gaming counter, rather than a bead for necklace, as it is described as a “button”.

479 Stone weight

PAH II, 472, “un piccolo peso”. *Present location*: MANN *Reg. Im.* 4.10.1847. Not located. *Functional category*: Instrument, weighing.

August 31. Additional finds, picked up from the earth removed the preceding day

480 Bronze boiler

PAH II, 473, “una caldaia priva di manico del diametro di 1 pal.” *Present location*: MANN *Reg. Im.* 4.10.1847. Not located. *Dimensions*: Diam. 26.4. *Comments*: Could possibly have been Tassinari V 3000, a common type of cauldron with one handle and a lenticular body. *Functional category*: Vessel, cooking (boiling water?).

481 Bronze boiler

PAH II, 473, “altra più piccola di diametro circa ½ pal.” *Present location*: MANN *Reg. Im.* 4.10.1847. Not located. *Dimensions*: Diam. 13.2 (PAH). *Comments*: Could possibly have been Tassinari U, a common type of olla-shaped cauldron or a *situla* X. *Functional category*: Vessel, cooking (boiling water?).

482 Bronze vase

PAH II, 473, “una pignatta alta 9/10 di pal. col manico di ferro ossidato”. *Present location*: MANN *Reg. Im.* 4.10.1847. Not located. *Dimensions*: H 24.3 (*PAH*). *Comments*: The one iron handle suggests a bucket with an arched handle, type Tassinari X, globular or ovoid buckets. *Functional category*: Vessel, pouring (water). Possibly also for boiling water.

483 Bronze lock

PAH II, 473, “una piccolissima serratura colla corrispondente mappa”. *Present location*: MANN *Reg. Im.* 4.10.1847. Not located. *Functional category*: Fixture, closure (container).

484 Bronze fitting

PAH II, 473, “una guarnizione di mobile”. *Present location*: MANN *Reg. Im.* 4.10.1847. Not located. *Functional category*: Fixture, furniture.

485–487 Three bronze coins

PAH II, 473, “due monete di modulo mezzano”, “altra di modulo piccolo”. *Present location*: MANN *Reg. Im.* 4.10.1847. Not located. *Functional category*: Instrument, economic.

488 Fragments of lead

AC IV, 162, “due piccioli frammenti”; *PAH* II, 473, “due piccoli frammenti”; Minervini 1854, 20, “alcuni pezzi di piombo, tra’quali avviene uno conformato a guisa di una patera, e tutti sono muniti di molti piccoli fori” = 1855, 84. *Present location*: MANN *Reg. Im.* 4.10.1847. Not located. *Functional category*: Function unknown, possibly parts of sewer strainer, if the description of Minervini (a *patera*-shaped perforated piece) is correct.

489 Terracotta jug

AC IV, 162, “un oleario ad un manico”; *PAH* II, 473, “un’oleario ad un manico”. *Present location*: MANN *Reg. Im.* 4.10.1847. Not located. *Comments*: One-handled terracotta pot. The word ‘oleario’ or ‘oleario’ may refer to vases with pelike-shaped bodies. *Functional category*: Vessel, pouring. May have served in storage.

490 Terracotta jug

PAH II, 473, “una langella ad un manico”. *Present location*: MANN *Reg. Im.* 4.10.1847, “langella a due manici”. Not located. *Comments*: The word ‘langella’ may refer to a *lagynos*-shaped one-handled plain ware jug. *Functional category*: Vessel, pouring. May have served in storage.

491 Terracotta vase

AC IV, 162 = *PAH* II, 473, “un vase a due manici con bocca larga”. *Present location*: MANN *Reg. Im.* 4.10.1847. Not located. *Functional category*: Vessel, cooking/storage.

492 Terracotta lamp

AC IV, 162 = *PAH* II, 473, “una lucerna col manico rotto”; Minervini 1854, 20, “una lucerna [in ferro]” = 1855, 83. *Present location*: MANN *Reg. Im.* 4.10.1847. Not located. *Functional category*: Instrument, lighting.

493 Terracotta weight

AC IV, 162 = *PAH* II, 473, “un peso”; Minervini 1854, 20, “un peso [in ferro]”? = 1855, 83. *Present location*: MANN *Reg. Im.* 4.10.1847. Not located. *Functional category*: Instrument, weighing (loom weigh).

494–497 Four terracotta bases

AC IV, 162, “quattro basette di vase”; *PAH* II, 473, “quattro basette di vasi”; Minervini 1854, 20, “quattro basette [in ferro]” = 1855, 83. *Present location*: MANN *Reg. Im.* 4.10.1847. Not located. *Functional category*: Unknown function.

498 Terracotta fragment with titulus

AC IV, 162, “un frammento di vaso con talune lettere tracciate di nero”; *PAH* II, 473, “un frammento di un vase con alcune lettere tracciate di nero”; Minervini 1854, 20, “un frammento con alcune lettere [in ferro]” = 1855, 83. *Present location*: MANN *Reg. Im.* 4.10.1847, *SG* written at the margin. *SG*, *Terrecotte*, 5254, “Frammento di un vaso con alcune lettere tracciate in nero”. Not located. *Functional category*: Vessel, unknown function.

499–500 Two terracotta lids

PAH II, 472, “due coverchi di pignatta”. *Present location*: Not located. *Functional category*: Vessel, cooking/storage.

September 1**501** Bronze coin

AC IV, 162 = *PAH* II, 473, “una moneta di modulo mezzano”. *Present location*: MANN *Reg. Im.* 4.10.1847. Not located. *Functional category*: Instrument, economic.

502 Bronze fitting

AC IV, 162 = *PAH* II, 473, “una guarnizione di mobile”. *Present location*: MANN *Reg. Im.* 4.10.1847. Not located. *Functional category*: Fixture, furniture.

Finds by Room

For the objects, the following abbreviations are used: br=bronze, gl=glass, ir=iron, ma=marble, tc=terracotta, ts=terra sigillata; *=probably upper floor

Room	Objects (function/quantities/Cat. nr.)
R1 fauces	Total quantity 7 (probably all from the upper floor). Closure 2: strap-hinge br (Cat. 5*); lock br (Cat. 6*). Consumption (culinary?) 2: cup/plate TS (Cat. 2*); cup/plate tc (Cat. 3*). Medical/cosmetic 1: unguent bottle gl (Cat. 7*). Pouring/ablutions 1: handle br (Cat. 4*). Writing? 1: vase (ink-well/moneybox?) tc (Cat. 1*).
R2 atrium	Total quantity 40 (29+11 upper floor). Architectural 5: groups of ceiling fragments (Cat. 18, 26, 46*), floor mosaic fragments (Cat. 47*), revetments plates ma (Cat. 14). Closure 5: 4 strap-hinges br (Cat. 9, 33, 34, 36*), a group of 10 cylinder hinges bn (Cat. 19). Consumption (culinary?) 2: base tc (Cat. 12), cup gl (Cat. 35). Economic 3: 3 coins br (Cat. 15, 37*, 38*). Fixture 11: 5 nails ir (Cat. 22, 23, 24, 25, 43*), 6 nails br (Cat. 28, 29, 30, 31, 32, 39*). Furniture 2: fitting bn (Cat. 40*), table ma (Cat. 44*). Medical/cosmetic 4: spatula bn (Cat. 8), spoon bn (Cat. 41*), unguent bottle gl (Cat. 16), vase tc (Cat. 42*). Lighting 3: <i>candelabrum</i> foot br (Cat. 10), <i>candelabrum</i> base br (Cat. 11), lamp tc (Cat. 20). Organic 1: human skull (Cat. 27). Plastic figure/art 2: sculpture ma (Cat. 13), support ma (Cat. 45*). Pouring/ablutions 1: handle tc (Cat. 21). Tools 1: hammer ir (Cat. 17).
R3 cella ostiaria	Finds mixed with R4.
R4 cubiculum	Total quantity 48. Ablutions/pouring 2: handle? br (Cat. 68), bowl br (Cat. 49). Closures 17: 4 lock plates br (Cat. 51, 52, 53, 54), 5 strap hinges br (Cat. 55, 56, 57, 58, 59), 4 locks br (Cat. 60, 61, 62, 63), 4 pivot hinges br (Cat. 64, 65, 66, 67). Consumption (culinary?) 10: 2 mugs tc (Cat. 73, 74), 3 cups tc/ts? (Cat. 75, 76, 77), 2 cups on pedestals gl (Cat. 90, 91=II.2.1-4), spoon gl (Cat. 92=II.2.5), cup gl (Cat. 93), strainer br (Cat. 50). Economic 2: coin br (Cat. 71), money-bank tc (Cat. 72=III.4.4). Fixtures 1: ring br (Cat. 70). Furniture 1: ornament br (Cat. 69). Medical/cosmetic 7: knife bn (Cat. 78), blue pigment (Cat. 95), unguent bottles gl (Cat. 85, 86, 87, 88, 89). Organic 1: horn (Cat. 79). Ornament 1: ring gold (Cat. 48=III.4.1). Plastic figure/art 1: bust of Bacchus ma (Cat. 94=1.1.). Tools 5: 2 pruning knives ir (Cat. 83, 84), axe ir (Cat. 80), 2 knives (Cat. 81, 82)
R5 cubiculum	Total quantity 28. Closures 6: lock plate br (Cat. 116, 117 121), lock br (Cat. 120), pivot hinge br (Cat. 97, 98). Fixtures 1: nail ir (Cat. 118). Medical/cosmetic 19: tweezers br (Cat. 99, 100), scalpel br/ir (Cat. 101, 102, 103, 104, 105, 106=III.2.1-2). Probe with hook br (Cat. 107, 108=III.2.3), cylindrical container br (Cat. 109, 110, 111, 112, 113, 114, 123), phallus br (Cat. 115=III.2.6), <i>coticula</i> ma (Cat. 116). Lighting 1: <i>candelabrum</i> br (Cat. 96). Writing 1: inkwell br (Cat. 119).

R6 cubiculum	Total quantity 10. Architectural: transparent talcum plates (Cat. 130). Consumption (culinary) 2: 2 cups gl (Cat. 126, 129=II.2.8). Fixtures 1: a group of 10 studs (Cat. 125). Lighting 1: lantern br (Cat. 131=III.1.1). Pouring 2: 2 <i>askoi</i> gl (Cat. 127=II.2.6, 128=II.2.7). Storage 2: 2 bottles gl (Cat. 132, 133). Weighing 1: scales br (Cat. 124).
R7 cubiculum	Total quantity 5. Organic 1: mutton bones (Cat. 136). Storage 2: 2 transport <i>amphorae</i> tc (Cat. 137, 138). Unknown function 2: Vessel br (Cat. 134), vessel gl (Cat. 135).
R8 ala	Total quantity 9. Closure 2: 2 strap hinges br (Cat. 146, 147). Cooking 1: pan/plate br (Cat. 142). Fixture 1: ring br (Cat. 145). Furniture 1: fitting br/wood (Cat. 140). Medical/cosmetic 1: tweezer br (Cat. 144=III.2.7). Heating 1: fire shovel br (Cat. 143). Organic 1: human bones (Cat. 141). Plastic figure/art 1: statuette of Bes tc (Cat. 139=I.2.10).
R9 ala	Total quantity 7. Closure 5: 3 strap hinges br (Cat. 153, 154, 155), 2 pivot hinges (Cat. 150, 151). Furniture 1: ornament br (Cat. 149). Pouring/ablutions 1: patera br (Cat. 148=II.1.3).
R10 cella/ storeroom	Possible finds mixed with R9.
R11 passage R12 utilitarian R13 latrina R14 kitchen	Total quantity 64. Closure 10: 2 keys br (Cat. 159–160), key ir (Cat. 181), 4 lock plates br (Cat. 167–170), strap hinge br (Cat. 188), lock br (Cat. 191), bolt ir (Cat. 182). Consumption (culinary) 6: 3 mugs tc (Cat. 179–180, 202), cup gl (Cat. 193), spoon bn (Cat. 214), strainer br (Cat. 185). Cooking/food preparation 4: pan tc (Cat. 203), mortar and pestle ma (Cat. 156–157), funnel br (Cat. 187). Cooking/heating 1: cauldron br/ir (Cat. 215). Cooking/storage 2: lid tc (Cat. 205), bottle gl (Cat. 177). Entertainment 3: 2 tesserae bn (Cat. 211–212), a group of 26 discs bn (Cat. 216). Fixtures 5: ring tc (Cat. 201), 4 nails br (Cat. 173–175, 189). Furniture 3: a group of rings and ornaments br (Cat. 163), handle br (Cat. 171), ornament br (Cat. 190). Medical/cosmetic 6: mirror br (Cat. 166=III.2.9), spatula bn (Cat. 217), 3 unguent bottles gl (Cat. 176, 178, 192), aryballos br (Cat. 186). Lighting 5: <i>candelabrum</i> plate br (Cat. 164), lantern wick br (Cat. 172), 3 lamps tc (Cat. 206–208). Plastic figures/art 9: 9 statuettes tc (Cat. 194=I.2.4, 195=I.2.1, 196, 197=I.2.7, 198=I.2.6, 199=I.2.8, 200=I.2.5, 209=I.2.9, 210). Pouring/ablutions 2: patera br (Cat. 218), jug tc (Cat. 204). Religion 1: altar st (Cat. 184). Tessile work 1: spindle bn (Cat. 213). Tool 1: scraper ir (Cat. 155). Unknown function 2: 2 vessels br (Cat. 162, 165). Weighing 3: 2 weights br (Cat. 158, 161), weight st (Cat. 183).
R15 tablinum	Total quantity 9. Architectural: 3 groups of ceiling fragments in gilded stucco (Cat. 220, 222, 223), water pipe lead (Cat. 225), gutter with lionhead tc (Cat. 226), antefix tc (Cat. 227). Economic: coin br (Cat. 224). Plastic figure/art: 2 statuettes/wall decoration tc/stucco (Cat. 219=I.2.3, 221=I.2.2).

R16 triclinium	Total quantity 8. Closure 3: 3 pivot hinges br (Cat. 229–231). Consumption (culinary) 1: cup tc (Cat. 233). Entertainment 1: dice bn (Cat. 232). Fixtures 1: nail head br (Cat. 234). Furniture 1: bench with eight silvered legs (Cat. 228). Organic 1: skeleton (Cat. 235).
R17 fauces	Total 1. Organic: skeleton (Cat. 235).
R18 viridarium	Total 87 (51 + upper floor 36). Ablutions/toilet 1: basin br (Cat. 286*). Closure 17: 5 strap hinges br (Cat. 242, 244, 248–249, 276), 3 locks br (Cat. 250, 295*–296*), 2 locks ir (Cat. 314*–315*), 2 lock plates br (Cat. 260, 297*), 4 pivot hinges br (Cat. 260–261, 275, 297bis), latch br (Cat. 292*). Consumption (culinary) 3: cup gl (Cat. 265), cup tc (Cat. 266) mug tc (Cat. 290*). Economic 5: moneybox tc (Cat. 279), with 3 coins br (Cat. 280–282), coin br (Cat. 299*). Fixtures 7: nails br (Cat. 245–246, 293*, 300*–301*), stud br (Cat. 259, 308*). Furniture 8: 8 fittings br (Cat. 263, 298*, 310*–313*), fitting bn (Cat. 267), handle br (Cat. 287*). Religion 1: altar tc (Cat. 273) Medical/cosmetic 2: unguent bottle gl (Cat. 264), bleeding cup br (Cat. 309*=III.2.8). Lighting 3: 2 lamps br (Cat. 258, 319*), lamp tc (Cat. 284). Ornament 2: <i>fibula</i> br (Cat. 243), bracelet br (Cat. 305*). Plastic figures/art 27: sculptures ma (Cat. 236–241=I.1.2, I.1.6, I.1.9, I,1,11–13. 247=I.1.7, 251–256=I.1.4, I.1.8, I.1.14–17, 268–271=I.1.1, I.1.3, I.1.5, I.1.10, 278=I.1.20, 268–271=I.1.1, I.1.3. I.1.5. I.1.10, 278=I.1.20, 288*=I.1.18), 6 <i>oscilla</i> ma (Cat. 283=I.1.25, 289*=I.1.21, 294*=I.1.22, 302*=I.1.25, 320–321=I.1.22–23*), statuette tc (Cat. 272), stucco relief (Cat. 285). Pouring 4: casseruola br (Cat. 257), 2 amphorae br (Cat. 274=II.1.1, 303*=II.1.2), bucket br (Cat. 304*). Transport 7: bell br (Cat. 307*), horse bit br (Cat. 306*), 5 carriage bars ir (Cat. 316*–318*). Unknown function 1: hook br (Cat. 277). Weighing 1: beam of scales br (Cat. 291).
R19 small exedra	The finds from R19 and R20 have been registered together. Total quantity 19. Closure 3: lock plate br (Cat. 324), strap hinge br (Cat. 327), pivot hinge br (Cat. 325). Consumption (culinary) 3: plate gl (Cat. 332), 2 cups tc (Cat. 333–334). Cooking/storage 4: pot tc (Cat. 336), 3 lids tc (Cat. 337–339). Economic 3: 3 coins br (Cat. 326, 328–329). Lighting 1: lamp tc (Cat. 335). Pouring/ablutions 1: patera br (Cat. 322). Storage 2: 2 bottles gl (Cat. 330–331). Unknown function 2: handle br (Cat. 323), vessel tc (Cat. 340).
2nd floor above R19	No finds.
R20 small exedra	See above R19.
R21 exedra	No finds.
R22	No finds.
R23 latrina	Total quantity 2. Architectural: well head/ <i>puteal</i> st (Cat. 341). Unknown function: rounded polished black stone (Cat. 342).
R24 staircase	No finds.

R25 triclinium aestivum	Total quantity 8. Medical/cosmetic: unguent bottle gl (Cat. 348). Storage 7: 3 <i>urcei</i> for garum tc (Cat. 343–344, 348), 2 transport amphorae tc (Cat. 346–347). Storage/culinary consumption 2: plate with olives tc (Cat. 349), bowl with olives tc (Cat. 350).
R26	Total quantity 2. Architectural 2: heap of lime (Cat. 351), column drum st (Cat. 352).
R27	No finds.
R28 fauces	Total quantity 4. Medical/cosmetic 1: strigil br (Cat. 353). Unknown function 3: 3 handles br (Cat. 354–356).
R29 atrium	Total quantity 41 (12 + recess 29). Architectural 1: filter lead (Cat. 361). Closure 4: 3 strap hinges br (Cat. 357, 396–397), lock br (Cat. 360). Consumption (culinary) 2: cup gl (Cat. 363), plate tc/ts (Cat. 364). Fixture 1: nail ir (Cat. 362). Medical/cosmetic 2: 2 unguent bottles gl (Cat. 365, 395). Pouring 2: patera br (Cat. 358), casseruola br (Cat. 359). In the recess 29: Closure 1: lock br (Cat. 389). Economic 23: 23 coins br (Cat. 366–388). Fixture 1: ring br (Cat. 390). Medical/cosmetic 4: 4 unguent bottles gl (Cat. 391–394).
R30 cubiculum	Total quantity 5. Cooking/storage 1: lid tc (Cat. 402). Health/body 2: 2 <i>unguentaria</i> gl (Cat. 398–399). Lighting 1: lamp tc (Cat. 401). Ornament 1: disc gl (Cat. 400=II.4.3).
R31 cella ostiaria	Total quantity 6. Architectural 3: well cover st (Cat. 403), grate ir (window?) (Cat. 406), column drum st (Cat. 408). Closure 1: lock ir (Cat. 407). Tessile work 1: loom weight tc (Cat. 404). Unknown function: ring tc (Cat. 405).
R32 cubiculum	Total quantity 13. Closure 2: lock plate br (Cat. 413); pivot hinge br. (Cat. 415). Fixture 1: ring br (Cat. 414). Furniture 1: fittings (bed?) br (Cat. 412). Medical/cosmetic 6: <i>pyxis</i> br with sulphur (Cat. 410), mirror br (Cat. 411), 4 probes br (Cat. 416–419). Lighting 1: <i>candelabrum</i> top br (Cat. 412). Tessile work 1: needle br (Cat. 420). Unknown function 1: vessel br (Cat. 409).
R33 tablinum	Total quantity 5. Transport 5: carriage fittings br (Cat. 422), 4 wheels ir (Cats. 423–426).
R34 fauces	Total quantity 13. Closure 4: 2 locks br (Cat. 429, 434), 2 pivot hinges br (Cat. 436–437). Fixture: stud br (Cat. 428), 4 nails br (Cat. 430–433), fitting br (Cat. 435). Lighting: lamp br (Cat. 427). Transport: bar ir (Cat. 438).
R41 porticus	No finds.

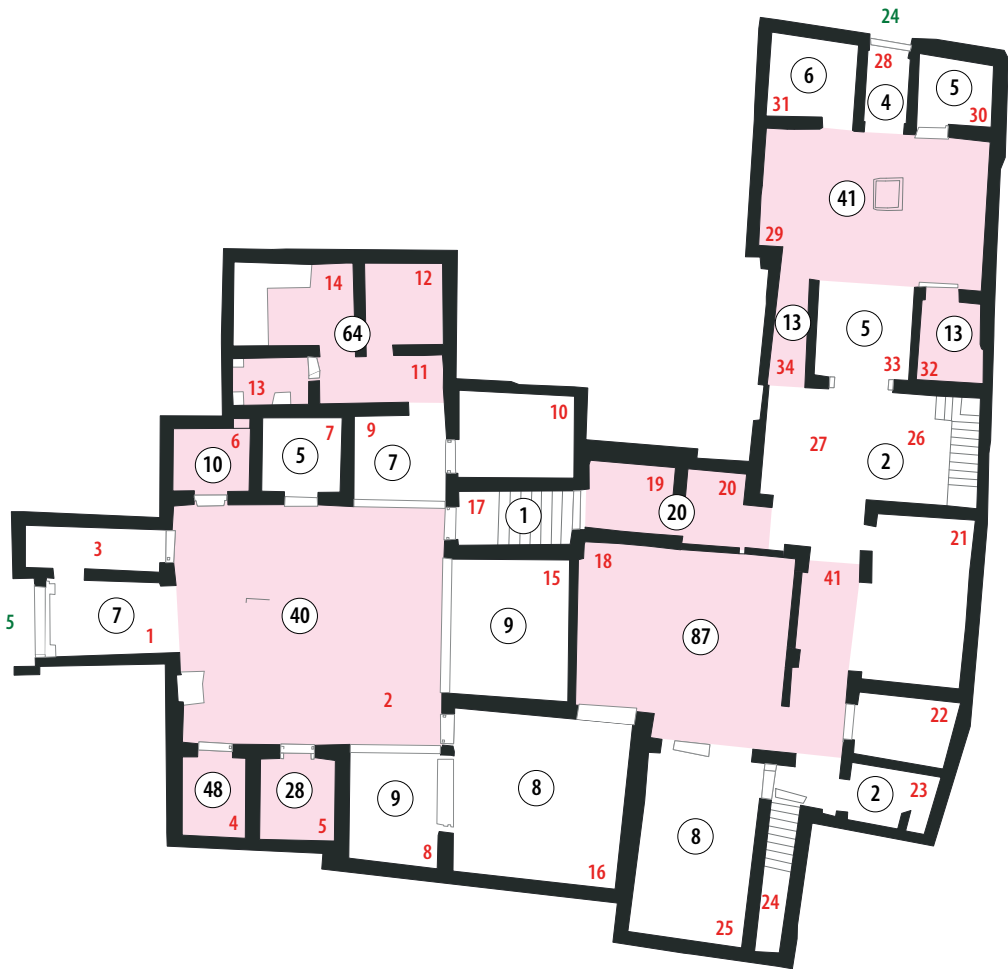

Fig. 1. Find distribution map. Room numbers are in red, and the find numbers inside circles; the rooms with over 10 finds are coloured red.

Appendix 2

SYNTHESIS OF FLOORS AND WALL PAINTINGS

ILKKA KUIVALAINEN, KIRSI MURROS & ANTERO TAMMISTO

This appendix was created to give an idea of the milieu in which the works of art, inscriptions, and other finds were once presented. Thus, the spatial measurements, floor type, decorative elements, and representations of mythological figures in each room are described in context.

Most of the rooms and spaces of the House of Marcus Lucretius were decorated with wall paintings. Several central paintings or details, 26 in total, were removed and transferred to the National Archaeological Museum of Naples (MANN) soon after their discovery. Almost all are well known, but some have lost the information detailing their exact origin over the intervening years. In this Appendix the museum inventory numbers of the paintings are provided when known, and their depictions can be found in *Pompei Pitture e Mosaici* 9 (1999) 141–313. In addition, two formerly unidentified paintings were identified in the course of the EPUH project, and are described and depicted in line drawings here.

The descriptions of the wall paintings are organized in successive zones, starting from the socle (s), followed by the main zone (m) containing the central picture, and then continuing to the left and right outer fields with their secondary figures, after which comes the upper zone (u).

The walls are described in the assumedly most common order of viewing: B = Back wall, R = Right wall, L = Left wall, and D = entrance (“Door”) wall. The points of the compass are conventionally given as S for south, E for east, W for west, and N for north, and b/w indicates black/white.

R1 Fauces N–S 2.2 m, W–E 5.0 cm; 12.0 m²

Floor: Mosaic b/w.

Walls: s: Marble imitation. m: Egyptian blue background. R (S): The central painting: A youth returns from a party, leaning on a female figure playing aulos, a young male attendant with a torch. In the left field, Victoria and a ship’s prow; in the right field Victoria and a cornucopia; in the two yellow vertical divisions (fasciae) a candelabrum and a female figure (a maenad?). L (N): The central painting: Three female figures; the one on the right holds a torch pointed downwards in each hand, on the left a floating maenad and a thyrsus. u: Destroyed.

R2 Atrium N–S 8.35 m, W–E 9.4 m; 78.4 m²*Floor:* Mosaic b/w.*Walls:* s: Marble imitation. m: Egyptian blue background. B (E): Architectural features in perspective, by the opening of tablinum R15. R (S): Scenography probably not unlike the one on the opposite wall. L (N): Scenography with masks and Triton leading hippocampi. D (W): Scenography in the SW and NW corners, and by the doors. u: Destroyed.**R3** Cella ostiaria N–S 1.45 m, W–E 5.15 m; 7.0 m²*Floor:* Cocciopesto.*Walls:* s: Red ochre background. m & u: White background.**R4** Cubiculum N–S 2.8 m, W–E 2.25 m; 6.3 m²*Floor:* Cocciopesto.*Walls:* s: Yellow ochre background, m and u: white background. B (S): In the middle, a sphinx and a suspended tambourine, on the sides a bucranium between masks or gorgoneia. m: The central painting: Cheiron teaches Achilles the lyre. On the left and right side fields an armed Cupid on top of an Ionic capital. u: Light architectural structures, otherwise damaged. In the lunette probably a still life, possibly small birds analogous with the opposite R6. R (W): s: In the middle, a patera and a suspended rhyton, in the intervals Pegasus, on the sides kraters. m: The central painting: Endymion with his dog and Semele. In the left and right fields, an armed Cupid on top of an Ionic capital. u: In the middle, Melpomene, the Muse of Tragedy, and two tragic masks. L (E): s: Analogous with that of R (W) above. m: The central painting: a Nereid riding a hippocamp; in the left and right fields, an armed Cupid on top of an Ionic capital. u: Comic(?) masks, and Thalia, the Muse of Comedy, known only from a drawing. D (N): On both sides, only zones divided by embroidery borders.**R5** Cubiculum N–S 2.85 m, W–E 2.65 m; 7.6 m²*Floor:* Cocciopesto.*Walls:* s: Yellow ochre background, m and u: white background. B (S): s: Middle part destroyed; on the sides, garlands, swans on top of candelabra. m: The central painting: Cyparissus with a stag and a javelin(?); below it (predella), a sea monster and dolphins; on the left side field a satyr, a pedum, and a basket of fruit, and on the right side field a satyr, a basket of fruit, and a rabbit. u: In the middle, a framed landscape; above it, a female with a tambourine; on both sides, Psychae with butterfly wings on top of candelabra; in the lunette, a still life. R (W): s: In the middle, a sphinx and a suspended tambourine; on the sides, globes made of glass on top of candelabra, a suspended krater in between. m: The central painting: a Nereid riding a dolphin; below it (predella), a sea monster (a hippocamp); in the left side field, in a framed red panel, a Psyche and a lion; on the left a Cupid and a bear. u: Middle part destroyed (a framed landscape and a figure?); on both sides a flying Cupid in a pavilion. L (E): s: Identical to the opposite west wall. m: The central painting: Polyphemus with a pedum and the Nereid Galatea; on the left side field; in a framed red panel, a Psyche and a panther on the left, and a Cupid with a crook and a goat on the right. u: In the middle, above a destroyed landscape a female figure with an elephant-scalp headdress, personifying Alexandria or Egypt with a lion; on the sides flying Cupids in pavilions. D (N): On the left-hand side a Cupid with a laurel(?) twig, on the right-hand side a Cupid and a lyre.

R6 Cubiculum N–S 2.2 m, W–E 2.7 m; 6.0 m²

Floor: Cocciopesto.

Walls: s: yellow ochre background, m: white background. B (N): s: A garland with flowers, on the sides sea monsters, and, in between, suspended paterae.

m: The central painting: Pan discovering a sleeping maenad; on the left side, a Cupid with the attributes of Mercurius; on the right side, a Cupid with Dionysiac attributes inside a recess.

u: In the middle part, a small sacral landscape, above which a Victoria, with Cupids on the sides, the one on the right with Apollo's lyre; in the lunette, two sparrows (*Passeriformes Sp.*) in a still life.

R (E): s: Framed panels, a garland with flowers, otherwise destroyed. m: The central painting: Venus with two bathing Cupids in a rocky landscape; on the sides, gilded statues of worshippers of Isis in an architectural frame. u: On the top of the picture, a winged figure, probably Victoria; on the sides, figures carrying votive offerings. L (W): s: In the middle, a garland; other objects now destroyed.

m: The central painting: Narcissus, accompanied by a Cupid, admiring his reflection in a fountain (MANN 9381); on the sides, priestesses of Isis as acroterial figures with paterae and sistra. u: In the middle, a still life with a muraena and a sea-shell. D (S): s: A marine monster on both sides; a flying swan by the door. m: On the left, a Cupid with Apollo's attributes; on the right, another with Herculean attributes.

R7 Cubiculum N–S 2.6 m, W–E 2.8 cm; 7.3 m²

Floor: Cocciopesto.

Walls: s: yellow ochre background, m: white background. B (N): s: A sphinx in the middle, paterae on the sides, and in between a flying swan carrying a ribbon. m: The central painting: Fishing Venus accompanied by Victoria; in the medallions, Mars on the left, Venus with a Cupid on the right. u:

On the top of a scene with a sacral landscape, a statue of Victoria riding a biga; on the sides, Psyche with butterfly wings on top of candelabra; in the lunette, two marine monsters surrounded by pairs of dolphins. R (E): s: Similar to the back wall. m: The central painting: The cyclops Polyphemus receives Galatea's letter from Cupid. u: In the middle, a maenad with a thyrsus and a tambourine, flying on a globe. L (W): s: Similar to back and right-side wall. m: The central painting: Phrixus and Helle (MANN 8896); on the sides, armed Cupids on top of capitals. u: destroyed. D (S): Jupiter and Juno; Cupids on top of candelabra by the door.

R8 Ala N–S 4.0–4.45 m, W–E 3.18 m; 13.2 m²

Floor: Mosaic b/w.

Walls: s: Marble imitation (cipollino). predella: Red side fields, middle white. m: Yellow ochre background. u: White background. B (S): Predella: on both sides, a sea monster with feline head, and dolphins; in the middle, Dionysiac votive offerings. m: The central painting: A poet with his capsula and an actor dressed as a traveller (MANN 9038); in both side fields in the medallions, a flying Psyche and a basket of flowers (MANN 9344 and 9345); u: on the left in an aedicula, a poet (Homer?); in the middle part a framed still-life with two spiny lobsters (*Palinurus vulgaris*) on a shelf; on the right-hand side, in an aedicula, a poetess (Sappho?). R (W): Predella: on both sides, a sea monster with feline head and dolphins; in the middle, Dionysiac votive offerings; m: The central painting: A poet with a comic mask in his lap and a capsula, accompanied by a Muse or a female colleague (MANN 9030); upper part of the field, depicted as viewed behind a hanging curtain, an opening with architectural structures, with twisted columns standing in front of it; in the side fields, in the medallions, on the left a Cupid and Hercules' club (MANN 9341), on the right Psyche and a

floral wreath (MANN 9346); u: on the left a framed landscape, above a male figure (a poet?) reading a scroll, in the middle a floating Victoria in an aedicula, on the right a framed landscape, above a female figure (a listener?). L (E): Only left side field depicted, because of the space taken by the door; predella: a sea monster; m: A Cupid, a pedum, and a rabbit in a medallion (MANN 9343); u: mostly destroyed, part of a framed landscape and architectural structures remain.

R9 Ala N–S 3.25 m, W–E 3.25 cm; 10.4 m²

Floor: Cocciopesto.

Walls: s: Red ochre. m: Yellow ochre background u: White background. B (N): s: In the middle part, a flying eagle and a garland, on the left side a schematic bucranium and ornaments, next to ornamental bands. m: The central painting: Two comic actresses, one holding a pedum and a mask of an old woman and addressing the other taller figure, robed as young female but with a destroyed head; in the predella, on the left, a sea monster; above it, architectural structures in an opening. u: A divinity in the middle, two floating feline beasts; on the left a still-life with two baskets, on the right a destroyed still-life. R(E): s: Ornamental bands. m: Architectural structures with a statue on both sides of the door, in openings above framed predellae. L (W): s: Similar to the back wall. m: The central painting: Medea planning the murder of her children; on both sides, in an opening, a female statue in an architectural setting similar to the left wall.

R10 Cella/storeroom N–S 2.95 m, W–E 4.1 m; 12.1 m²

Floor: Rammed earth.

Walls: Undecorated.

R11 Passage N–S 2.1 m, W–E 4.35 m; 7.2 m². R12 utilitarian N–S 3.3 m, W–E 2.8 m; 7.9 m².

R13 Latrina N–S 1.7 m, W–E 2.75 m; 4.7 m².

R14 Kitchen N–S 3.3 m, W–E 4.3 m; 12.3 m²

Floor: Rammed earth in R11, 12 and 14, tiles in latrina R13.

Walls: Undecorated. In R14 winged phalli, according to the excavation report.

R15 Tablinum N–S 4.8–5.1 m, W–E 4.5 m; 21.8 m²

Floor: Polychrome opus sectile.

Walls: s: Marble imitation (cipollino). m: Background probably cinnabar on yellow ochre ground. u: Destroyed. B (E): s: Cipollino marble imitation under the marble windowsill. R (S): m: Scenography, in the middle of which is an unplastered rectangular area, probably for a wooden picture (the central painting); the side field contains aediculae with two floors. L (N): Similar to the opposite right wall.

R16 Triclinium N–S 5.8 m, W–E 5.8–6.3 m; 35.0 m²

Floor: Mosaic b/w.

Walls: s: Yellow ochre; on the sides and lowest section, a cipollino pattern. m: Cinnabar over a yellow ochre ground. u: Unpainted plaster, probably meant to be hidden by drapery. B (E): s: On black panels, acanthus scrolls on the sides, in the middle a feline, probably attacking a bull; in between the fields on both sides, a sitting maenad leans on a tambourine. m: The central painting (MANN 8992): Drunken Hercules in female attire leaning on Priapos and a thyrsus, accompanied

by Omphale wearing the skin of the Nemean lion and carrying his club, with her entourage; small painting on the left (MANN 9207): an outdoor party by a statue of bearded Dionysus, with a Cupid dancing with an amphora and accompanied by a Cupid playing the kithara; on the right, a small painting (MANN 9193): an outdoor party under a yellow marquee by a statue of Hercules with a Cupid playing aulos, drinking cups of silver on a wooden table in the triclinium. In both of the architectural intervals, a female with long boots standing on Apollo's tripod. R (S): s: Scrolls of acanthus on the left and right, in the middle a lion trying to catch two antelopes; in between, under the intervals, worshippers of Isis depicted as caryatids. m: The central painting (MANN 9285): The triumph of infant Dionysus. The infant in the arms of Silenus touches his thyrsus, in a carriage drawn by two bulls and driven by a young satyr; three maidens lift a cista mystica into the carriage, surrounded by a satyr with goat's legs on the left, and a satyr playing the aulos on the right, followed by a thiasus of maenads; on the left side field a panel (MANN 9191) with Cupids and Psyche preparing for a tragic performance, one playing aulos; on the right side field Cupids and Psyche possibly preparing for a lyrical performance, one holding a kithara (MANN 9206); in the two intervals, openings between the fields, a worshipper of Isis or a maenad on top of a candelabrum, with an aedicula as her background. Frieze: between the m and u, below two windows, two still-lives with fruits. L (N): s: A scroll of acanthus on the left, two dogs pestering a wild boar in the middle, and worshippers of Isis as caryatids in between. m: The central painting: The Indian triumph of Dionysus. Young Dionysus holding a shield erects a tropaeum; he is accompanied by a young satyr holding a thyrsus, Victoria writing on the arms, and a young prisoner sitting on a shield; on the left side field Cupids and Psyche prepare for a tragic performance, next to a table with two masks (MANN 9255). D (W): s: A scroll of acanthus. m: On the left side field a dancing Psyche in the outdoor party of the Cupids and Psyche by the statue of Psyche (MANN 9208).

R17 Fauces/passage with stairs to the upper atrium level N–S 1.9 m, W–E 4.2 m; 7.6 m²

Floor: Cocciopesto.

Walls: s: Black background. m: Red ochre background. u: White background. R (S): m: In the vignettes on the left, a bust of Hercules, with a boar and a club as his attributes; on the right, a bust of Juno, with a peacock as her attribute; in the middle, a candelabrum. u: Architectural features. L (N): In the vignettes on the left, a bust of Jupiter, with his attributes an eagle and globe; on the right, a bust of Venus, with her attribute a vase decorated with dolphins; in the middle, a candelabrum. u: Architectural features.

R18 Viridarium N–S 6.5 m, W–E 7.45–8.0 m; 47.6 m²

Ground: unpaved, garden soil.

Walls: B (E): Red ochre background in the pluteum and lower parts of the two pilasters; tall garden plants painted on white background in the upper parts on the west side of the pilasters.

Fountain: Three painted dolphins in the niche under the ridge, made of scallop shells; above, in the ceiling of the apse, a mosaic of blue, white, and red glass paste tesserae depicting shells; floral candelabra and an acanthus scroll frame the curvy front of the niche. R (S): Destroyed. Garden plants are visible in photos taken in the 1870s. Probably identical with the opposite wall. L (N): Garden painting; lower part on a dark background, half of it is behind a large diagonal lattice fence. Several plants are visible through and above it; the background above is light blue. The graffito *Labyrinthus hic habitat Minotaurus* and a depiction of a labyrinth (*CIL* IV, 2331; see page 00) was cut from the pilaster in the NE corner, above the pluteum wall.

R19 Passage/small exedra N–S 2.4 m, W–E 4.0 m; 7.1 m²

Floor: Cocciopesto.

Walls: s: Red ochre background. m: Yellow ochre background, the upper part turned red ochre through heat. u: Only the frieze is red ochre. B (E): s: A wider left side field, and a narrow middle field depicting plants, previously also on the side field, divided by the painted white base of a column. m: In the vignette on the left, an armed Cupid; the middle part seems to be an architectural opening. R (S): s: In all three fields a plant, in both intervals between the fields, the painted bases of white columns and a patera. m: In the middle there is no painting, because of a window opening onto the garden. The vignette on the left side field is destroyed; an armed Cupid is in the vignette on the right. L (N): s: A plant in all three fields; in the intervals between the column bases, a patera. m: The central painting: Paris and Helen; in the vignettes on both side fields, armed Cupids (thus earlier identified, but now destroyed); intervals depicting architectural openings.

Second floor room above R19

Walls: L (N): s: Red ochre background. m: Red ochre in the middle, yellow ochre on the side fields, white in the intervals between them.

R20 Passage/small exedra N–S 2.55 m, W–E 2.05 m; 6.9 m²

Floor: Cocciopesto.

Walls: (in the recess) s: Yellow ochre background. m: White background. B (N): s: A suspended mask in the middle; embroidery borders. m: The central picture: A still life with writing implements (*instrumentum scriptorium*); the addressee on the sealed letter *M(arco) Lucretio Flam(ini) Martis Decurioni P(ompeis)* (MANN 9818, *CIL* IV, 879; see page 227.); on the sides, openings with architectural structures with candelabra, Fig. 1. R (E): s: Garlands and embroidery borders, a suspended mask. m: A dove sitting on a festoon, hanging from the top of a candelabrum in an architectural setting. L (W): s: Garlands and embroidery borders, a suspended mask. m: A dove sitting on a festoon, hanging from the top of a candelabrum in an architectural setting; Fig. 1. D (window wall S): no figurative decoration, due to a large opening towards the garden.

R21 Exedra (later with a light partition wall: *oecus/triclinium* and *cubiculum*) N–S 6.05 m, W–E 3.45 m; S 12.1 m², N 7.5 m²

Floor: Lavapesta.

Walls: s: Black background. m: Middle yellow, sides red ochre. u: White background. B (E): s: No figures preserved. m: The central painting: Venus depicted with emblems of Mars or Narcissus (MANN, not located); side fields with embroidery borders, a Bacchic head in a medallion at least on the right; in the intervals, architectural structures. u: Only a few spots on the right. R (S): s: No figures preserved. m: The central painting: Apollo and Daphne (MANN 9536); in medallions on both side fields, Bacchic heads; in the intervals, architectural structures. u: Architectural structures. L (N): No decoration.

R22 Cubiculum N–S 2.2–2.35 m, W–E 3.2–3.55 m; 7.8 m²

Floor: Lavapesta.

Walls: s and m: Yellow ochre background. u: White background. B (E): Destroyed. R (S): Destroyed. L (N): m: The central picture destroyed, Cupids in both vignettes on the left and right. u: A figure in an aedicula, supporting festoons on the left and right; embroidery borders.

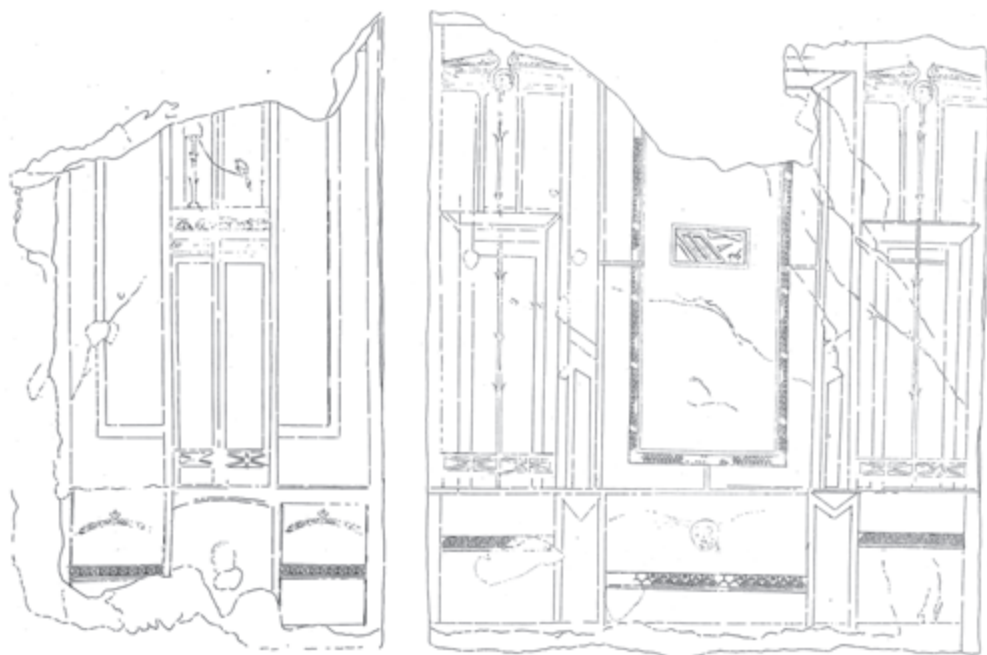

Fig. 1. Room 20 left (W) and back (N) wall. (Drawing by Kirsi Murros.)

R23 Latrina N–S 2.15 m, W–E 2.9–3.2 m; 6.0 m²

Floor: Cocciopesto.

Walls: Wall paintings mostly destroyed; possibly red or yellow ochre in the s, and white in the m and u, at least on the S wall, according to the earlier documentation.

R24 Staircase to the hypogaeum (corridor/cellar) N–S 5.55–5.75 m, W–E 0.95–1.15 m; 5.1 m²

Floor: Tiles.

Walls: No traces of plaster.

R25 Triclinium aestivum N–S 6.4 m, W–E 4.1 m; 26.2 m²

Floor mosaic b/w, centre missing, originally possibly in opus sectile.

Walls: s and m and u: White background. B (S): s: Various divisions, vertical in the middle. m: The predella probably with three Cupids harvesting grapes; detached, three fragments remaining (MANN 9198, 9338, 9340). R (W): s: Architectural features with garlands and ribbons. m: Destroyed, except for the slender columns of the intervals, but according to the miniature model of Pompeii there were floating figures in three fields (Bacchants and genii?) and garlands; on the sides, candelabra; predella probably with playing children (MANN 9103). L (E): s: Vertical divisions. m and u: Mostly destroyed, except on the right side, probably similar to the opposite wall; the destroyed predella painting depicting wild beats may have been on this floor.

R26 together with **R27** N–S 3.9 m, W–E 7.7–8.2 m; R26 12.3 m²

Floor: Lavapesta.

Walls: No decorative elements now preserved. According to Niccolini 1854, 18: s: Yellow background. m: Red background, divided into panels in which marine images such as sea monsters and fruits were depicted (continuing to R41). u: White with vegetal decoration.

R27 together with **R26** N–S 3.9 m, W–E 7.7–8.2 m; R27 16.9 m²

Floor: Lavapesta.

Walls: No decorative elements.

R28 Entrance/fauces N–S 2.4 m, W–E 1.5 m; 3.6 m²

Floor: Cocciopesto.

Walls: s: Black background. m: Possibly white background. Horizontal divisions, a wide band in the middle of the remaining plaster on both the R (E) and L (W) walls. u: Again, vertical divisions with red, and some uncertain decorative elements.

R29 Atrium N–S 5.35 m, W–E 8.5 m; 45.5 m²

Floor: Lavapesta.

Walls: Decorative elements mostly destroyed, but in several areas some remain. s: Black background. Various dividing lines painted with e.g. yellow. m: Red background. Traces of embroidery borders in the side fields, e.g. painted with yellow in the L (W) wall. According to Niccolini 1854, 18: Grotesques on black and red panels, and a central picture with five human figures on the E part of N wall.

R30 Cubiculum N–S 2.2–2.6 m, W–E 2.7 m; 6.0 m²

Floor: Cocciopesto.

Features: A small window opening to the street.

Walls: Various dividing lines, but no other decorative elements remain. According to Niccolini 1854, 18: s: Yellow/black background. m: Yellow ochre background divided with candelabra. Six busts inside medallions and two flying Cupids, a lost central painting. u: White background, animals above a stucco frieze (two deers and two panthers).

R31 Cella ostiaria N–S 2.65–3.15 m, W–E 3.15 m; 8.6 m²

Floor: Cocciopesto.

Features: Originally, a window opening to the street (now blocked).

Walls: s: Black background. m: Possibly white background with some red lines, according to Niccolini 1854, 18, also green lines. No other decorative elements.

R32 Cubiculum N–S 2.9 m, W–E 2.1–2.25 m; 6.1 m²

Floor: Lavapesta with marble inserts.

Walls: s: Yellow/black background. m: Yellow ochre background. u: White background. Various dividing lines and a candelabrum with vertical lines in the u of the B (S) wall, vertical division in the u of the D (N) wall. No other decorative elements remain. According to Niccolini 1854, 18, some grotesques.

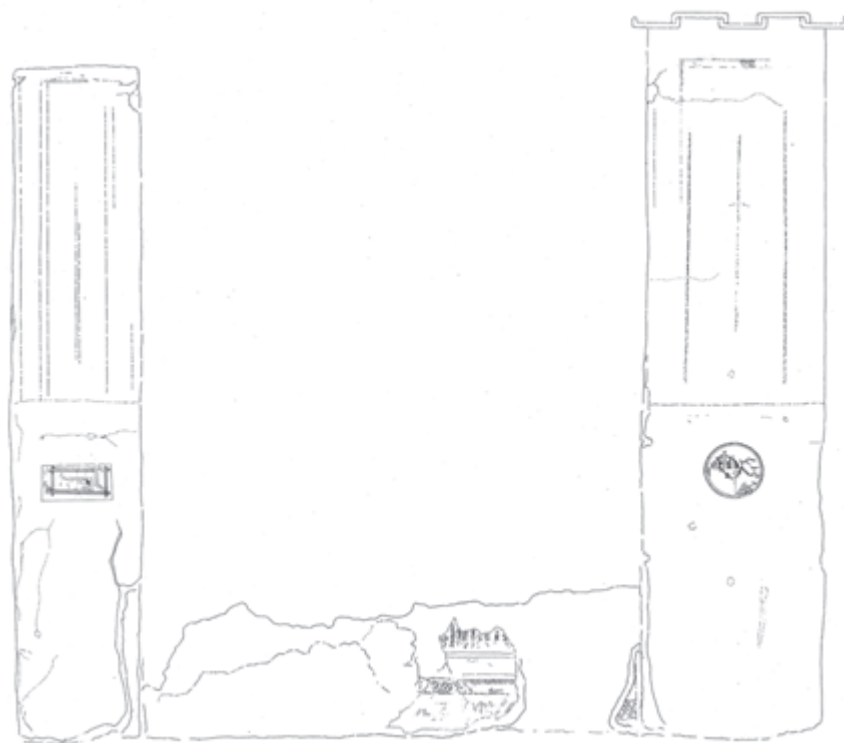

Fig. 2. Room 41 right (W) wall. (Drawing by Kirsi Murros.)

R33 Tablinum N–S 3.28 m, W–E 3.35 m; 11.2 m²

Floor: Lavapesta.

Walls: s: Black background. m: Red ochre background, probably with yellow intervals in the middle, black edges. According to Niccolini 1854, 18: Three panels with grotesques such as flying Cupids, the first carrying fruits, the second a vase and a thyrsus, and the third a lyre. u: Possibly white, but almost completely destroyed. Various dividing lines in the m, probably forming embroidery borders in all four wider fields, and some divisions in the intervals, but no other decorative elements remain. There may have been also candelabra.

R34 Corridor/fauces N–S 3.8 m, W–E 1.15–1.3 m; 4.6 m²

Floor: Lavapesta with marble inserts.

Walls: No decorative elements.

R41 Porticus N–S 11.1 m, W–E 1.55–4.4 m; 24.1 m²

Floor: Lavapesta.

Walls: R (W): Red ochre background in the pluteum and lower parts of the two pilasters, upper parts are white. On the pluteum wall towards the east there is a garden painting with a yellow trellis

on the left, quite low in the painting, and another lattice fence in the middle that is higher in the painting, and behind it garden plants; in the middle there used to be wrestlers pointing towards the palaestra and its fountain, by which there were two white birds, probably herons (*Egretta sp.*); all of these are now destroyed. On the southern pilaster there was a rectangular still-life painting (MANN inv. San Giorgio 1678; Fig. 2), depicting a framed panel with doors, inside of which was various comestibles. On the northern pilaster towards east there was a circular still-life painting (MANN 8642; Fig. 2) on a red ochre background, depicting figs, a plucked chicken, and grapes. This location has been falsely reported as having a graffito instead of this painting. On the northern pilaster towards the north was a large cantharus on a white background; on the other five sides of the upper parts of the pilasters, on a white background, candelabra and/or several vertical lines with yellow and blue. L (E): s: Yellow ochre background. m: Framed still-lives or sea monsters on red ochre background. u: Architectural features on white background.



Fig. 3. Domus Pompeiana exhibition in Amos Anderson Art Museum.

Appendix 3

PLAN OF THE HOUSE OF MARCUS LUCRETIUS IX 3, 5.24



ILLUSTRATION CREDITS

Front cover

Watercolour by Edward Falkener in 1847. ©Michael Portman.

'Preface'

P. 8: Helen Väänänen. Institutum Classicum, University of Helsinki.

'Introduction to the Project'

P. 13: Maija Holappa (EPUH).

'Abitanti e visitatori'

Fig. 6, 8: EPUH.

Figs. 1–4, 7, 9, 10: Antonio Varone. ©Parco archeologico di Pompei.

Fig. 5: Tiina Tuukkanen (EPUH). ©Parco archeologico di Pompei.

'Schede epigrafiche'

Figs. 1–3: ©MANN.

Fig. 4, 7: Antonio Varone. ©Parco archeologico di Pompei;

Fig. 5, 8, 11, 13, 15: ©Parco archeologico di Pompei.

Fig. 12: Tiina Tuukkanen (EPUH). ©Parco archeologico di Pompei.

Fig. 6, 9, 10, 14, 16: ©Parco archeologico di Pompei.

'Documentation History'

Fig. 1: Alma-Tadema's collection, XAT, Portfolio 11, 7986. Cadbury Research Library: Special Collections, University of Birmingham.

Fig. 2: Drawing by Carl Christian Vogel von Vogelstein in 1847. Kupferstich-Kabinett, Staatliche Kunstsammlungen Dresden. Photo: Andreas Diesend.

Fig. 3: Falkener 1852, 34–35.

Figs. 4–5: Giuseppe Abbate's illustration in Niccolini 1854, pl. I & IV.

Fig. 6: Breton 1870, 241.

'Marble Sculpture'

Fig. 1: *Real Museo Borbonico* 14 (1852). Heidelberg University Library, C2422: 14 1852, Frontispiece.

Fig. 2: Edward Falkener's drawing. ©Michael Portman.

Fig. 3: Overbeck – Mau 1884, 314.

Fig. 4, 15: Breton 1870, 388, 394.

Fig. 5, 28, 40: Robert Rive's photo ca. 1859. Joseph Armstrong Baird collection of nineteenth century architectural photographs, box 37, Getty Research Institute, Los Angeles (88.R.8).

Fig. 6: Dwyer 1982, 41, fig. 1.

Figs. 7–13, 18–19, 21–23, 25, 27, 31–38 41–43, 45–49, 51–55, 57. Heikki Häyhä, Mika Seppälä (EVTEK); Tiina Tuukkanen, Matti Mustonen, Ilkka Kuivalainen, Antero Tammisto, Eeva-Maria Viitanen (EPUH). ©Parco archeologico di Pompei.

Fig. 14, 29, 39: Niccolini 1854, pl. I.

Fig. 16: Warscher 1948. Halsted B. Vander Poel Campanian collection, Getty Research Institute, Los Angeles (2002.M 16).

Fig. 17: photo no. A177. ©Parco Archeologico di Pompei.

Fig. 20: Falkener 1852, 76.

Fig. 24, 26, 30: Alma-Tadema's collection, XAT, Portfolio 11, 7986, Cadbury Research Library: Special Collections, University of Birmingham.

Fig. 44: Ria Berg (EPUH). ©MANN.

Fig. 50: ©MANN.

Fig. 56: Giorgio Sommer.

P. 116: Alma-Tadema's Collection XAT, Portfolio 11, no. 7987. Cadbury Research Library: Special Collections, University of Birmingham.

'Minor Arts of Terracotta'

Figs. 1–6b, 7–10. ©MANN.

Figs. 6c–d: Antikensammlung, Staatliche Museen zu Berlin -Preussischer Kulturbesitz-.

Photo: Johannes Laurentius.

'Vessels'

Fig. 1, 3, 7, 8, 11, 13, 18, 21, 23, 26, 28, 31, 32, 34, 38: Ria Berg.

Figs. 4, 29: Giovanni Abbate in Niccolini 1854.

Figs. 15–17 from Scatozza Höricht 1986.

Fig. 36: Edward Falkener.

Fig. 37: *CIL* IV.

Fig. 2, 5–6, 12, 14, 19, 20, 22, 24, 25, 30, 33, 35, 39: Ria Berg. ©MANN.

Fig. 10: Antero Tammisto (EPUH). ©MANN.

Fig. 9: Anna Rocco. ©MANN.

'Instruments'

Fig. 2, 48: Giuseppe Abbate in Niccolini 1854.

Fig. 3, 7, 9, 14, 16, 18, 20, 22, 24, 26, 28, 30, 40–42, 44, 47, 51, 53: Ria Berg.

Fig. 10: Benedetto Vulpes 1847.

Fig. 11, 12, 33, 35: Carlo Ceci 1858.

Figs. 31–32, 49: from Allison 2006/Maiuri 1933; Fig. 32: Allison 2006/Maiuri 1933/M. Varchetta.

Fig. 34: Allison 2006/Maiuri 1933 e S. Cann.

Fig. 1: Gianluca Mandatori. ©MANN.

Fig. 4, 6, 8, 13, 15, 17, 19, 21, 23, 25, 27, 29, 37–39, 43, 45, 46, 50, 52: Ria Berg (EPUH). ©MANN.

'Fixtures'

Fig. 1, 2, 4, 5: Carlo Ceci 1858.

Fig. 3: Allison 2006/M. Varchetta.

'Architectural Elements'

Fig. 1: Ria Berg (EPUH). ©MANN.

'Wall Plaster Fragments'

Fig. 1: Tiina Tuukkanen, Ville Hakanen (EPUH).

Figs. 2–11: Heikki Häyhä, Mika Seppälä (EVTEK); Tiina Tuukkanen, Matti Mustonen, Antero Tammisto (EPUH). ©Parco archeologico di Pompei.

Plates: Maija Holappa (EPUH).

'Masks'

Figs. 1–2: EPUH.

'Conclusions'

P. 227: Painted letter with the name of M. Lucretius. Falkener 1852, 72.

'Appendix 2'

Fig. 1: Distribution map of the finds in the House of Marcus Lucretius. Ria Berg, Maija Holappa (EPUH).

'Appendix 2'

Figs. 1–2: Kirsi Murros (EPUH).

Fig. 3: Domus Pompeiana exhibition in Amos Anderson Art Museum. Mika Seppälä (EVTEK).

'Appendix 3'

Plan of the House of Marcus Lucretius. Maija Holappa (EPUH).

BIBLIOGRAPHY

- Adam 1986 = J.P. Adam, 'Observations techniques sur les suites du séisme de 62 à Pompéi', in C. Albore Livadie (ed.), *Tremblements de terre, éruptions volcaniques et vie des hommes dans la Campanie antique*, Naples 1986, 67–89.
- Agnati 1999 = U. Agnati, *Per la storia romana della provincia di Pesaro e Urbino*, Rome 1999.
- Allison 1997 = P. Allison, 'Artefact Distribution and Spatial Function in Pompeian Houses', in B. Rawson – P. Weaver (eds.), *The Roman Family in Italy. Status, Sentiment, Space*, Oxford 1997, 321–354.
- Allison 2004 = P. Allison, *Pompeian Households. An Analysis of the Material Culture*, Los Angeles 2004.
- Allison 2006 = P. Allison, *The Insula of The Menander at Pompeii III: The Finds, a Contextual Study*, London 2006. With *Pompeian Households: An On-line Companion*, <http://www.stoa.org/projects/ph/home>.
- Amoroso 2007 = A. Amoroso, *L'Insula VII, 10 di Pompei. Analisi stratigrafica e proposte di ricostruzione*, Rome 2007.
- Anderson 2011 = M. Anderson, 'Disruption or Continuity? The Spatio-Visual Evidence of Post-Earthquake Pompeii', in E. Poehler, M. Flohr & K. Cole (eds.), *Pompeii. Art, Industry and Infrastructure*, Oxford 2011, 7–87.
- Appleton 1987 = G. Appleton, *Animal Sculpture from Roman Gardens Buried by Vesuvius*, Diss. Newcastle upon Tyne 1987.
- Avellino 1848 = F. Avellino, 'Descrizione degli scavi di Pompei ne' primi dieci mesi dell'anno 1847', *BullArchNap* 89, 90, 93 (1848) 1–8, 9–13, 33–37.
- Avisseau-Broustet – Colonna – Lapatin 2014 = M. Avisseau-Broustet, C. Colonna & K. Lapatin, 'The Berthouville Treasure: A Discovery "As Marvelous as It Was Unexpected"', in Lapatin 2014.
- Bacchetta 2006 = A. Bacchetta, *Oscilla. Rilievi sospesi di età romana (Il Filarete 243)*, Milan 2006.
- Bailey 2008 = D.M. Bailey, *Catalogue of Terracottas in the British Museum 4. Ptolemaic and Roman Terracottas from Egypt*, London 2008.
- Baratta 2018 = G. Baratta, 'Le rappresentazioni di *instrumenta scriptoria* e di *instrumentum inscriptum* negli affreschi della Villa. Studio preliminare', in F. Costabile, 'L'archetipo di formula processuale dell'Editto «*Iudex esto. Si parret...*»: l'invenzione di Mucio Scevola delle azioni con *intentio certa*. La scoperta degli affreschi della 'Villa del Giurista' sull'Aniene a Roma', *MEP* 21:23 (2018), 26–38.
- Bartman 1992 = E. Bartman, *Ancient Sculptural Copies in Miniature*, Leiden – New York – Cologne 1992.
- Bassani 2008 = M. Bassani, *Sacraria. Ambienti e piccoli edifici per il culto domestico in area vesuviana (Antenor Quaderni 9)*, Rome 2008.
- Bayardi 1755 = O.A. Bayardi, *Catalogo degli antichi monumenti dissotterrati dalla scoperta città di Ercolano*, Naples 1755.
- Bechi 1852 = G. Bechi, 'Relazione degli scavi di Pompei. Da Agosto 1842 a Gennaio 1852', *MB* 14 (1852) 1–23.
- Benefiel 2010 = R. Benefiel, 'Rome in Pompeii: Wall Inscriptions and GI', in F. Feraudi-Gruénais (ed.), *Latin on Stone: Epigraphic Research and Electronic Archives*, Lanham 2010.

- Beretta – Di Pasquale 2004 = M. Beretta – G. Di Pasquale (eds.), *Vitrum. Il vetro fra arte e scienza nel mondo romano*, Milan 2004.
- Berg 2008a = R. Berg, 'Mobili e arredi della casa romana', in *Domus Pompeiana*, 104–125.
- Berg 2008b = R. Berg, '2003-2006 ritrovamenti archeologici', in *Domus Pompeiana*, 151–163.
- Berg 2010 = R. Berg, *Il mundus muliebris nelle fonti latine e nei contesti pompeiani*, Diss. Helsinki 2010.
- Berg 2014 = R. Berg, 'La casa come cassaforte. Riflessioni sulle zone di attività e zone di deposito nelle case pompeiane', in J.M. Álvarez Martínez, T. Nogales Basarrate & I. Rodà de Llanza (eds.), *Centre and Periphery in the Ancient World* (Proceedings of the XVIIIth International Congress of Classical Archaeology 2, Mérida 2013), Mérida 2014, 1029–1032.
- Berg 2015 = R. Berg, 'Bathing the Infirm. Bronze Basins in Pompeian Houses', in C. Krötzl, K. Mustakallio & J. Kuuliala (eds.), *Infirmity in Antiquity and the Middle Ages. Social and Cultural Approaches to Health, Weakness and Care*, Surrey – Burlington 2015, 201–221.
- Berg 2016 = R. Berg, 'Dominae apothecarum. Gendering Storage Patterns in Roman Houses', in R. Berg (ed.), *The Material Sides of Marriage. Women and Domestic Economies in Antiquity* (Acta IRF 43), Rome 2016, 175–189.
- Berg 2017 = R. Berg, 'Attrarre. Charis, kosmesis e il mondo della bellezza', in M. Osanna – C. Rescigno (eds.), *Pompei e i greci*, Milan 2017, 213–220.
- Berg et al. 2008 = R. Berg, I. Kuivalainen, L. Pietilä-Castrén, A. Tammisto & E.-M. Viitanen, 'Catalogo', in *Domus Pompeiana*, 205–211.
- Bergmann 2007 = B. Bergmann, 'Seeing Women in the Villa of the Mysteries. A Modern Excavation of the Dionysiac Murals', in V.C. Gardner Coates – J.L. Seydl (eds.), *Antiquity Recovered. The Legacy of Pompeii and Herculaneum*, Los Angeles 2007, 231–270.
- Bernabò Brea 2001 = L. Bernabò Brea, with the collaboration of M. Cavalier, *Maschere e personaggi del teatro greco nelle terracotte liparesi*, Rome 2001.
- Bernabò Brea 2002 = L. Bernabò Brea, with the collaboration of M. Cavalier, *Terracotte teatrali e buffonesche della Sicilia orientale e centrale*, Palermo 2002.
- Berry 1997a = J. Berry, 'Household Artefacts: Re-interpreting Roman Domestic Space', in R. Laurence – A. Wallace-Hadrill (eds.), *Domestic Space in the Roman World: Pompeii and Beyond* (JRA Suppl. 22), Portsmouth 1997, 183–195.
- Berry 1997b = J. Berry, 'The Conditions of Domestic Life in Pompeii in AD 79: A Case-Study of Houses 11 and 12, Insula 9, Region I', *PBSR* 65 (1997) 103–125.
- Berry 1997c = J.T. Berry, *The Roman House at Work*. Diss. Reading 1997.
- Berry 2007 = J. Berry, 'Instrumentum domesticum. A Case Study', in J.J. Dobbins – P.W. Foss (eds.), *The World of Pompeii*, London – New York 2007, 292–301.
- Besques 1986 = S. Besques, *Musée national du Louvre. Catalogue raisonné des figurines et reliefs en terre-cuite grecs, étrusques et romains* 4,1. Époques hellénistique et romaine. Italie méridionale, Sicile, Sardaigne, Paris 1986.
- Beyen 1938 = H.G. Beyen, *Die pompejanische Wanddekoration vom zweiten bis zum vierten Stil* 1, The Hague 1938.
- Beyen 1960 = H.G. Beyen, *Die pompejanische Wanddekoration vom zweiten bis zum vierten Stil* 2, The Hague 1960.
- Bieber 1961 = M. Bieber, *The Sculpture of the Hellenistic Age* (rev. ed.), New York 1961.
- Bisi Ingrassia 1977 = A.M. Bisi Ingrassia, 'Le lucerne fittili dei nuovi scavi di Ercolano', in *L'instrumentum domesticum di Ercolano e Pompei nella prima età imperiale* (Quaderni di cultu-

- ra materiale 1), *Rome 1977*, 73–104.
- Bliquez 1994 = L.J. Bliquez, *Roman Surgical Instruments and Other Minor Objects in the National Archaeological Museum of Naples*, Mainz 1994.
- Blümner 1912 = H. Blümner, *Technologie und Terminologie der Gewerbe und Künste bei Griechen und Römern* 1, Berlin 1912².
- Boesterd 1956 = M.H.P. den Boesterd, *The Bronze Vessels in the Rijksmuseum G.M. Kam at Nijmegen*, Nijmegen 1956.
- Borgongino – Stefani 2015 = M. Borgongino – G. Stefani, ‘L’agricoltura nell’area vesuviana’, in *Nutrire l’impero*, 93–106.
- Borriello 1999 = M. Borriello, ‘Il legno e le sue lavorazioni’, in *Homo faber*, 121–130.
- Boube Piccot 1975 = C. Boube Piccot, *Les bronzes antiques du Maroc 2. Le mobiliér*, Rabat 1975.
- Bowes 2015 = K. Bowes, ‘At Home’, in R. Raja – J. Rüpke (eds.), *A Companion to the Archaeology of Religion in the Ancient World*, Hoboken NJ 2015, 209–219.
- Boyce 1937 = G.K. Boyce, *Corpus of the Lararia of Pompeii (MAAR 14)*, Rome 1937.
- Breglia 1941 = L. Breglia, *Catalogo delle oreficerie del Museo Nazionale di Napoli*, Rome 1941.
- Breton 1855 = E. Breton, *Pompeia. Décrite et dessinée*, Paris 1855.
- Breton 1870 = E. Breton, *Pompeia. Décrite et dessinée, troisième édition revue et considérablement augmentée*, Paris 1870.
- Bruno – Scott 1993 = V.J. Bruno – R.T. Scott, *Cosa 4: The Houses*, Ann Arbor – Rome 1993.
- Butler 1886 = W. Butler, *Pompeii Descriptive and Picturesque*, Edinburgh – London 1886.
- Cahill 2010 = N. Cahill, ‘Functional Analyses of Ancient House Inventories’, in S. Ladstätter – V. Scheibelreiter (eds.), *Städtisches Wohnen im östlichen Mittelmeerraum. 4. Jh. v. Chr. – 1. Jh. n. Chr.* (Arch. Forsch. 18), Wien 2010, 477–495.
- Cain 1988 = H.-U. Cain, ‘Chronologie, Ikonographie und Bedeutung der römischen Maskenreliefs’, *BJ* 188 (1988) 107–221.
- Cappelletto et al. 2013 = E. Cappelletto, D. Bernal Casasola, D. Cottica, M. Bustamante Alvarez, M. Lara Medina & A.M. Sáez Romero, ‘Urcei per salse di pesce da Pompei-Ercolano: una prima analisi’, in *Actas del I congreso internacional de la SECAH*, Cádiz 2011 (Monografías ex officina Hispana 1:2), Cádiz 2013, 271–280.
- Caputo – Tamburrelli 2007 = T. Caputo – V. Tamburrelli, ‘Lucerne fittili del Museo archeologico di Napoli da Pompei. Regioni, I, V, VI, VII, VIII, IX’, *RST* 18 (2007) 67–80.
- Carcopino 1960 = J. Carcopino, ‘Un procureur méconnu de Néron’, *BSAF* 1960, 150–158.
- Carrella 2008 = A. Carrella, ‘Sezione B – Regioni V-VI’, in *Marmora pompeiana*, 63–108.
- Castiglione Morelli del Franco 1983 = N. Castiglione Morelli del Franco, ‘Le lucerne della Casa di Giulio Polibio a Pompei’, in *Pompeii, Herculaneum, Stabiae. Bollettino dell’Associazione Internazionale Amici di Pompei* 1 (1983) 213–258.
- Castiglione Morelli 1996 = V. Castiglione Morelli, ‘La ceramica comune nell’*instrumentum domesticum* della casa di C. Giulio Polibio a Pompei’, in *Les céramiques communes de Campanie et de Narbonnaise (Ier s. av. J.-C. – IIe s. ap. J.-C.): la vaisselle de cuisine et de table* (Actes des journées d’étude organisées par le Centre Jean Bérard et la Soprintendenza Archeologica per le Province di Napoli e Caserta, Naples, 27–28 mai 1994), Naples 1996, 105–112.
- Castiglione Morelli del Franco – Vitale 1989 = V. Castiglione Morelli del Franco – R. Vitale, ‘L’insula 8 della Regio 1: un campione d’indagine socio-economica’, *RSP* 3 (1989) 185–221.
- Castrén 1983 = P. Castrén, *Ordo populusque Pompeianus. Polity and Society in Roman Pompeii* (Acta IRF 8), Rome 1975, 1983².

- Castrén 2008 = P. Castrén, 'Notizie su Marco Lucrezio', in *Domus Pompeiana*, 26–29.
- Castrén – Berg – Tammisto – Viitanen 2008 = P. Castrén, R. Berg, A. Tammisto & E.-M. Viitanen, 'In the Heart of Pompeii. Archaeological Studies in the Casa di Marco Lucrezio (IX, 3, 5.24)', in P.G. Guzzo – M. P. Guidobaldi (eds.), *Nuove ricerche archeologiche nell'area Vesuviana (scavi 2003–2006)*, (Studi della soprintendenza archeologica di Pompei 25), Rome 2008, 331–340.
- Castrén – Fiema – Viitanen 2005 = P. Castrén, Z.T. Fiema & E.-M. Viitanen, 'Expeditio Pompeiana Universitatis Helsingiensis: The 2002 Fieldwork Season', in P.G. Guzzo – M. P. Guidobaldi (eds.), *Nuove ricerche archeologiche a Pompei ed Ercolano* (Studi della Soprintendenza archeologica di Pompei 10), Rome 2005, 367–370.
- Ceci 1858 = C. Ceci, *Piccoli Bronzi del Real Museo Borbonico*, Naples 1858.
- Cheilik 1963 = S.M. Cheilik, 'A Roman Terracotta Savings Bank', *AJA* 67 (1963) 70–71.
- Chiavia 2002 = C. Chiavia, *Programmata. Manifesti elettorali nella colonia romana di Pompei*, Turin 2002.
- Ciancio Rossetto 1973 = P. Ciancio Rossetto, *Il sepolcro del fornaio Marco Virgilio Eurisace a Porta Maggiore*, (I monumenti romani 5), Rome 1973.
- Cleopatra* = G. Gentili (ed.), *Cleopatra. Roma e l'incantesimo dell'Egitto*, Milan 2013.
- Collezioni Napoli* = M. Borriello, M. Lista, U. Pappalardo, V. Sampaolo & C. Ziviello, *Le collezioni del Museo nazionale di Napoli I, I mosaici, le pitture, gli oggetti di uso quotidiano, gli argenti, le terrecotte invetriate, i vetri, i cristalli, gli avori*, Rome 1986.
- Conspectus* = E. Ertlanger et al. (eds.), *Conspectus formarum terrae sigillatae Italico modo confectae*, Bonn 1990.
- Conticello De' Spagnolis – De Carolis 1988 = M. Conticello De' Spagnolis – E. De Carolis, *Le lucerne di bronzo di Ercolano e Pompei* (Soprintendenza archeologica di Pompei. Cataloghi 2), Rome 1988.
- Cool 2016 = H.E.M. Cool, *The Small Finds and Vessel Glass from Insula VI.1 Pompeii: Excavations 1995–2006*, Oxford 2016.
- Cool (forthcoming) = H.E.M. Cool, 'The vessel glass', in M. Fulford, A. Clarke, E. Durham & N. Pankhurst (eds.), *Silchester Roman Town: The Insula IX Town Life Project, vol. 4*, (Britannia Monograph 33), London, forthcoming.
- Cooley – Cooley, *Sourcebook* = A.E. Cooley – M.G.L. Cooley (eds.), *Pompeii. A Sourcebook*, London 2004.
- Coralini 2018 = A. Coralini (ed.), *Pompeii. Insula IX 8. Vecchi e nuovi scavi (1879–)*, Bologna 2018.
- Corti 2001 = C. Corti, 'Misure di capacità', in C. Corti – N. Giordani (eds.), *Pondera. Pesi e misure nell'antichità*, Campogalliano 2001, 219–225.
- Cova 2013 = E. Cova, 'Cupboards, Closets, and Shelves: Storage in the Pompeian House', *Phoenix* 67 (2013) 373–391.
- Cullin-Mingaud 2010 = M. Cullin-Mingaud, *La vannerie dans l'antiquité romaine. Les ateliers de vanniers et les vanneries de Pompéi, Herculaneum et Oplontis* (Collection du Centre Jean Bérard 35), Naples 2010.
- Curtis 1984–1986 = R.I. Curtis 'Product Identification and Advertising on Roman Commercial Amphorae', *AncSoc* 15–17 (1984–1986) 209–228.
- D'Acunto 2008 = L.A. D'Acunto, 'Sezione D – Regio IX', in *Marmora pompeiana*, 155–203.
- Dall'Olio 2016 = C. Dall'Olio, 'Robert Rive, un fotografo tedesco a Napoli', in C. Dall'Olio (ed.), *Robert Rive. Photographies d'Italie*, Modena 2016, 11–17.

- d'Ambrosio – Borriello 1990 = A. d'Ambrosio – M. Borriello, *Le terrecotte figurate di Pompei* (Soprintendenza archeologica di Pompei, Cataloghi 4), Rome 1990.
- d'Ambrosio – De Carolis 1997 = A. d'Ambrosio – E. De Carolis, *I monili dall'area vesuviana*, Rome 1997.
- d'Ambrosio – De Carolis – Guzzo 2003 = A. d'Ambrosio, E. De Carolis & P.G. Guzzo, 'I contesti di oggetti trovati presso le vittime', in *Storie da un'eruzione*, 73–83.
- Daremberg – Saglio = C. Daremberg – E. Saglio, *Dictionnaire des antiquités grecques et romaines*, Paris 1873–1919.
- De Caro 1983 = S. De Caro, 'Boscoreale', in *Pompeii, Herculaneum, Stabiae. Bollettino dell'Associazione Internazionale Amici di Pompei* 1 (1983) 328–331.
- De Caro 2001 = S. De Caro, *La natura morta nelle pitture e nei mosaici delle città vesuviane*, Naples 2001.
- De Carolis 1999 = E. De Carolis, 'Lanterna', in *Homo faber*, 260.
- De Carolis 2003a = E. De Carolis, 'Sistemi di illuminazione', in G. Stefani (ed.), *Menander. La casa del Menandro a Pompei*, Milan 2003, 132–141.
- De Carolis 2003b = E. De Carolis, 'La Grande Palestra (II, 7)', in *Storie da un'eruzione*, 377–385.
- De Carolis 2004 = E. De Carolis, 'Il vetro nella vita quotidiana', in Beretta – Di Pasquale, 71–79.
- De Carolis 2007 = E. De Carolis, in G. Di Pasquale – F. Paolucci (eds.), *Il giardino antico da Babilonia a Roma. Scienza, arte e natura*, Leghorn 2007, 142–153.
- De Carolis 2013 = E. De Carolis, *Robert Rive: un album fotografico di Pompei* (Quaderni di Studi Pompeiani 6), Pompeii 2013.
- De Carolis – Patricelli – Ciarallo 1998 = E. De Carolis, G. Patricelli & A. Ciarallo, 'Rinvenimenti di corpi umani nell'area urbana di Pompei', *RSP* 9 (1998) 190–191.
- Della Corte 1965 = M. Della Corte, *Case ed abitanti di Pompei*, Naples 1914–1925, (P. Soprano, ed.) 1965³.
- Deppmeyer 2011 = K. Deppmeyer, 'Innenarchitektur und Möblierung eines römischen Hauses', in *Pompeji, Nola, Herculaneum*, 225–236.
- De Tommaso 1990 = G. De Tommaso, *Ampullae vitreae. Contenitori in vetro di unguenti e sostanze aromatiche dell'Italia romana (I sec. a.C. – III sec. d.C.)*, Rome 1990.
- De Vos 1981 = M. De Vos, 'La bottega di pittori di Via di Castricio', in I. Bragantini, F. Parise Badoni & M. De Vos (eds.), *Pompeii 1748–1980. I tempi della documentazione*, Rome 1981, 119–130.
- Dickmann 2011 = J.-A. Dickmann, 'Die Casa del Menandro und ihre Nachbarn', in *Pompeji, Nola, Herculaneum*, 206–214.
- Dicus 2014 = K. Dicus, 'Resurrecting Refuse at Pompeii. The Use-Value of Urban Refuse and its Implications for Interpreting Archaeological Assemblages', in H. Platts et al. (eds.), *TRAC 2013. Proceedings of the Twenty-Third Annual Theoretical Roman Archaeology Conference*, Oxford – Philadelphia 2014, 65–78.
- Diehl 1930 = E. Diehl, *Pompeianische Wandinschriften und Verwandtes*, Berlin 1930².
- Di Gioia 2006 = E. Di Gioia, *La ceramica invetriata in area vesuviana* (Studi della Soprintendenza archeologica di Pompei 19), Rome 2006.
- Dodero 2009 = E. Dodero, 'Statuette di pantera', in C. Gasparri (ed.), *La collezione Farnese*, Naples 2009, 68–69.
- Döhl 1976 = H. Döhl, *Plastik aus Pompeji. I Katalog, II Bemerkungen zum Katalog* (Habilitationsschrift), Göttingen 1976.

- Domus Pompeiana* = P. Castrén (ed.), *Domus Pompeiana. Una casa a Pompei*, Helsinki 2008.
- Domus – viridaria – horti picti* = *Domus, viridaria, horti picti* (Soprintendenza archeologica di Pompei, Le mostre 15), Naples 1992.
- Drummond – Nelson 1994 = S.K. Drummond – L.H. Nelson, *Roman Imperial Frontier in the West*, London – New York 2015.
- Dunbabin 1993 = K. Dunbabin, ‘Wine and Water at the Roman «convivium»’, *JRA* 6 (1993) 116–141.
- Dunbabin 1995 = K. Dunbabin, ‘Houses and Households in Pompeii’, *JRA* 8 (1995) 387–390.
- Dwyer 1981 = E.J. Dwyer, ‘Pompeian Oscilla Collections’, *MDAI(R)* 88 (1981) 247–306.
- Dwyer 1982 = E.J. Dwyer, *Pompeian Domestic Sculpture. A Study of Five Pompeian Houses and Their Contents* (Archaeologica 28), Rome 1982.
- Dwyer 1991 = E. Dwyer, ‘The Pompeian Atrium House in Theory and in Practice’, in E.K. Gazda (ed.), *Roman Art in the Private Sphere. New Perspectives on the Architecture and Decor of the Domus, Villa, and Insula*, Ann Arbor 1991, 25–48.
- Dyer 1867 = T.H. Dyer, *The ruins of Pompeii. A series of eighteen photographic views, with an account of the destruction of the city, and a description of the most interesting remains*, London 1867.
- Dyer 1875 = T.H. Dyer, *Pompeii. Its History, Buildings, and Antiquities*, (revised and enlarged edition) London 1875.
- EAA* = *Enciclopedia dell’arte antica, classica e orientale*, Suppl. 2:2, Rome 1994.
- Emmerling 2011 = T.E. Emmerling, ‘“Öffentlich” und “privat”. Zur sozialen Funktion des römischen Wohnhauses’, in *Pompeji, Nola, Herculaneum*, 215–224.
- Ercolano* = M.R. Borriello, M.P. Guidobaldi & P.G. Guzzo (eds.), *Ercolano. Tre secoli di scoperte*, Milan 2008.
- Erhardt 1987 = W. Erhardt, *Stilgeschichtliche Untersuchungen an römischen Wandmalereien von der späten Republik bis zur Zeit Neros*, Mainz 1987.
- Eschebach 1984 = H. Eschebach, *Die Arzthäuser in Pompeji* (*Antike Welt*, Sondernummer 15), Mainz 1984.
- Eschebach 1993 = L. Eschebach, *Gebäudeverzeichnis und Stadtplan der antiken Stadt Pompeji*, Cologne – Weimar – Wien 1993.
- Esposito 2009 = D. Esposito, *Le officine pittoriche di IV stile a Pompei. Dinamiche produttive ed economico- sociale*, Rome 2009.
- Étienne 1992 = R. Étienne, *La vita quotidiana a Pompei*, Milan 1992 (*La vie quotidienne à Pompéi*, Paris 1966).
- Falkener 1852 = E. Falkener, ‘Report on a House at Pompeii, Excavated under personal superintendence in 1847’, in E. Falkener (ed.), *The Museum of Classical Antiquities: A Series of Papers on Ancient Art* 2:4, March 1852, “complete in one volume”, London 1855, 35–89.
- Farrar 2000 = L. Farrar, *Ancient Roman Gardens*, Stroud, Glos. 1998, rev. ed. 2000.
- Fejfer 2008 = J. Fejfer, *Roman Portraits in Context* (Image & Context 2), Berlin – New York 2008.
- Fioravanti – Caramiello 1999 = M. Fioravanti – R. Caramiello, ‘Il legno e la sua lavorazione’, in *Homo faber*, 85–86.
- Fiorelli 1875 = G. Fiorelli, *Descrizione di Pompei*, Naples 1875.
- Fotografi* = *Fotografi a Pompei nell’800 dalle collezioni del Museo Alinari* (Soprintendenza archeologica di Pompei, Le mostre 11), Florence 1990.
- Fowler 1989 = B.H. Fowler, *The Hellenistic Aesthetic*, Bristol 1989.

- Franklin 1980 = J.L. Franklin Jr., *Pompeii. The electoral programmata. Campaigns and politics, A.D. 71–79*, Rome 1980.
- Freccero 2005 = A. Freccero, *Pompeian plasters. Insula I 9 and Forum*, Rome 2005.
- Freccero 2011 = A. Freccero, 'IX 3, 5 Casa di Marco Lucrezio. Plasters and Phases', unpublished project report, 2011.
- Frese 2016 = S. Frese, 'Coroplastica', in F. Buranelli, M. Osanna & L. Toniolo (eds.), *Per Grazia Ricevuta. La devozione religiosa a Pompei antica e moderna*, Rome 2016, 54–61.
- Gaitzsch – Matthäus 1981 = W. Gaitzsch – H. Matthäus, 'Runcinae – römische Hobel', *BJ* 181 (1981) 205–247.
- Gallo 1994 = A. Gallo, *La casa di Lucio Elvio Severo a Pompei*, Naples 1994.
- García y García 2005 = L. García y García, *Pupils, Teachers and Schools in Pompeii. Childhood, Youth and Culture in the Roman Era*, Rome 2005.
- García y García 2006 = L. García y García, *Danni di guerra a Pompei. Una dolorosa vicenda quasi dimenticata* (Studi della Soprintendenza archeologica di Pompei 15), Rome 2006.
- Geist 1960 = H. Geist, *Pompeianische Wandinschriften*, Munich 1960².
- Giacobello 2008 = F. Giacobello, *Larari pompeiani. Iconografia e culto dei Lari in ambito domestico*, Milan 2008.
- Giumlia 1983 = A. Giumlia, *Die neuattischen Doppelhermen*, Diss. Vienna 1983.
- Graeven 1901 = H. Graeven, 'Die thönerne Sparbüchse im Altertum', *JDAI* 16 (1901) 160–189.
- Grandjouan 1961 = C. Grandjouan, *Terracottas and Plastic Lamps of the Roman Period* (The Athenian Agora 6), Princeton NJ 1961.
- Greek and Roman Antiquities* = William Smith (ed.), *A Dictionary of Greek and Roman Antiquities*, London 1859.
- Grimal 1943 = P. Grimal, *Les jardins romains à la fin de la République et aux deux premiers siècles de l'Empire. Essai sur le naturalisme romain* (BEFAR 155), Paris 1943.
- Grose 1989 = D.F. Grose, *The Toledo Museum of Art. Early Ancient Glass. Core-formed, Rod-formed and Cast Vessels and Objects from the Late Bronze Age to the Early Roman Empire, 1600 B.C. to A.D. 50*, New York 1989.
- Guggisberg 2015 = M.A. Guggisberg, 'La vaisselle à boire et la mise en scène du banquet aristocratique dans le monde étrusque et celtique', in A. Esposito (ed.), *Autour du "banquet". Modèles de consommation et usages sociaux*, Dijon 2015, 187–201.
- Guidobaldi 2008 = M.P. Guidobaldi, 'Le Terme Suburbane', in *Ercolano*, 66–69.
- Guzzo 2006 = P.G. Guzzo (ed.), *Argenti a Pompei*, Naples 2006.
- Guzzo – Scarano Ussani 2009 = P.G. Guzzo – V. Scarano Ussani, *Ex corpore lucrum facere. La prostituzione nell'antica Pompei*, Rome 2009.
- Hales 2003 = S. Hales, *The Roman House and Social Identity*, Cambridge 2003.
- Harden 1987 = D.B. Harden (ed.), *Glass of the Caesars*, Milan 1987.
- Harden – Price 1971 = D.B. Harden – J. Price, 'The glass', in B. Cunliffe (ed.), *Excavations at Fishbourne I: The Site*, Leeds 1971, 317–368.
- Hartswick 2018 = K.J. Hartswick, 'Sculpture in Ancient Roman Gardens', in W.F. Jashemski, K.L. Gleason, K.J. Hartswick & A.-A. Malek (eds.), *Gardens of the Roman Empire*, Cambridge 2018, 341–365.
- Heinemann 2011 = A. Heinemann, 'Ein dekorativer Gott? Bilder für Dionysos zwischen griechischer Votivpraxis und römischem Decorum', in R. Schlesier (ed.), *A Different God? Dionysos and Ancient Polytheism*, Berlin 2011.

- Heinrich 2002 = E. Heinrich, *Der Zweite Stil in pompejanischen Wohnhäusern*, Munich 2002.
- Heiska 2008 = N. Heiska, 'La documentazione topografica della casa di Marco Lucrezio', in *Domus pompeiana*, 174–181.
- Heller 1946 = J.L. Heller, 'Labyrinth or Troy Town?', *CJ* 42 (1946) 123–139.
- Heller 1961 = J.L. Heller, 'A Labyrinth from Pylos?', *AJA* 65, 1961, 57–62.
- Hilgers 1969 = W. Hilgers, *Lateinische Gefäßnamen*, Düsseldorf 1969.
- Hill 1981 = D.K. Hill, 'Some Sculpture from Roman Domestic Gardens', in Macdougall – Jashemski 1981, 81–94.
- Homo faber* = A.M. Ciarallo – E. De Carolis (eds.), *Homo faber. Natura, scienza e tecnologia nell'antica Pompei*, Milan 1999.
- Hundsatz 1987 = B. Hundsatz, *Das dionysische Schmuckrelief* (Tuduv-Studien, Reihe Archäologie 1), Munich 1987.
- Hunink 2011 = V. Hunink, *Glücklich ist dieser Ort! 1000 Graffiti aus Pompeji*, Stuttgart 2011.
- Hutchinson 1991 = V.J. Hutchinson, 'The cult of Dionysos/Bacchus in the Graeco-Roman world. New light from archaeological studies', *JRA* 4 (1991) 222–230.
- Häyhä 2008 = H. Häyhä, 'Ricomposizione dei frammenti di affresco', in *Domus Pompeiana*, 194–197.
- Iacopi 2008 = I. Iacopi, *La casa di Augusto. Le pitture*, Verona 2008.
- Isings 1957 = C. Isings, *Roman Glass from Dated Finds*, Groeningen 1957.
- Isler-Kerényi 2003 = C. Isler-Kerényi, 'Images grecques au banquet funéraire étrusque', *Pallas* 61 (2003) 39–53
- Jackson 1990 = R. Jackson, 'Roman Doctors and their Instruments: Recent Research into Ancient Practice', *JRA* 3 (1990) 5–27.
- Jackson 1994 = R. Jackson, 'Medical Instruments in the "Antiquarium" at Pompeii', in Bliquez 1994, 200–218.
- Jackson 1995 = R. Jackson, 'The Composition of Roman Medical *instrumentaria* as an Indicator of Medical Practice: A Provisional Assessment', in Ph.J. van der Eijk, H.F.J. Horstmanshoff & P.H. Schrijvers (eds.), *Ancient Medicine in its Socio-Cultural Context*, Amsterdam – Atlanta 1995, 189–319.
- Jackson 2003 = R. Jackson, 'The Medical Assemblage in the Domus "del chirurgo" at Rimini', *JRA* 16 (2003) 312–311.
- Jacobelli 2003 = L. Jacobelli, *Gladiatori a Pompei. Protagonisti, luoghi, immagini*, Rome 2003.
- Jahn 1854 = O. Jahn, 'Über ein Vasenbild, welches eine Töpferei vorstellt', *Berichte über die Verhandlungen der Königlich Sächsischen Gesellschaft der Wissenschaften zu Leipzig, Philologisch-Historische Klasse* 6 (1854) 27–48.
- Jahn 1857 = O. Jahn, Aufsatz über 'Auf einem Thongefäß befindliche lateinische Inschrift', *Berichte über die Verhandlungen der Königlich Sächsischen Gesellschaft der Wissenschaften zu Leipzig, Philologisch-Historische Klasse* 9 (1857) 191–205.
- Jashemski 1979 = W.F. Jashemski, *The Gardens of Pompeii, Herculaneum and the Villas Destroyed by Vesuvius*, New Rochelle NY 1979.
- Jashemski 1993 = W.F. Jashemski, *The Gardens of Pompeii, Herculaneum and the Villas Destroyed by Vesuvius* 2 (Appendices), New Rochelle NY 1993.
- Jashemski – Meyer 2002 = W.F. Jashemski – F.G. Meyer (eds.), *The Natural History of Pompeii*, Cambridge 2002.

- Joshel 2013 = S.R. Joshel, 'Geographies of Slave Containment and Movement', in M. George (ed.), *Roman Slavery and Roman Material Culture*, Toronto – Buffalo – London 2013, 99–128.
- Jucker 1956 = I. Jucker, *Der Gestus des Aposkopein. Ein Beitrag zur Gebärdensprache in der antiken Kunst*, Zürich 1956.
- Kaarto 2008 = P. Kaarto, 'Il modellando informatico tridimensionale dei resti', in *Domus Pompeiana*, 182–185.
- Kajanto 1965 = I. Kajanto, *The Latin Cognomina*, Helsinki 1965.
- Kapossy 1969 = B. Kapossy, *Brunnenfiguren der hellenistischen und römischen Zeit*, Zurich 1969.
- Kaufmann-Heinimann 1998 = A. Kaufmann-Heinimann, *Götter und Lararien aus Augusta Raurica. Herstellung, Fundzusammenhänge und sakrale Funktion figürlicher Bronzen in einer römischen Stadt* (Forschungen in Augst 26), Augst 1998.
- Kern 1983 = H. Kern, *Labyrinth. Erscheinungsformen und Deutungen. 5000 Jahre Gegenwart eines Urbilds*, Munich 1983².
- King 2002 = A. King, 'Mammals. Evidence from Wall Paintings, Sculpture, Mosaics, Faunal Remains, and Ancient Literary Sources', in Jashemski – Meyer 2002, 401–450.
- Knuutinen – Mannerheimo 2008 = U. Knuutinen – H. Mannerheimo, 'Gli studi sui pigmenti delle pitture parietali', in *Domus Pompeiana*, 186–193.
- Kolendo 1985 = J. Kolendo, 'Le attività agricole degli abitanti di Pompei e gli attrezzi agricoli ritrovati all'interno della città', *Opus* 4 (1985) 111–124.
- Komar 2014 = P. Komar, 'Greek Wines for the Roman Elite. In search of Eastern Luxuries on Western Tables', *Eos: Commentarii Societatis Philologiae Polonorum* 2 (2014) 227–244.
- Krenkel 1961 = W. Krenkel, *Pompejanische Inschriften*, Leipzig 1961.
- Krug 1993 = A. Krug, *Heilkunst und Heilkult. Medizin in der Antike*, Munich 1985, 1993².
- Kruschwitz – Campbell 2009 = P. Kruschwitz – V. Campbell, 'What the Pompeians saw: Representations of document types in Pompeian drawings and paintings (and their value for linguistic research)', *Arctos* 43 (2009) 57–84.
- Kuivalainen 2008 = I. Kuivalainen, 'Le sculture del giardino', in *Domus Pompeiana*, 127–137.
- Kunz 1981 = M. Kunz et al. (eds.), *3000 Jahre Glaskunst: Von der Antike bis zum Jugendstil*, Lucerne 1981.
- Künzl 2002 = E. Künzl, *Medizin in der Antike*, Stuttgart 2002.
- Laidlaw 1985 = A. Laidlaw, *The First Style in Pompeii: Painting and Architecture*, Rome 1985.
- Laidlaw 2007 = A. Laidlaw, 'Mining the Early Published Sources', in J.J. Dobbins – P.W. Foss (eds.), *The World of Pompeii*, London – New York 2007, 620–636.
- LaMotta – Schiffer 1999 = V.M. LaMotta – M.B. Schiffer, 'Formation Processes of House-floor Assemblages', in P. Allison (ed.), *The Archaeology of Household Activities*, London – New York 1999, 19–29.
- Langner 2001 = M. Langner, *Antike Graffitizeichnungen. Motive, Gestaltung und Bedeutung*, Wiesbaden 2001.
- Lapatin 2014 = K. Lapatin (ed.), *The Berthouville Silver Treasure and Roman Luxury* (The J. Paul Getty Museum publications), Los Angeles 2014.
- La pittura di un impero* = E. La Rocca, S. Ensoli, S. Tortorella & M. Papini (eds.), *Roma. La pittura di un impero*, Rome 2009.
- Levi 1926 = A. Levi, *Le terrecotte figurate del Museo Nazionale di Napoli*, Florence 1926. *Life and death* = P. Roberts (ed.), *Life and death in Pompeii and Herculaneum*, London 2013.
- LIMC = *Lexicon Iconographicum Mythologiae Classicae* 2, Zürich – Munich – Düsseldorf 1984.

- Lindsay 1960 = J. Lindsay, *The Writing on the Wall. An Account of Pompeii in its last Days*, London 1960.
- Ling 1991 = R. Ling, *Roman Painting*, Cambridge 1991.
- Ling 2005 = R. Ling – L. Ling, *The Insula of the Menander at Pompeii 2: the decorations*, Oxford 2005.
- Lippold 1909 = G. Lippold, 'Griechische Schilde', in *Münchener archäologische Studien dem Andenken Adolf Furtwänglers gewidmet*, Munich 1909, 399–504.
- Lippold 1921 = G. Lippold, 'Doppelseitiges Relief in Barcelona', *JDAI* 36 (1921) 33–44.
- Lissarrague 1990 = F. Lissarrague, 'The Sexual Life of Satyrs', in D.M. Halperin, J.J. Winkler & F.I. Zeitlin (eds.), *Before Sexuality: The Construction of Erotic Experience in the Ancient Greek World*, Princeton NJ 1990, 53–81.
- Lloyd-Morgan 1981 = G. Lloyd-Morgan, *The Mirrors. Description of the Collection in the Rijksmuseum G.M. Kam at Nijmegen*, Nijmegen 1981.
- Loar 2018 = M.P. Loar, 'Sexual Graffiti in the House of Marcus Lucretius in Pompeii (IX.3.5, 24)', *CW* 111 (2018) 405–431.
- Loeschke 1919 = S. Loeschke, *Lampen aus Vindonissa*, Zurich 1919.
- Lohmann 2018 = P. Lohmann, *Graffiti als Interaktionsform. Geritzte Inschriften in den Wohnhäusern Pompejis* (Materiale Textkulturen 16), Berlin – Boston 2018.
- LTUR = E.M. Steinby (ed.), *Lexicon Topographicum Urbis Romae* 4, Rome 1999.
- Lullies 1931 = R. Lullies, *Die Typen der griechischen Herme* (Königsberger kunstgeschichtliche Forschungen 3), Königsberg Pr. 1931.
- Macdougall – Jashemski 1981 = E.B. Macdougall – W.F. Jashemski (eds.), *Ancient Roman Gardens* (Dumbarton Oaks Colloquium on the History of Landscape Architecture 7, 1979), Washington DC 1981.
- MacKinnon 2008 = M. MacKinnon, 'I pranzi luculliani di Marco Lucrezio', in *Domus Pompeiana*, 147–148.
- Magaldi 1928 = E. Magaldi, 'Di Proculo, principe dei panettieri pompeiani, e studioso anche', *Nuova Cultura* 5 (1928) 49–63.
- Maguregui et al. 2010 = M. Maguregui, U. Knuutinen, K. Castro & J.M. Madariaga, 'Raman spectroscopy as a tool to diagnose the impact and conservation state of Pompeian second and fourth style wall paintings exposed to diverse environments (House of Marcus Lucretius)', *Journal of Raman Spectroscopy* 41:11 (2010) 1400–1409.
- Maiuri 1932 = A. Maiuri, *La casa del Menandro e il suo tesoro di argenteria*, Rome 1932.
- Maiuri 1942 = A. Maiuri, *L'ultima fase edilizia di Pompei* (Italia romana. Campania romana 2), Rome 1942.
- Mallon – Marichal – Perrat 1939 = J. Mallon, R. Marichal & Ch. Perrat, *L'écriture latine de la capitale romaine à la minuscule*, Paris 1939.
- Manning 1985 = W.H. Manning, *Catalogue of the Romano-British Iron Tools, Fittings and Weapons in the British Museum*, London 1985.
- Marmora pompeiana* = A. Carrella, L.A. D'Acunto, N. Insera & C. Serpe, *Marmora pompeiana nel Museo Archeologico Nazionale di Napoli. Gli arredi scultorei delle case pompeiane* (Studi della Soprintendenza archeologica di Pompei 26), Rome 2008.
- Maschere ornamentali = N. Savarese (ed.), 'Maschere ornamentali', in *In scaena. Il teatro di Roman antica*, Naples 2007, 131.

- Mastroroberto 1991 = M. Mastroroberto, 'La decorazione scultorea dei giardini' in *Cronache dal 79 d.C. Frammenti di vita quotidiana alle pendici del Vesuvio* (Soprintendenza archeologica di Pompei, Le mostre 12), s.l. 1991, 17–21.
- Mastroroberto 1992 = M. Mastroroberto, 'La scultura dei giardini', in *Domus – viridaria – horti picti*, 39–43.
- Mastroroberto 2003 = M. Mastroroberto, 'Gli arredi domestici', in G. Stefani (ed.), *Menander. La casa del Menandro di Pompei*, Milan 2003, 110–131.
- Mastroroberto 2011 = M. Mastroroberto, 'Table en marbre avec Silène et Dionysos enfant', in *Pompéi. Un art de vivre*, 191.
- Mau 1882 = A. Mau, *Geschichte der dekorativen Wandmalerei in Pompeji*, Berlin 1882.
- Mau 1908 = A. Mau, *Pompeji in Leben und Kunst*, (zweite verbesserte und vermehrte Auflage) Leipzig 1908.
- Maulucci Vivolo 1993 = F.P. Maulucci Vivolo, *Pompei. I graffiti figurati*, Foggia 1993.
- Mazzoleni 2004 = D. Mazzoleni, *Domus. Wall Painting in the Roman House*, Los Angeles 2004.
- MB = *Real Museo Borbonico* 1–16, Naples 1824–1857.
- Mercer 1929 = H.C. Mercer, *Ancient Carpenter's Tools Illustrated and Explained*, Doylestown PA 1929, repr. 2000, Mineola NY.
- Merker 2000 = G.S. Merker, *The Sanctuary of Demeter and Kore. Terracotta Figurines of the Classical, Hellenistic, and Roman Periods* (Corinth 18,4), Princeton NJ 2000.
- Meyer 2009 = E.A. Meyer, 'Writing Paraphernalia, Tablets, and Muses in Campanian Wall Painting', *AJA* 113 (2009) 569–597.
- Meyer 2010 = R. Meyer, 'The Conservation of the Frescoes from Boscoreale in the Metropolitan Museum', in B. Bergmann, S. De Caro, J. R. Mertens & R. Meyer, *Roman Frescoes from Boscoreale. The Villa of Publius Fannius Synistor in Reality and Virtual Reality*, New York 2010, 33–46.
- Michel 1980 = D. Michel, 'Pompejanische Gartenmalereien', in H.A. Cahn – E. Simon (eds.), *Tainia: Roland Hampe zum 70 Geburtstag am 2. Dezember 1978*, Mainz am Rhein 1980, 373–404.
- Milne 1909 = J.S. Milne, *Surgical Instruments in Greek and Roman Times*, Oxford 1909.
- Mimno 2011 = D. Mimno, 'Reconstructing Pompeian Households', in F. Cozman – A. Pfeffer (eds.), *UAI11 Proceedings of the Twenty-Seventh Conference on Uncertainty of Artificial Intelligence, Barcelona 2011*, Arlington VA 2011, 506–513.
- Minervini 1854 = G. Minervini, 'Casa di Marco Lucrezio', in Niccolini 1854, 1–22, pl. I–IX.
- Minervini 1855 = G. Minervini, 'Nuove osservazioni, e compimento della descrizione della casa di M. Lucrezio in Pompei', 'Casa di M. Lucrezio in Pompei', *BullArchNap*, N.S. 4 (1855) 52–56, 65–67, 81–87.
- Miniero 1987 = P. Miniero, 'Studio di un carro romano dalla villa c.d. di Arianna a Stabia', *MEFRA* 99 (1987) 171–209.
- Miniero 1991 = P. Miniero, 'I trasporti', in R. Cappelli (ed.), *Viae publicae romanae*, Rome 1991, 104–109.
- Mollard-Besques 1963 = S. Mollard-Besques, *Musée national du Louvre. Catalogue raisonné des figurines et reliefs en terre-cuite grecs et romains 2. Myrina*, Paris 1963.
- Mols 1999 = S. Mols, *Wooden Furniture in Herculaneum. Form, Technique and Function*, Amsterdam 1999.

- Mols – Moormann 1993–1994 = S.T.A.M. Mols – E.M. Moormann, 'Ex parvo crevit. Proposta per una lettura iconografica della tomba di Vestorius Priscus fuori Porta Vesuvio a Pompei', *RSP* 6 (1993–1994) 15–52.
- Monnier 1871 = M. Monnier, *The Wonders of Pompeii* (orig. *Pompéi et les Pompéiens* 1864), New York 1871.
- Monteix 2014 = 'Histoire politique des élites et histoire économique. L'exemple des Caii Iulii et des Marci Lucretii à Pompéi', in C. Apicella, M.-L. Haack & F. Lerouxel (eds.), *Les affaires de Monsieur Andreau. Économie et société du monde romain*, Bordeaux 2014, 259–271.
- Monteix 2018 = N. Monteix, 'Street façade society? Les réseaux sociaux à Pompéi au filtre de la propagande politique', *ArchClass* 69 (2018) 297–332.
- Moormann 1993 = E.M. Moormann, 'I vecchi ritrovamenti', in W.J.Th. Peters (ed.), *La casa di M. Lucretius Fronto a Pompei e le sue pitture*, Amsterdam 1993, 389–400.
- Moormann 2015 = E.M. Moormann, *Pompeii's Ashes, The Reception of the Cities Buried by Vesuvius in Literature, Music and Drama*, Boston – Berlin – Munich 2015.
- Morisco 2012 = M. Morisco, 'Gli inventari del Museo Archeologico Nazionale di Napoli', *RSP* 23 (2012) 103–108.
- Moss 1988 = C.F. Moss, *Roman Marble Tables*, Diss. Princeton NJ 1988.
- Mouritsen 1988 = H. Mouritsen, *Elections, magistrates and municipal élite. Studies in Pompeian epigraphy*, Rome 1988.
- Mulliez 2014 = M. Mulliez, *Le luxe de l'imitation. Les trompe-l'oeil de la fin de la République romaine, mémoire des artisans de la couleur* (Collection du Centre Jean Bérard 44), Naples 2014.
- Munsell Soil Color Charts = Munsell Soil Color Charts. Year 2000 revised washable edition.*
- Mustilli 1950 = D. Mustilli, 'Botteghe di scultori, marmorarii, bronzieri e caelatores in Pompei', in *Pompeiana. Raccolta di studi per il secondo centenario degli scavi di Pompei* (Biblioteca della Parola del passato 4), Naples 1950, 206–229.
- Neudecker 1988 = R. Neudecker, *Die Skulpturenausstattung römischer Villen in Italien* (Beiträge zur Erschließung hellenistischer und kaiserzeitlicher Skulptur und Architektur 9), Mainz am Rhein 1988.
- Neudecker 2015 = R. Neudecker, 'Gardens', in R. Rubina – J. Rüpke (eds.), *A Companion to the Archaeology of Religion in the Ancient World*, Oxford 2015, 220–234.
- Neuerburg 1965 = N. Neuerburg, *L'architettura delle fontane e dei ninfei nell'Italia antica* (Memorie dell'Accademia di archeologia, lettere e belle arti di Napoli 5), Naples 1965.
- Nevett 1997 = L. Nevett, 'Perceptions of Domestic Space in Roman Italy', in B. Rawson – P. Weaver (eds.), *The Roman Family in Italy: Status, Sentiment, Space*, Oxford 1997, 281–298.
- Nevett 2010 = L. Nevett, *Domestic Space in Classical Antiquity*, Cambridge 2010.
- Newby – Schut 1999 = M. Newby – D. Schut, *The Fascination of Ancient Glass. Dolf Schut Collection*, Lochem 1999.
- Niccolini 1854 = F. Niccolini – F. Niccolini, 'Casa di M. Lucrezio', *Le case ed i monumenti di Pompei disegnati e descritti* 1, Naples 1854.
- Nicolet 1967 = C. Nicolet, 'Tribuni militum a populo', *MEFRA* 79 (1967) 29–76.
- Nissinen 2009 = L. Nissinen, 'Cubicula diurna, nocturna. Revisiting Roman cubicula and Sleeping Arrangements', *Arctos* 43 (2009) 85–107.
- NSc = Notizie degli Scavi di Antichità*, Rome 1876–.
- Nuber 1972 = H.U. Nuber, 'Kanne und Griffschale. Ihr Gebrauch im täglichen Leben und die Beigabe in Gräbern der römischen Kaiserzeit', *BRGK* 53 (1972) 1–232.

- Nutrire l'impero* = C. Parisi Presicce – O. Rossini (eds.), *Nutrire l'impero. Storie di alimentazione da Roma a Pompei*, Rome 2015.
- Oettel 1991 = A. Oettel, *Bronzen aus Boscoreale in Berlin*, Berlin 1991.
- Opdenhoff 2011 = F. Opdenhoff, 'Der Haushalt im Haushalt – Das Verwalterhaus', in *Pompeji, Nola, Herculaneum*, 256–265.
- Overbeck 1856 = J. Overbeck, *Pompeji in seinen Gebäuden* (Alterthümern und Kunstwerken für Kunst- und Alterthumsfreunde), Leipzig 1856.
- Overbeck – Mau 1884 = J. Overbeck – A. Mau, *Pompeji in seinen Gebäuden, Alterthümern und Kunstwerken*, Leipzig 1884⁴.
- Oxé – Comfort – Kendrick 2000 = A. Oxé, H. Comfort & P.M. Kendrick, *Corpus vasorum Arretinorum. A catalogue of the signatures, shapes and chronology of Italian sigillata*, Bonn 2000.
- Pagano 2003a = M. Pagano, 'Utensili in ferro, bronzo e pietra', in G. Stefani (ed.), *Menander. La casa del Menandro di Pompei*, Milan 2003, 198–205.
- Pagano 2003b = M. Pagano, 'Fornix 12', in *Storie da un'eruzione*, 134–136.
- PAH* = G. Fiorelli (ed.), *Pompeianarum antiquitatum historia* I (1860), II (1862), Naples.
- Pailler 1982 = J.-M. Pailler, 'Les *oscilla* retrouvés', *MEFRA* 94:2 (1982) 743–822.
- Palmeri 2007 = P. Palmeri, 'La tradizione e l'uso del pane nel Mediterraneo. Spunti per un'indagine antropologica', *Narrare i gruppi. Etnografia dell'interazione quotidiana* 2, 2007, 1–24.
- Panofka 1847a = Th. Panofka, 'Scavi di Pompei', *Bull.Inst* 8 (1847) 129–137.
- Panofka 1847b = Th. Panofka, 'Neueste pompejanische Ausgrabungen', *Archäologische Zeitung* 5 (N. F. 1), (1847) 141–144.
- Pancaldi 1848 = C. Pancaldi, *Il magnifico Iaccheo pompeiano. Ossia sacrario dei misteri dionisiaci dell'anno 1847, s.l.* 1848.
- Parisi 2016 = V. Parisi, 'Le terrecotte figurate e l'uso rituale dei *signa fictilia* nelle aree sacre pubbliche della
- Pompei preromana. Elementi per una sintesi', in E. Lippolis – M. Osanna (eds.), *I pompeiani e i loro dei. Culti, rituali e funzioni sociali a Pompei* (Scienze dell'antichità 22.3), Rome 2016, 185–205.
- Pasqualini 2008 = A. Pasqualini, 'Mappa liturgica dei flamini minori di Roma', in M. Caldelli, G. Gregori & S. Orlandi (eds.), *Epigrafia 2006. Atti della XIVe Rencontre sur l'épigraphie in onore di Silvio Panciera con altri contributi di colleghi, allievi e collaboratori* (Tituli 9), Rome 2008, 437–452.
- Paunov 2015 = J.I. Paunov, 'A Portrait Glass Phalera from Novae Reconsidered', in A. Tomas (ed.), *Ad fines Imperii Romani. Studia Thaddaeo Sarnowski septuagenario ab amicis, collegis dedicata*, Warsaw 2015, 195–199.
- Pensabene – Sanzi Di Mino 1983 = P. Pensabene – M.R. Sanzi Di Mino, *Museo Nazionale Romano. Le Terrecotte* 3:1. *Antefisse*, Rome 1983.
- Perrin 2006 = Y. Perrin, 'Présence de Dionysos dans la fabrique de la Domus aurea de l'Esquilin', in A. Vigourt,
- X. Lorient, A. Bérenger-Badel & B. Klein (eds.), *Pouvoir et religion dans le monde romain, en hommage à Jean-Pierre Martin* (Passé Présent), Paris 2006, 129–146.
- Pesando 2012 = F. Pesando, 'I luoghi della schiavitù', in A. Giardina – F. Pesando (eds.), *Roma caput mundi: una città tra dominio e integrazione*, Rome 2012, 191–200.

- Peters 1993 = W.J.Th. Peters (ed.), *La casa di Marcus Lucretius Fronto a Pompei e le sue pitture*, Amsterdam 1993.
- Petrianni 2003 = A. Petrianni, *Il vasellame a matrice della prima età imperiale* (Collezione Gorga, Vetri I), Florence 2003.
- Pietilä-Castrén 2008 = L. Pietilä-Castrén, 'Le statuette di terracotta', in *Domus Pompeiana*, 138–145.
- Pirzio Biroli Stefanelli 1990 = L. Pirzio Biroli Stefanelli (ed.), *Il bronzo dei romani. Arredo e suppellettile*, Rome 1990.
- Pompeii AD 79* = J. Ward-Perkins – A. Claridge, *Pompeii AD 79* (Royal Academy of Arts, Piccadilly, London, 20 November 1976 – 27 February 1977), London 1978.
- Pompeii in cartolina* = A. Prisco – E. Manzi (eds.), *Pompeii in cartolina/Pompeii in postcard: Il paesaggio, il santuario e la mitica città ritrovata nelle antiche cartoline*, Cava de' Tirreni 2016.
- Pompeii. Un art de vivre* = S. De Caro, P. Nitti, V. Sampaolo & A. Varone (eds.), *Pompeii. Un art de vivre*, Paris 2011.
- Pompeii, Nola, Herculaneum* = H. Meller – J.-A. Dickmann (eds.), *Pompeii, Nola, Herculaneum. Katastrophen am Vesuv*, Munich 2011.
- PPM* = I. Baldassarre (ed.), *Pompeii. Pitture e Mosaici*, Rome 1990–2003.
- PPM Disegnatori* 1995 = G. Pugliese Carratelli – I. Baldassarre (eds.), *Pompeii pitture e mosaici. La documentazione nell'opera di disegnatori e pittori dei secoli XVIII e XIX*, Rome 1995.
- Price – Cottam 1998 = J. Price – S. Cottam, *Romano-British Glass Vessels. A Handbook* (CBA Practical Handbook in Archaeology 14), York 1998.
- Proto 2006 = F. Proto, 'Tabernae, officinae ed altri impianti a carattere commerciale della Regio I di Pompei: un campione di indagine socio-economica', *RSP17* (2006) 15–28.
- Quaranta 1847 = B.[ernardo] Q.[uaranta], 'Scavazioni di Pompei di marzo a tutto giugno 1847', *Annali Civili del Regno delle Due Sicilie* 43–45:89, Naples 1847, 71–75.
- Radnóti 1938 = A. Radnóti, *Bronzegefäße von Pannonien* (Dissertationes Pannonicae II/6), Budapest 1938.
- Raoul-Rochette 1852 = D. Raoul-Rochette, 'Notice des découvertes les plus récentes opérées dans le royaume de Naples et dans l'État romain, de 1847 à 1851', *JS* 1852, 65–80, 232–247, 296–304.
- RE* = *Paulys Realencyclopädie der classischen Altertumswissenschaft*, Stuttgart 1890–1980.
- Rediscovering* = L. Franchi dell'Orto – A. Varone (eds.), *Rediscovering Pompeii*, Rome 1990.
- Reinach 1906–1930 = S. Reinach, *Répertoire de la statuaire grecque et romaine* 1–6, (1–2 deuxième édition), Paris 1906–1930.
- Ridgway 1970 = B.S. Ridgway, 'Dolphins and Dolphin-Riders', *Archaeology* 23:2 (1970) 86–95.
- Riemenschneider 1986 = U. Riemenschneider, *Pompejanische Stuckgesimse des Dritten und Vierten Stils*, Frankfurt am Main – Bern – New York 1986.
- Riggsby 1997 = A. Riggsby, "Public" and "private" in Roman Culture. The Case of the Cubiculum', *JRA* 10 (1997) 36–56.
- Riha 1986 = E. Riha, *Römisches Toilettengerät und medizinische Instrumente aus August und Kaiserzeit*, (Forschungen in August 6), August 1986.
- Roberts 2013 = P. Roberts, *Life and Death in Pompeii and Herculaneum*, London 2013.
- Robinson 1924 = D.M. Robinson 'Some Roman Terracotta Savings Banks', *AJA* 28 (1924) 239–250.

- Robinson 2002 = M.A. Robinson, 'Domestic burnt offerings and sacrifices at Roman and pre-Roman Pompeii', *Vegetation History and Archaeobotany* 11 (2002) 93–99.
- Robinson 2005 = M.A. Robinson, 'Fosse, piccole fosse e peristili a Pompei', in P.G. Guzzo – M.P. Guidobaldi (eds.), *Nuove ricerche archeologiche a Pompei ed Ercolano*, Naples 2005, 109–119.
- Rocco 2017 = A. Rocco, *Catalogo della suppellettile bronzea di uso domestico del museo nazionale di Napoli*, Nella Castiglione Morelli (ed.), Naples 2017.
- von Rohden 1880 = H. von Rohden, *Die antiken Terracotten 1. Die Terracotten von Pompeji* 1, Stuttgart 1880.
- Romana pictura* = A. Donati (ed.), *Romana pictura. La pittura romana dalle origini all'età bizantina*, Naples 1998.
- Rosso pompeiano* = M.L. Nava, R. Paris & R. Friggeri (eds.), *Rosso pompeiano. La decorazione pittorica nelle collezioni del Museo di Napoli e a Pompei*, Milan 2007.
- Ruesch 1908 = A. Ruesch, *Guida illustrata del Museo nazionale di Napoli*, Naples 1908.
- Räsänen – Wassholm 2008 = A. Räsänen – H. Wassholm, 'Ricostruzione delle pitture parietali del triclinio', in *Domus Pompeiana*, 198–203.
- Salazar 1913 = A. Salazar, 'El modio de Ponte Puñide', *Boletín de la Real Academia Gallega* 8 (1913).
- von Saldern 1985 = A. von Saldern, 'Römische Hochschliffgläser', *Jahrbuch des Museums für Kunst und Gewerbe Hamburg* 4 (1985) 27–42.
- von Saldern 1991 = A. von Saldern, 'Roman cut glass with decoration cut in high-relief', in M. Newby – K. Painter (eds.), M. Newby – K. Painter (eds.), *Roman Glass. Two Centuries of Art and Invention*, London, 1991, 111–121.
- Sampaolo 2005 = V. Sampaolo, 'Strumenti inventariati per il riordino della collezione degli affreschi del Museo archeologico nazionale di Napoli', *Ocnus* 13 (2005) 283–290.
- Sangue e arena* = A. La Regina (ed.), *Sangue e arena*, Milan 2001.
- Sarullo 2008 = G. Sarullo, 'Labirinti a Pompei: a proposito di CIL IV 2331', *Oebalus* 3 (2008) 203–223.
- Saward 2003 = J. Saward, *Labyrinths and Mazes*, London 2003.
- Scatozza Höricht 1986 = L.A. Scatozza Höricht, *I vetri romani di Ercolano* (Soprintendenza archeologica di Pompei, Cataloghi 1), Rome 1986.
- Scatozza Höricht 2012 = L.A. Scatozza Höricht, *L'instrumentum vitreum di Pompei*, Rome 2012.
- Schefold 1957 = K. Schefold, *Die Wände Pompejis. Topographisches Verzeichnis der Bildmotive*, Berlin 1957.
- Schiffer 1996 = M.B. Schiffer, *Formation Processes and the Archaeological Record*, Salt Lake City 1996.
- Schürmann 1989 = W. Schürmann, *Katalog der antiken Terrakotten im Badischen Landesmuseum Karlsruhe*, (Studies in Mediterranean Archaeology 84), Gothenburg 1989.
- Sequence and Space* = S.E. Bon – R. Jones (eds.), *Sequence and Space in Pompeii*, Oxford 1997.
- Sergejenko 1953 = M.J. Sergejenko, *Pompeji*, Leipzig 1953.
- Sigges 2001 = B. Sigges, *Vita cognita. Die Ausstattung pompejanischer Wohnhäuser mit Gefäßen und Geräten – untersucht an ausgewählten Beispielen*, Diss. Cologne 2001.
- Simelius 2015 = S. Simelius, 'Activities in Pompeii's Private Peristyles. The Place of the Peristyle in the Public/Private Dichotomy', in L. Nissin – K. Tuori (eds.), *Public and Private in the Roman House and Society (JRA Suppl. 102)*, Portsmouth RI 2015, 119–132.
- Siviero 1954 = R. Siviero, *Gli ori e le ambre del museo nazionale di Napoli*, Florence 1954.

- Sodo 2003 = A.M. Sodo, 'Il cisium birotus', in G. Stefani (ed.), *Menander. La casa del Menandro di Pompei*, Milan 2003, 206–209.
- Solin 2003 = H. Solin, *Die griechischen Personennamen in Rom. Ein Namenbuch* 1–3, Berlin – New York 2003².
- Spinazzola 1928 = V. Spinazzola, *Le arti decorativi in Pompei e nel Museo Nazionale di Napoli*, Naples 1928.
- Stefani 2002 = G. Stefani (ed.), *Uomo e ambiente nel territorio vesuviano*, Pompei 2002.
- Stefani 2003 = G. Stefani, 'La casa del Menandro (I, 10, 4)', in *Storie da un'eruzione*, 355–367.
- Stefanidou-Tiveriou 1997 = Th. Stefanidou-Tiveriou, 'Cat. 102: Table support with Eros', in G. Despini, Th. Stefanidou-Tiveriou & E.M. Voutiras (eds.), *Catalogue of Sculpture in the Archaeological Museum of Thessaloniki* 1, Thessaloniki 1997, 132–133.
- Stefanile 2016 = M. Stefanile, 'Ceius Secundus, Helvius Sabinus, Suedius Clemens: alcune novità epigrafiche dalla schedatura dei *tituli picti* pompeiani per EDR', *Vesuviana* 8 (2016) 83–102.
- Stefanile 2018 = M. Stefanile, 'La schedatura dei *tituli picti* pompeiani per EDR: novità sulla cronologia di Suedio Clemente e di alcuni candidati', in S. Antolini – S.M. Marengo – G. Paci (eds.), *Colonie e municipi nell'era digitale. Documentazione epigrafica per la conoscenza delle città antiche* (Atti del Convegno di studi Macerata, 10-12 dicembre 2015), *Ichnia* 14 (2018) 601–613.
- Storie da un'eruzione* = P.G. Guzzo (ed.), *Storie da un'eruzione. Pompei, Ercolano, Oplontis*, Milan 2003.
- Strocka 1975 = V.M. Strocka, 'Pompejanische Nebenzimmer', in B. Andreae – H. Kyrieleis (eds.), *Neue Forschungen in Pompeji und den anderen vom Vesuviusausbruch 79 n. Chr. verschütteten Städten*, Essen 1975, 101–114.
- Strocka 1991 = V.M. Strocka, *Casa del Labirinto (VI 11, 8-10)*, (Häuser in Pompeji 4), Munich 1991.
- Suolahti 1955 = J. Suolahti, *The Junior Officers of the Roman Army in the Republican Period*, Helsinki 1955.
- Tammisto – Kuivalainen 2008 = A. Tammisto – I. Kuivalainen, 'Pitture e pavimenti della Casa di M. Lucrezio', in *Domus Pompeiana*, 72–103.
- Tammisto – Wassholm 2016 = 'DOMVS POMPEIANA MARCI LVCRETII REDIVIVA. Reconstructing the House of Marcus Lucretius in Helsinki', in S. Hales & A.-M. Leander Touati (eds.), *Returns to Pompeii. Interior space and decoration documented and revived. 18th-20th century* (Skrifter utgivna av Svenska Institutet i Rom, 4^o, 62), Stockholm 2016, 245–271.
- Tanagra* = V. Jeammet (ed.), *Tanagra. Mythe et archéologie*, Paris 2003.
- Tarbell 1909 = F.B. Tarbell – G.A. Dorsey, *Catalogue of Bronzes, Etc., in Field Museum of Natural History, Reproduced from Originals in the National Museum of Naples* (Field Museum of Natural History, Publication 130, Anthropological Series 7:3), Chicago 1909.
- Tassinari 1993 = S. Tassinari, *Il vasellame bronzeo di Pompei*, Rome 1993.
- Tassinari 1996 = S. Tassinari, 'Bouillir, mijoter et cuire, porter et mesurer: le rôle de la vaisselle métallique dans les cuisines de Pompei', in M. Bats (ed.), *Les céramiques communes de Campanie et de Narbonnaise (Ier s. av. J.-C. – IIe s. ap. J.-C.)*. *La vaisselle de cuisine et de table*, Naples 1996.
- Taylor 2005 = R. Taylor, 'Roman Oscilla. An Assessment', *Anthropology and aesthetics* 48 (2005) 83–105.
- ThesCRA* = *Thesaurus Cultus et Rituum Antiquorum* 4 (2004), 5 (2005), Los Angeles.

- Thompson 1968 = F.H. Thompson, 'The Zoomorphic Pelta in Romano-British Art', *Antiquaries Journal* 48 (1968) 47–58.
- Tran Tam Tinh 1975 = V. Tran Tam Tinh, 'Les problèmes du culte de Cybèle et d'Attis à Pompei', in B. Andreae – H. Kyrieleis (eds.), *Neue in Pompeji und den anderen vom Vesuvausbruch 79 n. Chr. verschütteten Städten*, Recklinghausen 1975, 279–290.
- Trillmich 2007 = W. Trillmich, 'Typologie der Bildnisse der Iulia Agrippina', in M. Moltesen – A.M. Nielsen (eds.), *Agrippina Minor. Life and Afterlife. Liv og eftermæle* (Meddelelser fra Ny Carlsberg Glyptotek, Ny serie 9), Copenhagen 2007, 45–65.
- Turcan 1958 = R. Turcan, 'Dionysos dimorphos. Une illustration de la théologie de Bacchus dans l'art funéraire', *MEFRA* 70 (1958) 243–293.
- Turcan 2003 = R. Turcan, *Liturgies de l'initiation bacchique à l'époque romaine (Liber). Documentation littéraire, inscrite et figurée* (Memoires de L'Académie des Inscriptions et Belles-lettres 27), Paris 2003.
- Ulrich 2008 = R.B. Ulrich, *Roman Woodworking*, New Haven 2008.
- Valenza Mele 1981 = N. Valenza Mele, *Catalogo delle lucerne in bronzo. Museo archeologico nazionale di Napoli*, Rome 1981.
- Van Andringa 2009 = W. Van Andringa, *Quotidien des dieux et des hommes. La vie religieuse dans les cités du Vésuve à l'époque romaine* (BEFAR 337), Rome 2009.
- Varone 1995 = A. Varone, 'Più terremoti a Pompei? I nuovi dati degli scavi di via dell'Abbondanza', in T. Frölich – L. Jacobelli (eds.), *Archäologie und Seismologie* (Atti del Convegno Boscoreale 26-27 novembre 1993), Munich 1995, 29–35.
- Varone 2000 = A. Varone, *Pompei. I misteri di una città sepolta. Storia e segreti di un luogo in cui la vita si è fermata duemila anni fa*, Rome 2000.
- Varone 2005 = A. Varone, 'Convivere con i terremoti. La travagliata ricostruzione di Pompei dopo il terremoto del 62 d.C. alla luce delle nuove scoperte', in S. Mols – E.M. Moormann (eds.), *Omni pede stare. Saggi architettonici e circumvesuviani in memoriam J.A.K.E. de Waele*, Naples 2005, 315–323.
- Varone 2010 = A. Varone, 'Vini e mescite in area vesuviana. A proposito del bere a Pompei', in G. Di Pasquale (ed.), *Vinum nostrum. Arte, scienza e miti del vino nelle civiltà del mediterraneo antico*, Florence 2010, 216–227.
- Varone 2012 = A. Varone, *Titulorum graphio exaratorum qui in C.I.L. vol. IV collecti sunt imagines*, Rome 2012.
- Varone 2015 = A. Varone, 'Indagine su un cittadino al di sopra di ogni sospetto: Giulio Polibio', in V. Castiglione Morelli, E. De Carolis & C.R. Salerno (eds.), *Caio Giulio Polibio. Storie di un cittadino pompeiano*, Dragoni (CE) 2015, 95–116.
- Varone – Stefani 2009 = A. Varone – G. Stefani, *Titulorum pictorum Pompeianorum qui in CIL vol. IV collecti sunt imagines* (Studi della Soprintendenza archeologica di Pompei 29), Rome 2009.
- Vermaseren 1966 = M.J. Vermaseren, *The Legend of Attis in Greek and Roman Art*, Leiden 1966.
- Vermaseren 1977 = M.J. Vermaseren, *Cybele and Attis. The Myth and the Cult*, London 1977.
- Vierneisel-Schlörb 1997 = B. Vierneisel-Schlörb, *Die figürlichen Terrakotten I. Spätmykenisch bis späthellenistisch* (Kerameikos. Ergebnisse der Ausgrabungen 15), Munich 1997.
- Viitanen 2008 = E.-M. Viitanen, 'Studi archeologici a Pompei', in *Domus Pompeiana*, 165–173.
- Viitanen – Andrews 2008 = E.-M. Viitanen – J. Andrews, 'Storia edilizia e architettura della casa di Marco Lucrezio', in *Domus Pompeiana*, 51–71.

- Vulpes 1847 = B. Vulpes, *Illustrazione di tutti gli strumenti chirurgici scavati in Ercolano e in Pompei e che ora conservansi nel R. Museo Borbonico di Napoli, Naples 1847.*
- Väänänen 1966 = V. Väänänen, *Le latin vulgaire des inscriptions pompéiennes* (diss. Helsinki 1937), Berlin 1966³.
- Wallace 2005 = R.E. Wallace, *An Introduction to Wall Inscriptions from Pompeii and Herculaneum*, Wauconda IL 2005.
- Wallace-Hadrill 1988 = A. Wallace-Hadrill, 'The Social Structure of the Roman House', *PBSR* 56 (1988) 43–97.
- Wallace-Hadrill 1994 = A. Wallace-Hadrill, *Houses and Society in Pompeii and Herculaneum*, Princeton NJ 1994.
- Watson 2002 = G.E. Watson, 'Birds: Evidence from Wall Paintings, Mosaics, Sculpture, Skeletal Remains, and Ancient Authors', in Jashemski – Meyer 2002, 357–400.
- Webster 1995 = T.B.L. Webster, *Monuments Illustrating New Comedy* 1 (3rd edition revised and enlarged by J.R. Green and A. Seeberg), London 1995.
- Weeber 1996 = K.-W. Weeber, *Decius war hier. Das Beste aus der römischen Graffiti-Szene*, Zurich – Düsseldorf 1996.
- White 1967 = K.D. White, *Agricultural Implements in the Roman World*, Cambridge 1967.
- White 1975 = K.D. White, *Farm Equipment of the Roman World*, Cambridge 1975.
- Williams 1984 = E.R. Williams, *The Archaeological Collection of Johns Hopkins University*, Baltimore 1984.
- Wilson 2008 = A.I. Wilson, 'Large-scale Manufacturing, Standardization, and Trade', in J.P. Oleson (ed.), *The Oxford Handbook of Engineering in the Classical World*, Oxford 2008, 393–417.
- Leach 1997 = E. W. Leach, 'Oecus on Ibycus: The Vocabulary of the Roman House', in *Sequence and Space*, 50–72.
- Winter 1903 = F. Winter, *Die antiken Terrakotten* 3:2. *Die Typen der figürlichen Terrakotten* 2, Berlin – Stuttgart 1903.
- Wittmack 1903 = M.C.L. Wittmack, 'Die in Pompeji gefundenen pflanzlichen Reste', *Botanische Jahrbücher* 33, Beiblatt 73 (1903) 38–63.
- Wrede 1986 = H. Wrede, *Die antike Herme* (Trierer Beiträge zur Altertumskunde 1, 1985), Mainz am Rhein 1986.
- Ynnilä 2011 = H. Ynnilä, 'Meaningful Insula. Bridging the Gap between Large and Small Scale Studies of Urban Living Conditions', in D. Mladenovich – B. Russel (eds.), *TRAC 2010: Proceedings of the 20th Theoretical Roman Archaeology Conference*, Oxford 2011, 47–58.
- Ynnilä 2013a = H. Ynnilä, 'Crisis or Not? Living conditions in Pompeii in AD 79 – Insula IX.3 as a Case Study', in E.M. van der Wilt – J. Martínez Jiménez (eds.), *Tough Times: The Archaeology of Crisis and Recovery. Proceedings of the Graduate Archaeology at Oxford conferences in 2010 and 2011* (BAR International Series 2478), Oxford 2013, 67–76.
- Ynnilä 2013b = H. Ynnilä, 'Understanding Neighbourhood Relations through Shared Structures: Reappraising the Value of Insula-Based Studies', in A. Bokern – M. Bolder-Boos – S. Krmnicek – D. Maschek – S. Page (eds.), *TRAC 2012: Proceedings of the Twenty-Second Theoretical Roman Archaeology Conference, Frankfurt 2012*, Oxford 2013, 81–90.
- Zimmer 1982 = G. Zimmer, *Römische Berufsdarstellungen* (Archäologische Forschungen 12), Berlin 1982.
- Ziviello 1986 = C. Ziviello, 'I vetri', in *Collezioni Napoli*, 218–228.

Participants and Associates of the EPUH Project

Members of **EPUH** participating in the nine field campaigns in 2002–12: Sanna Aho (6), Ria Berg (8), Margherita Carucci (1), Paavo Castrén (5), Gianluca De Martino (6), Zbigniew T. Fiema (4), Marttiina Fränti-Pitkäranta (1), Ville Hakanen (3), Juha Heikkinen (2), Nina Heiska (5), Maija Holappa (9), Kai Juntunen (4), Anu Koponen (1), Ilkka Kuivalainen (9), Lotta Laiho-Oliviero (3), Jaakko Latikka (3), Otso Manninen (1), Kirsi Murros (9), Matti Mustonen (2), Laura Nissin (9), Daniel Pearson (1), Reija Penttinen (1), Leena Pietilä-Castrén (1), Maija Pohjanpalo (1), Essi Ruuskanen (2), Samuli Simelius (2), Antero Tammisto (9), Laura Tervonen (4), Tiina Tuukkanen (8), Eeva Vakkari (1), Katja Varakas (1), Eeva-Maria Viitanen (9), Anna Ylitalo (2), Heini Ynnilä (7).

Members of **EVTEK** (since 2008 Metropolia University of Applied Sciences) participating in four field campaigns in 2004-07 responsible for 3D modelling and pigment and plaster studies: Jukka Alander (1), Heidi Happonen (1), Noora Hirvonen (1), Tero Huttunen (1), Heikki Häyhä, (2), Pasi Kaarto, (3), Ulla Knuutinen (1), Pekka Kytölä (1), Hanne Mannerheim (2), Antti Markkula (1), Heli Pitkänen (1), Vesa Putkonen (3), Oskari Raunio (1), Mika Seppälä (1), Laura Vornanen (1), Helena Wassholm (1).

Osteological studies in field in 2007: Michael McKinnon (University of Winnipeg) & Elan Love.

Seven educational institutions and numerous individual collaborators participating in the making of the **Domus Pompeiana exhibition** in 2008 at the Amos Anderson Art Museum acknowledged in the exhibition catalogue *Domus Pompeiana – Una casa a Pompei* (2008).

Members of the research team of analytical chemistry **Analytica Pompeiana Universitatis Vasconicae** directed by Prof. Juan Manuel Madariaga (University of the Basque Country), pigment and plaster analyses of wall-paintings in 2010-11: Kepa Castro, Anastasia Giakoumaki, Ulla Knuutinen (Metropolia University of Applied Sciences), Maite Maguregui, Irantzu Martinez Arkarazo.

Pigment and plaster analyses of wall-paintings in 2011: Agneta Freccero (the Swedish Pompeii Project).

Members of the **Pompeian Aerial Survey Project** directed by James Andrews & Peter Rose, drone survey & 3D documentation by LE34 in 2012: Claus Bloch Houmann, Niels-Peter Granzow Busch, Johannes Kristensen, Troels Seerup Nielsson.

EPUH is grateful for the collaboration with the Museo archeologico Nazionale di Napoli, Soprintendenza archeologica di Pompeii, as well as with numerous Italian and international research teams active in the field in 2002–12, particularly the Pompei Progetto Regio VI directed by Filippo Coarelli & Fabrizio Pesando, the Swedish Pompeii Project directed by Anne-Marie Leander Touati, and the Pistrina Project directed by Nicolas Monteix.

Commentationes Humanarum Litterarum

- Vol. 90 (1990)
Solin, Heikki: Namenpaare. Eine Studie zur römischen Namengebung. 1990. 92 p.
- Vol. 91 (1990)
Roman Eastern Policy and Other Studies in Roman History, edited by Heikki Solin and Mika Kajava. 1990. 174 p.
- Vol. 93 (1991)
Bruun, Christer: The Water Supply of Ancient Rome. A Study of Roman Imperial Administration. 1991. 468 p.
- Vol. 94 (1991)
Koskenniemi, Erkki: Der philostratische Apollonios. 1991. 101 p.
- Vol. 95 (1992)
Löfstedt, Leena (ed.): Gratiani Decretum. La traduction en ancien français du Décret de Gratien. Edition critique. Vol I: Distinctiones. 1992. 213 p.
- Vol. 96 (1991)
Forsén, Björn: Lex Licinia Sextia de modo agrorum – fiction or reality? 1991. 88 p.
- Vol. 97 (1992)
Salomies, Olli: Adoptive and Polyonymous Nomenclature in the Roman Empire. 1992. 179 p.
- Vol. 99 (1993)
Löfstedt, Leena (ed.): Gratiani Decretum. La traduction en ancien français du Décret de Gratien. Edition critique. Vol II: Causae 1–14. 1993. 276 p.
- Vol. 102 (1994)
Leiwo, Martti: Neapolitana. A Study of Population and Language in Graeco-Roman Naples. 1994. 232 p.
- Vol. 103 (1995)
Chydenius, Johan: The Spirituality of Fénelon in his Latin Writings 1700-1712. 1995. 60 p.
- Vol. 104 (1995)
Acta colloquii epigraphici Latini Helsingiae 3.–6. sept. 1991 habiti, ediderunt Heikki Solin, Olli Salomies, Uta-Maria Liertz. 1995. 425 p.
- Vol. 105 (1996)
Löfstedt, Leena (ed.): Gratiani Decretum. La traduction en ancien français du Décret de Gratien. Edition critique. Vol III: Causae 15–29. 1996. 275 p.
- Vol. 108 (1996)
Mehtonen, Päivi: Old Concepts and New Poetics. Historia, Argumentum, and Fabula in the Twelfth- and Early Thirteenth-Century Latin Poetics of Fiction. 1996. 173 p.
- Vol. 109 (1996)
Kuisma, Oiva: Proclus' Defence of Homer. 1996. 157 p.
- Vol. 110 (1997)
Löfstedt, Leena (ed.): Gratiani Decretum. La traduction en ancien français du Décret de Gratien. Edition critique. Vol IV: Causae 30–36 et De Consecratione. 1997. 224 p.
- Vol. 111 (1998)
Lampela, Anssi: Rome and the Ptolemies of Egypt. The Development of their Political Relations 273–80 B.C. 1998. 301 p.
- Vol. 112 (1998)
Nummenmaa, Tapio: Divine Motions and Human Emotions in the Philebus and in the Laws. Plato's Theory of Physic Powers. 1998. 151 p.
- Vol. 113 (1999)
Thesleff, Holger: Studies in Plato's Two-Level Model. 1999. 143 p.
- Vol. 114 (1999)
Dimitropoulos, Panagiotis: Untersuchungen zum finalen Genetiv des substantivierten Infinitivs bei Thukydides. 1999. 117 p.
- Vol. 115 (2000)
Heinonen, Sirkka: Prometheus Revisited. Human Interaction with Nature through Technology in Seneca, 2000. 232 p.
- Vol. 116 (2000)
Lehtonen, Tuomas M. S. & Mehtonen, Päivi (eds.): Historia. The Concept and Genres in the Middle Ages. 2000. 142 p.

- Vol. 117 (2001)
Löfstedt, Leena (ed.): Gratiani Decretum. La traduction en ancien français du Décret de Gratien. Edition critique. Vol V: Observations et explications. 2001. 482 p.
- Vol. 118 (2002)
Kivistö, Sari: Creating Anti-eloquence. Epistolae obscurorum virorum and the Humanist Polemics on Style. 2002. 256 p.
- Vol. 119 (2002)
Salmenkivi, Erja: Cartonnage Papyri in Context. New Ptolemaic Documents from Abū Sir al Malaq. 2002. 182 p., 20 plates.
- Vol. 120 (2003)
Kuisma, Oiva: Art or Experience. A Study on Plotinus' Aesthetics. 2003. 207 p.
- Vol. 121 (2004)
Korhonen, Kalle: Le iscrizioni del Museo civico di Catania. 2004. 418 p.
- Vol. 122 1–2 (2007)
Proceedings of the 24th International Congress of Papyrology. Helsinki, 1–7 August, 2004, edited by Jaakko Frösén, Tiina Puroila and Erja Salmenkivi. 2007. 1075 p., plates.
- Vol. 123 (2007)
Steinby, Christa: The Roman Republican Navy. 2007. 236 p.
- Vol. 124 (2009)
Halla-aho, Hilla: The non-literary Latin letters. A study of their syntax and pragmatics. 2009. 190 p.
- Vol. 125 (2008)
The Konikovo Gospel (Bibl. Patr. Alex. 268), edited by Jouko Lindstedt, Ljudmil Spasov and Juhani Nuorluoto. 2008. 439 p., 82 plates.
- Vol. 126 (2009)
Sipilä, Joonas: The Reorganisation of Provincial Territories in Light of the Imperial Decision-making Process. Later Roman Arabia and Tres Palaestinae as Case Studies. 2009. 328 p.
- Vol. 127 (2010)
Saastamoinen, Ari: The Phraseology of Latin Building Inscriptions in Roman North-Africa. 2010. 646 p.
- Vol. 128 (2011)
Building Roma Aeterna. Current Research on Roman Mortar and Concrete. Proceedings of the conference, March 27–29, 2008. Editors Åsa Ringbom and Robert L. Hohlfelder, assistant editors Pia Sjöberg and Pia Sonck-Koota. 2011. 260 p.
- Vol. 129 (2011)
Eikonopoiia. Digital Imaging of Ancient Textual Heritage. Proceedings of the international conference Helsinki, 28–29, November, 2010, edited by Vesa Vahtikari, Mika Hakkarainen, Antti Nurminen. 2011. 267 p.
- Vol. 130 (2013)
Maurizi, Luca: Il cursus honorum senatorio da Augusto a Traiano. Sviluppo formali e stilistici nell'epigrafia latina e greca. 2013. 324 p.
- Vol. 131 (2014)
Papyri Turkuenses (P. Turku). Die Papyri im Besitz der Universitätsbibliothek Turku herausgegeben von Heikki Koskenniemi unter Mitwirkung von Erkki Koskenniemi und Johannes Koskenniemi. 2014. 135 p., Tafeln.
- Vol. 132 (2015)
Second Sailing: Alternative Perspectives on Plato. Edited by Debra Nails and Harold Tarrant in Collaboration with Mika Kajava and Eero Salmenkivi. 2015. 366 p.
- Vol. 133 (2016)
Korkiakangas, Timo: Subject Case in the Latin of Tuscan Charters of the 8th and 9th Centuries. 2016. 276 p.
- Vol. 134 (2018)
Kivistö, Sari: *Lucubrations Neolatinae*. Readings of Neo-Latin Dissertations and Satires. 2018. 244 p.
- Vol. 135 (2018)
Buchholz, Matias: Römisches Recht auf Griechisch. Prolegomena zu einer linguistischen Untersuchung der Zusammensetzung und Semantik des byzantinischen prozessrechtlichen Wortschatzes. 2018. 236 p.

